



Secondary Windows System

Introduction

The Monarch Secondary Window System comprises of all sections and associated hardware to enable the following types of window to be constructed.

- : HORIZONTAL SLIDING (2,3 AND 4 PANE) - with skids or roller assemblies.
- : VERTICAL SLIDING - with balances.
- : VERTICAL SLIDING - with spring retaining catches.
- : LIFTOUT
- : HINGED.

The recommended type of secondary window outer frame is designed to provide a CONCEALED FIX method. The secondary outer frame is secured to the existing window frame using screws-fixed through a recessed channel in the section. The securing screws are concealed by using a “clip in” aluminium or PVC cover trim.

All calculations for the wood fix system assume the recommended wood profile is being used. If this is not so, adjustments will have to be made to the calculations.

Important Notes

1. All configurations of secondary windows are as viewed from INSIDE and not outside, as with all other MONARCH products.
2. All dimensions are in millimetres unless otherwise stated.
3. 'W' is the overall width of the outer frame.
'H' is the overall height of the outer frame.
These sizes will include the recommended wood profiles when adopting the 'Wood Fix' method.
4. All mitre cut component length sizes relate to the tonger (point to point) dimension.

Sapa's policy is one of continual system development and we reserve the right to incorporate design improvements and changes. Every effort is made to ensure that all details are correct at time of publication. However, it is the responsibility of the customer to check the accuracy of the relevant facts and information before entering into any contract or other commitment. Up to date information is freely available from the Sapa Building Systems Webshop.
All Products and systems which Sapa supply are supplied subject to Sapa's standard Terms and Conditions of Sale current from time to time.

CONTENTS

1. GENERAL GUIDANCE NOTES

2. GLAZING INSTRUCTIONS

3. TOOLING AND EQUIPMENT REQUIREMENTS

4. HORIZONTAL SLIDING WINDOWS

5. VERTICAL SLIDING WINDOWS WITH BALANCES

**6. VERTICAL SLIDING WINDOWS WITH SPRING
RETAINING CATCHES**

7. LIFT OUT WINDOWS

8. HINGED WINDOWS

9. INSTALLATION INSTRUCTIONS

NOTE: Below is a dimensioned sketch showing the recommended wood profile use on the woodfix system.
To enable the use of the drill jigs supplied with the system it is essential that the wood profile below is used.

SECONDARY WINDOWS
SURROUND FOR 'WOOD FIX' SYSTEM

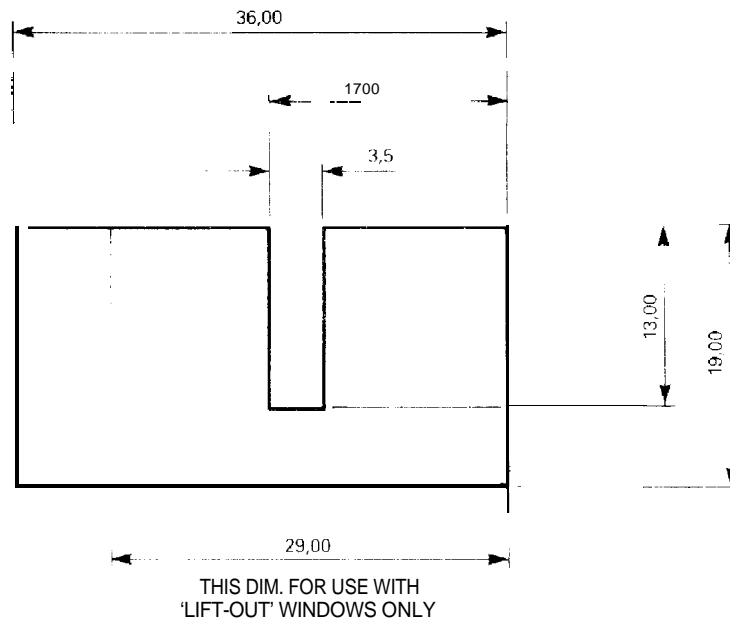

1. GENERAL GUIDANCE NOTES

- A. De-burr all saw cuts, paying particular attention to the areas around the screw ports. This will ensure a flush fitting frame.
- B. On assembly of the outer frames, use small gap sealant on all the joints.
- C. The use of cutting wax (or oil) is advised to ease the self-tapping screws into the screw ports.
- D. Prior to glazing it is necessary to fit all the woolpile. The pile is mitred on the mitred sections and straight cut on straight cut sections. Woolpile is fitted to the inner panel sections only.

2. GLAZING INSTRUCTIONS

NOTE. All glazing is of the wrap around type. Two sizes of glazing gasket are available. SP115 (for 4mm glass), SF116 (for 6mm glass).

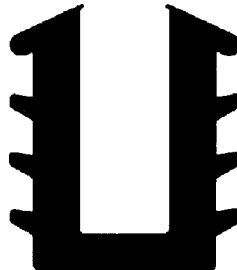

SP115/116

1. Cut a length of gasket approximately 50mm long for use as a slicing template. Start about 12mm from the top right-hand corner of the panel, wrap the channel of the gasket along the edge of the glass butting up to the offset of the gasket. Cut through the body of the gasket in line with the raised edge of the slicing template, but **DO NOT CUT THROUGH THE RAISED EDGE OF THE GASKET THAT IS BEING FITTED** G1.
2. Bend the gasket 90° round the bottom corner of the panel and hold it in position using adhesive tape G2.
3. Continue wrapping the gasket along the edge of the panel and repeat the slicing process at each corner. When all the edges have been covered use the already fitted gasket as the template for the final cut, and hold the two ends in position by placing adhesive tape along the exposed back of the gasket ends G3.



G1

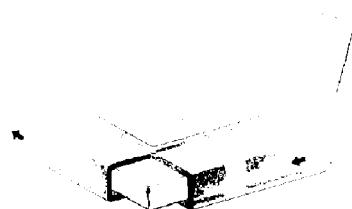

G2

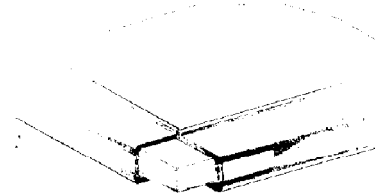

G3

3. TOOLING AND EQUIPMENT REQUIREMENTS

The following items of equipment are required to fabricate Monarch Secondary Windows:

- 1 Cross cut or pivot saw, minimum recommended blade size 10 inch - 250mm.
- 2 Tungsten tipped saw blades (require less sharpening and give a longer life).
- 3 Variable speed electric hand drill.
- 4 Felt or rubber stripped bench top avoid damage during assembly and glazing.
- 5 Felt covered racking system for stocking bar lengths (3.9m standard lengths).
- 6 No. 2 point pozi screw driver - ratchet, spiral ratched or electric screw drivers are recommended to ease and quicken assembly.
- 7 A range of standard jobbers twists drills size to include (3.5mm, 4.2mm and 4.8mm).
8. Bench vice with softjaws.
9. A selection of standard metal working and general purpose hand tools -files - punches - mallets - pliers etc.

In addition to standard items of work shop tooling the special drill jigs illustrated in this section are essential to ensure accurate and repeatable positioning of the drilled holes and to quicken the fabrication procedure. Depending on the types of window and method of fixing employed, not all jigs will be required - refer to chart. For specific details on the use of each jig refer to the fabrication procedure for each type of window.

Jig. No.	Operation Details	Used on-Window Types				
		Hor. Sliders	Vertical Sliders (Bal.)	Vertical Sliders (catches)	Lift Out	Hinged
	Used for drifting holes for;					
SP200	Outer and Inner frame assy.	*	*	*	*	*
SP201	Fitting spring balances		*			
SP202	Spring retaining catches			*		
SP203	Fitting Spiral Pins			*		
SP204	Wood fix-fixing holes	*	*	*	*	
SP205	Fitting thumb screws and hinges					*
SP206	Fitting Fitch Catch	*	*			

3. TOOLING AND EQUIPMENT REQUIREMENTS CONT.

DRILL JIG SP20 – GENERAL NOTES ON USE

Select the appropriate stop positions according to the operation – refer to fabrication instructions. The stops are held in position using a wing nut. Prior to drilling ensure that the profile is sitting square on the location faces. The holes positioned symmetrically about each stop enables the frame assembly holes to be drilled through both sides of the component without changing the stop position.

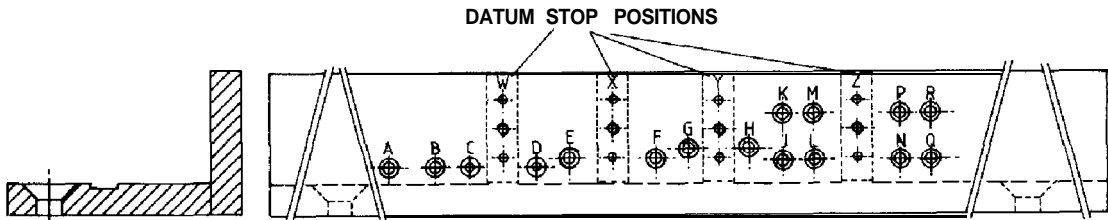

SP200

HOLES A, B TO SUIT 04,8 DRILL
 HOLES G, D TO SUIT 03,6 DRILL
 HOLES E to Q TO SUIT 04,2 DRILL

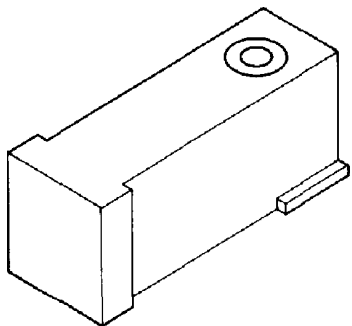

SP201 DRILL SIZE 03,5mm

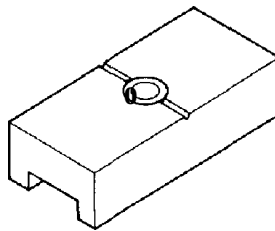

SP202 DRILL SIZE 08.5mm

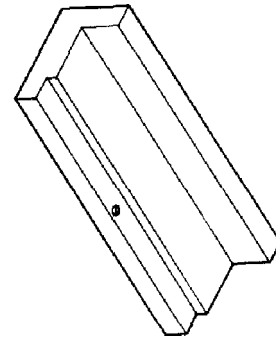

SP203 DRILL SIZE 02,0mm

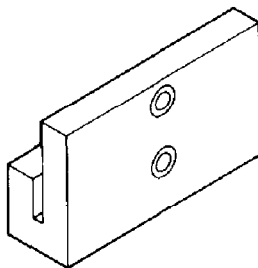

SP204 DRILL SIZE 04,5mm

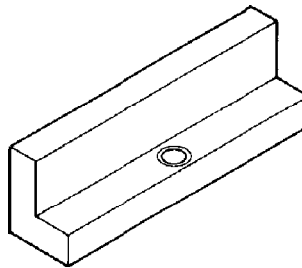

SP205 DRILL SIZE 05,1 mm
05,2 mm

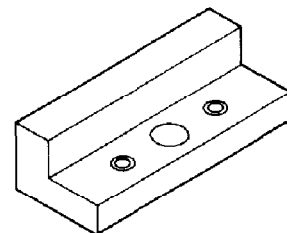

SP206 DRILL SIZE 02,8mm

4. HORIZONTAL SLIDING WINDOW

COMPONENT REQUIREMENTS

Item	Part No.	Description	Quantity	Fix	Used For
1	S1	Clip in trim - Alum	A/R	C	Concealing fixing screws
2	SP110	Clip in trim - UPVC	A/R	C	Concealing Fixing Screws
3	S2	Outer Frame	See Formula	C	
4	S7	Inner frame handle short	See Formula	-	
5	S8	Inner frame interlock	See Formula	-	
6	S9	Inner frame handle long	See Formula	-	
7	S10	Inner frame interlock 3 pane	See Formula	-	
8	S13	Large infill	See Formula	-	
9	S25	Inner frame top & bottom rails	See Formula	-	
10	ASP106	Catch	2 off	-	
11	ASP107	Skid (optional)	2 per panel	-	
12	ASP128	Roller (optional)	2 per panel	-	
13	ASP135	Fitch catch assembly	1 off	-	
14	ASP137	Bow spring (catch)	2 off	-	
15	AF185	No. 6x½ Csk S/T Screw	4 per pane	-	Assembly of inner frame
16	AF192	No. 8x1" Pan Head S/T Screw	8 off	C	Assembly of outer frame
17	AF182	No. 8x2" Pan Head Wood Screw	A/R	C	Fixing to primary window
18	AF197	No. 6x3/4" Pan Head S/T Screw	A/R	-	Fixing rollers
19	ASP125	Seal	A/R	-	Seal between existing and secondary
20	C505	Woolpile	A/R	-	3 panel interlocks only
21	C506	Woolpile	A/R	-	Inner frame sections
22	C507	Woolpile	A/R	-	2 pane interlocks only
23	ASP115	Glazing gasket	A/R	-	4mm gasket
24	ASP116	Glazing gasket	A/R	-	6mm glass

ADDITIONAL REQUIREMENTS FOR WOOD FIX WINDOW

25	S18	Outer frame	See Formula	W	Jambs Head and cill
26	S19	Outer frame	See Formula	W	
27	AF183	No. 8x2¼ CSK Wood Screw	A/R	W	
28	AF188	No. 8x1½ CSK S/T Screw	8 off	W	

NOTE: Fitch Catches (SP135) can be used on horizontal windows in place of the catches (SP106)
1 off required for 2 and 3 pane window. 2 off required for 4 pane.

C - Denotes for use on concealed fix windows only.
D - Denotes for use on wood fix windows only.

4. HORIZONTAL SLIDING WINDOWS

4.2 COMPONENT IDENTIFICATION



S1

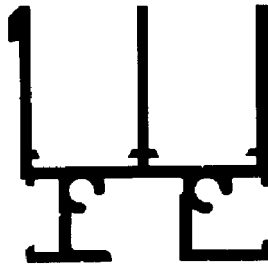

S2

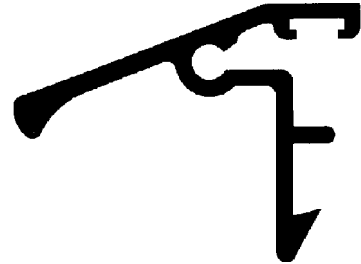

SP106



S7



S8

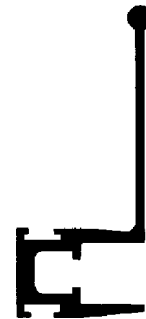

S9



S10



S25



S13

Woodfix Outer Frame Profiles

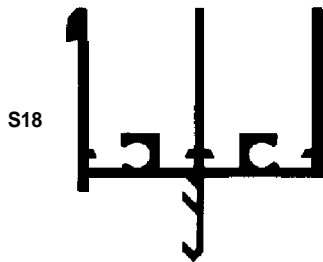

S18

JAMBS

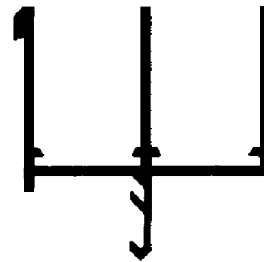

S19

HEAD & CILL

4. HORIZONTAL SLIDING WINDOWS

4.3 COMPONENT AND GLASS FORMULA

Description	Component	Concealed Fix		Wood Fix	
		Section No.	Size	Section No.	Size
Outer frame	Head	S2	W	S19	W
	Cill	S2	W	S19	W
	Jambs	S2	H	S18	H
	Infill	S13	W - 3 3	SF3	W - 4 7
2 Pane L/H Inner Frame	Top Rail	S25	A1-20	S25	A-27
	Bottom Rail	S25	A1-20	S25	A-27
2 Pane R/H Inner Frame	Top Rail	S25	A2-20	S25	A2-27
	Bottom Rail	S25	A2-20	S25	A2-27
Glass L/H Pane R/H Pane		Width = A1 - 43 Height = H - 81 Width = A2 - 43 Height = H - 81		Width = A1 - 50 Height = H - 95 Width = A2 - 50 Height = H - 95	
3 Pane L/H Inner Frame	Top Rail	S25	B1-20	S25	B1-27
	Bottom Rail	S25	B1-20	S25	B1-27
3 Pane Centre Inner Frame	Top Rail	S25	B2+18	S25	B2+18
	Bottom Rail	S25	B2+18	S25	B2+18
3 Pane R/H Inner Frame	Top Rail	S25	B3-20	S25	B3-27
	Bottom Rail	S25	B3-20	S25	B3-27
Glass L/H Pane Centre Pane R/H Pane		Width = B1-43 Height = H-81 Width = B2-5 Height = H-81 Width = B3-43 Height = H-81		Width = B1-50 Height = H-95 Width = B2-50 Height = H-93 Width = B3-50 Height = H-95	
4 Pane L/H Inner Frame	Top Rail	S25	C1-20	S25	C1-27
	Bottom Rail	S25	C1-20	S25	C1-27
4 Pane L/H Centre Pane	Top Rail	S25	C2+18	S25	C2+18
	Bottom Rail	S25	C2+18	S25	C2+18
4 Pane R/H Centre Pane	Top Rail	S25	C3+18	S25	C3+18
	Bottom Rail	S25	C3+18	S25	C3+18
4 Pane R/H Pane	Top Rail	S25	C4-20	S25	C4-27
	Bottom Rail	S25	C4-20	S25	C4-27
Glass L/H Pane L/H Pane (Centre) R/H Pane (Centre) R/H Pane		Width = C1-43 Height = H-81 Width = C2-5 Height = H-81 Width = C3-5 Height = H-81 Width = C4-43 Height = H-81		Width = C1-50 Height = H-95 Width = C2-5 Height = H-95 Width = C3-5 Height = H-95 Width = C4-50 Height = H-95	

All vertical members (stiles interlockers) S7, S8, S9 and S10 should be cut to H-58 (concealed fix) & H-72 (wood fix).

Glass height should be H-81 (concealed fix), H-95 (wood fix). Details of where to use the various stile/interlockers are illustrated on assembly drawings.

Clip in cover trim should be mitre cut to H and W dimensions (concealed fix).

IMPORTANT NOTE - PLEASE NOTE CLIP IN TRIM IS HANDED PRIOR TO CUTTING.

When using a fitch catch (SP135) IN PLACE of the slide on handles (SP106) it is necessary to add 8mm to the rail lengths determined from the above formula on the left and right hand panels only. (Both panels on a 2 pane).

This will ensure minimal movement of the panels when the catch is engaged. The glass sizes should also be adjusted in accordance.

4. HORIZONTAL SLIDING WINDOWS**4.4 FABRICATION PROCEDURE****OUTER FRAME**

1. Mitre cut the outer frame components to 'W' and 'H' dimensions
2. Drill the frame assembly holes in the head and cill (or jambs) using jig SP200.
Use holes 'L' and 'M' and 'N' and 'P' about stop 'Z' CONCEALED FIX.
Use holes 'J', 'K' and 'Q', 'R' WOODFIX. Drill size 4.2mm.

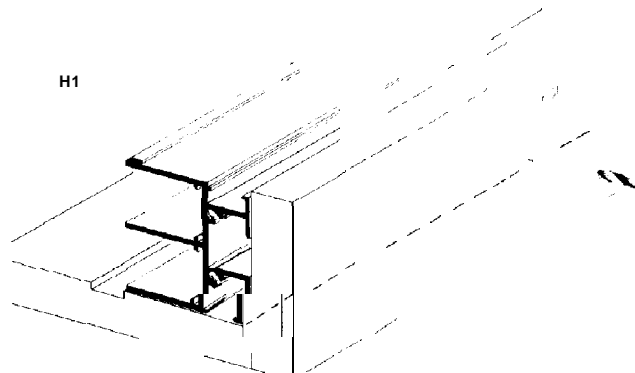

3. If using skids the large infills S13 are required. Square cut to length (See formula) and slide into the cill prior to assembly of the outer frame. No infills are required when using roller assemblies.
4. Assemble the outer frame using screws AF192 or F188 Woodfix (H2).

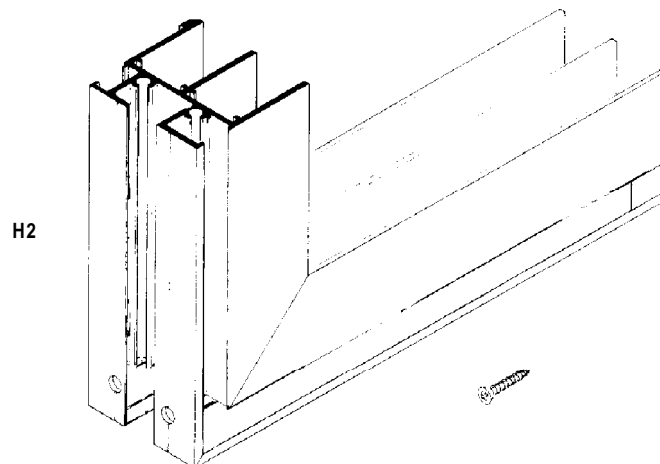

4. HORIZONTAL SLIDING WINDOWS

INNER FRAME

5. Rout the ends of the interlockers as shown in (H3) 20mm from the top and 12mm from the bottom.

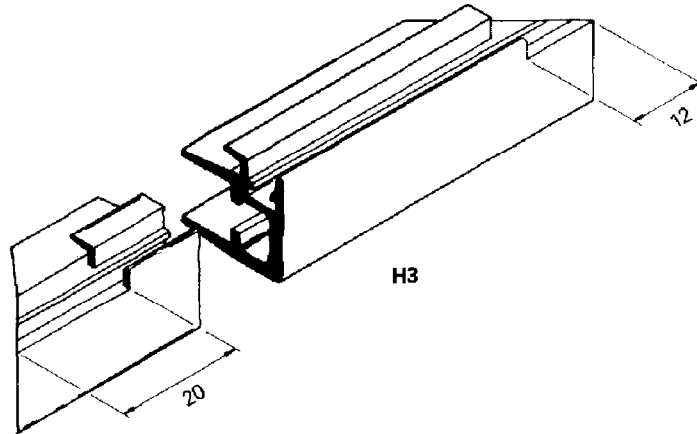

6. When using skids Drill holes for the skids 4.8 using jig SP200 holes 'A' and 'B'. NOTE The centre of the skid should be positioned a minimum of 40mm from the end of the rails. (H4).

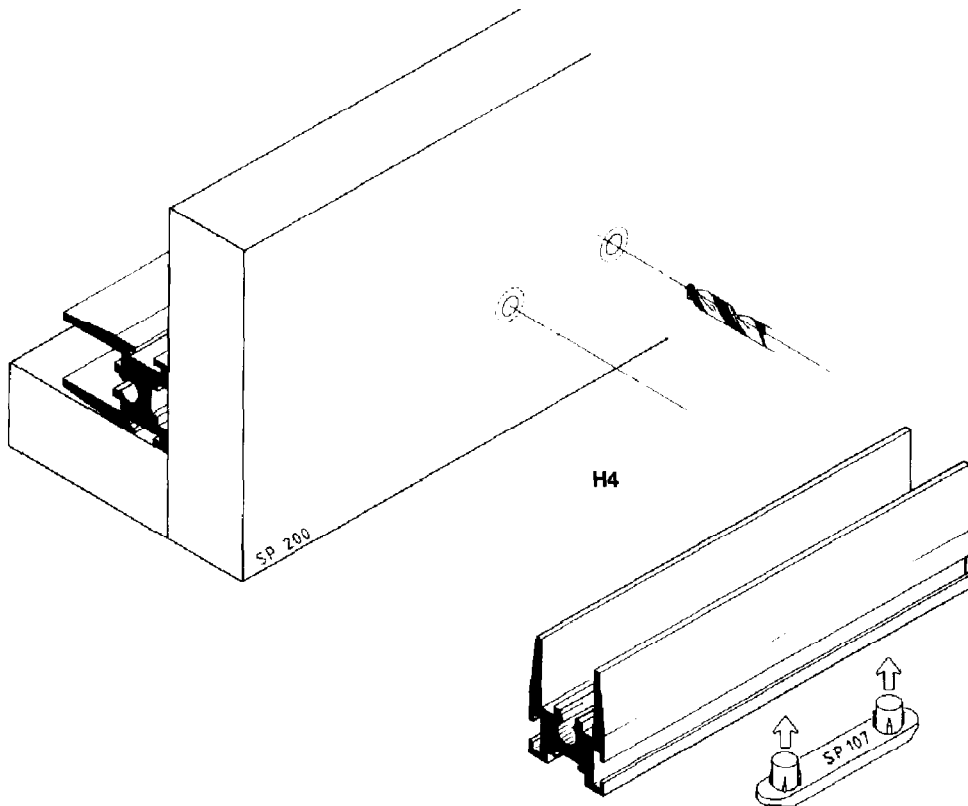

4. HORIZONTAL SLIDING WINDOWS**4.4 HORIZONTAL SLIDING WINDOW**

7. Drill the inner frame assembly holes in the stiles $\varnothing 3.5\text{mm}$. Use jig SP200 holes 'C' and 'D' about stop 'W' - Countersink the holes to 0.8 except where using roller assemblies.
8. Cut the stile handle sections S7 and S9 at 20° angles as shown in (H5) in order to facilitate fittings of the panels. Alternatively the handles can be cut back square to suit individual requirements.

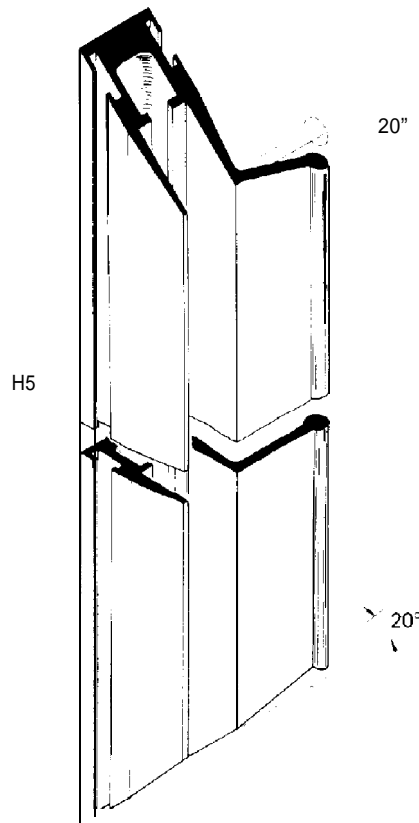

9. Slide the catches onto the handles but do not insert the bow springs until the panels have been glazed - this will prevent the bow springs from marking the handle should it be necessary to reposition the catches
10. Glaze the panels according to the general instructions provided on page 4 - assemble the frames using screws F185 except where fitting the rollers (See 12).
11. When using skids Press the skids into the $\varnothing 4.8\text{mm}$ holes in the rails prior to fitting the panels (H4).

4.5 HORIZONTAL SLIDING WINDOWS**4.1 FABRICATION PROCEDURE (CONTIN.)**

12. When using rollers Fit the roller retaining bracket and clamp to the panel (H6). Place the rollers into the cill section the correct way round (ie) the location pads facing towards the stiles/interlockers. The rollers must be positioned each side of the panel to enable it to be lifted into the frame. Manoeuvre the roller under the retaining brackets and press the panel onto the roller assemblies to locate. Check correct location of the rollers by lifting the panel slightly. Check the action of the rollers.
NOTE: The rollers should be initially set on the central setting of the roller carriage.

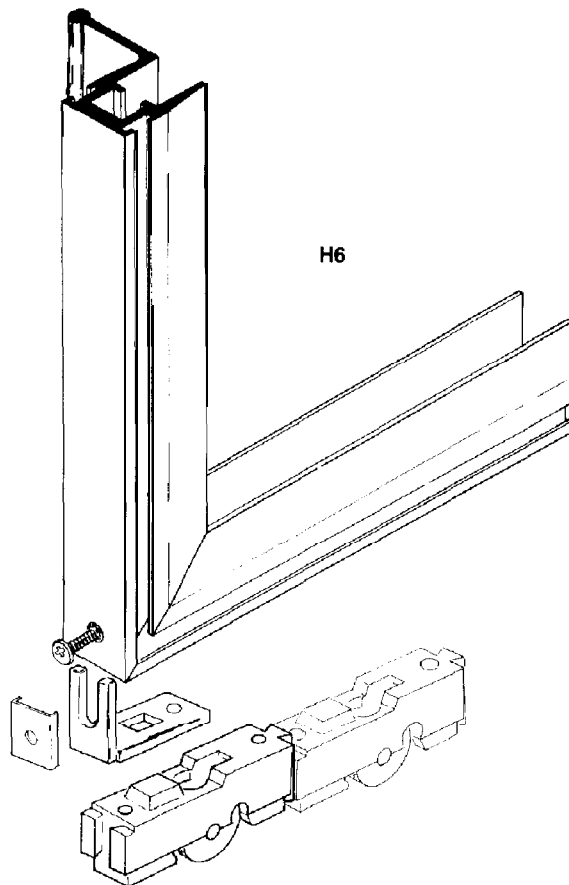
**ADDITIONAL NOTES ON ROLLERS**

Three separate axle positions have been incorporated into the carriage to provide a facility to adjust the roller height if required. The maximum recommended working load per roller should be restricted to 9 kg (20lbs). For large panels the rollers should be linked in tandem.

4.6 HORIZONTAL SLIDING WINDOWS (CONTINUED)

4.6 ASSEMBLY DRAWINGS

* Fitch Catch Position

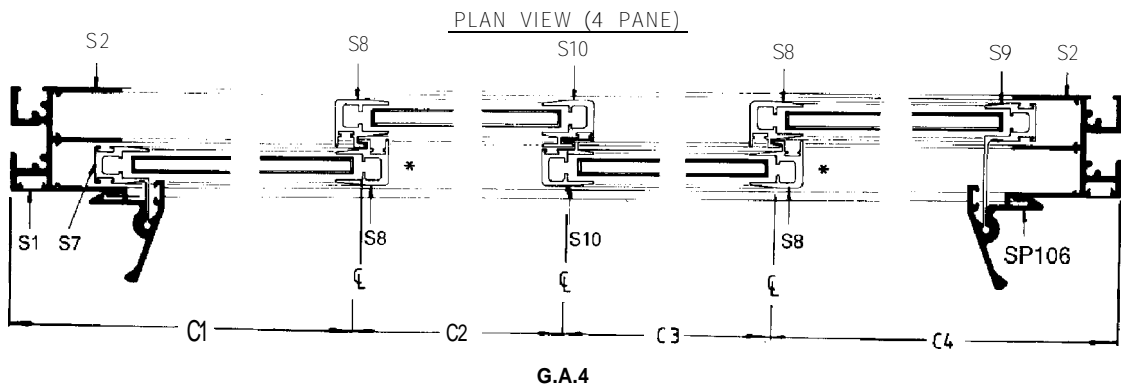
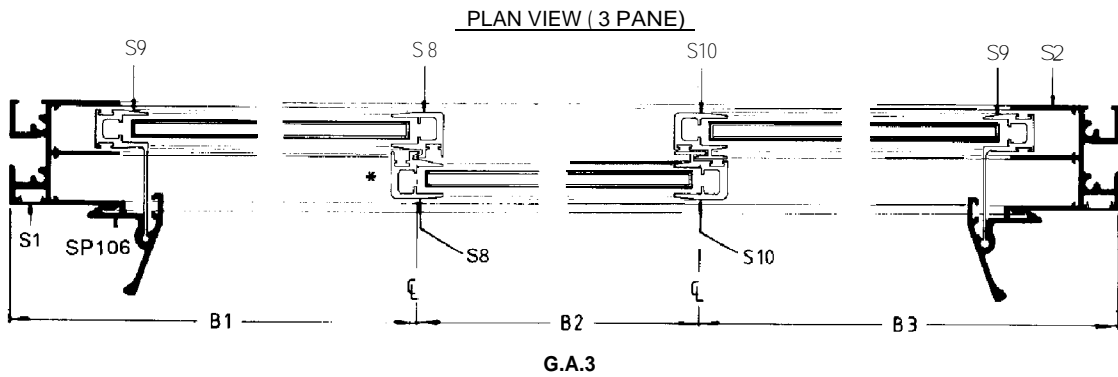
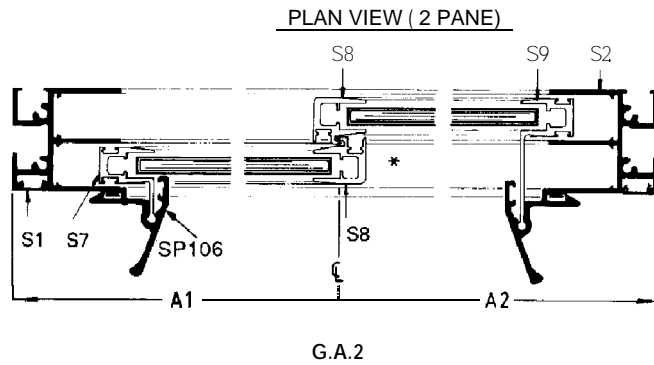

5. VERTICAL SLIDING WINDOW WITH BALANCES

COMPONENTS REQUIREMENTS

Item	Part No.	Description	Quantity	Fix	Used For
1	S1	Clip in Trim-Alum	See Formula	C	Concealing Fixing Screws
2	SP110	Clip in Trim-UPVC	See Formula		Concealing Fixing Screws
3	S2	Outer frame	See Formula	C	Short handle 2 pane Long handle
4	S7	Inner frame rails	See Formula		
5	S8	Inner frame interlock	See Formula		
6	S9	Inner frame rails	See Formula		
7	S13	Large infill	See Formula		
8	S25	Inner frame stiles	See Formula		
9	ASP100	Balance mounting foot	See Formula		
10	ASP101	Top anti-crab	4		
11	ASP102	Bottom anti-crab	4		
12	ASP108	Top stop	2		
13	ASP109	Bottom stop	2		
14a	ASP135	Fitch catch assembly	1	C	Fitch catch to interlocker
14b	E195	No. 6X3/8" Posi S/T C/S	A/R		Fitch catch plate to interlocker
14c	E196	No. 4X3/8" Posi S/T P/H	A/R		Fixing to primary window
75	AF128	No. 8X2" Pan Head Wood Screw	A/R		Assembly of inner frame
16	AF185	No.6 X 3/4" CSK S/T Screw	8		Fixing stops and balances
17	AF186	No.8 X 1" CSK S/T Screw	4		Assembly of outer frame
18	ASP192	No.8 X 1" Pan Head S/T Screw	A/R		Seal between existing and secondary
19	ASP125	Seal	A/R		Inner frame stiles and rails
20	C506	Woolpile	A/R		Inner frame interlockers
21	C507	Woolpile	A/R		4mm glass
22	ASP115	Glazing gasket	A/R	6mm glass	
23	ASP116	Glazing gasket	A/R		

ADDITIONAL REQUIREMENTS FOR WOOD FIX WINDOW

24	S18	Outer frame	See Formula	W	Head and cill Jamb section
25	S19	Outer frame	See Formula	W	
26	AF183	No.8 X 2 1/4" CSK S/T Screw	A/R	W	
27	AF188	No.8 X 1 1/2" CSK S/T Screw	8	W	

C - Concealed Fix only

W - Woodfix only

5. VERTICAL SLIDING WINDOWS WITH BALANCES

5.2 COMPONENT IDENTIFICATION



S1

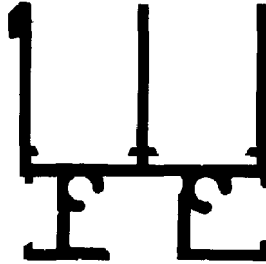

S2



S13



S7



S8

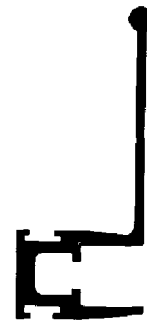

S9



S25

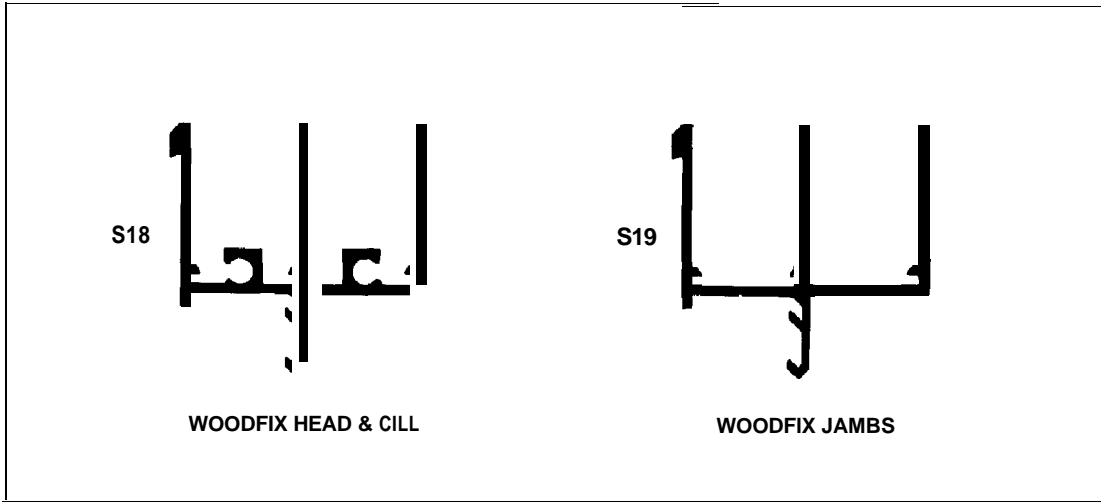

5. VERTICAL SLIDING WINDOWS WITH BALANCES

5.4 COMPONENT AND GLASS FORMULA (assembly drawing see page 22)

Description	Component	Concealed Fix		Wood Fix	
		Section No.	Size	Section No.	Size
Outer frame	Head	S2	W	S18	W
	Cill	S2	W	S18	W
	Jambs	S2	H	S19	H
Top Sash	Infill	S13	W-33	S13	W-47
	Top Rail	S9	W-58	S9	A-72
	Bottom Rail	S8	W-58	S8	A-72
Lower Sash	Stiles	S25	A2-14	S25	A2-21
	Top Rail	S8	W-58	S8	W-72
	Bottom Rail	S7	W-58	S7	W-72
Glass Sizes – Top Pane Bottom Pane	Stiles	S25	A1-20	S25	A1-27
		Width = W-81 Height = A2-37 Width = W-81 Height = A1-43		Width = W-95 Height = A2-44 Width = W-95 Height = A1-50	

CALCULATIONS TO DETERMINE SPRING BALANCE LENGTHS

$$\text{UPPER SASH BALANCE LENGTH} = (A2 - 46.5) \text{ mm} = \frac{(A2 - 46.5)}{25.4} \text{ inches}$$

When ordering specify size of upper sash balance rounded down to nearest inch.

$$\text{LOWER SASH BALANCE LENGTH} = \frac{(H - 55.5) \text{ mm}}{2} = \frac{(H - 55.5)}{2 \times 25.4} \text{ inches}$$

When ordering specify size of lower sash balance rounded up to the nearest inch.

In addition to the above sizes the spring balance supplier will require the following information:-

- : Overall width of window
- : Overall height of window
- : Glass thickness
- : Quantity of each size.

5. VERTICAL SLIDING WINDOW WITH BALANCES**5.0 FABRICATION INSTRUCTIONS****OUTER FRAME**

1. Mitre cut the outer frame components to 'W' and 'H' dimensions.
2. Drill the frame assembly holes in the head and cill (or jambs) 10.8mm from each end. Use holes 'L' and 'M' and 'N' and 'P' about stop 'Z', drill size 4.2mm (CONCEALED FIX). Use holes 'J' and 'K' and 'Q' and 'R' about stop 'Z' (WOODFIX) hole position from each end. Refer to page (A?) to show profile in position on drill jig.
3. Drill 2 holes $\varnothing 3.5\text{mm}$ in the top of each jamb section by sliding drill jig SP201 into each of the section channels. Holes position 29mm from the top of the jamb (V1).

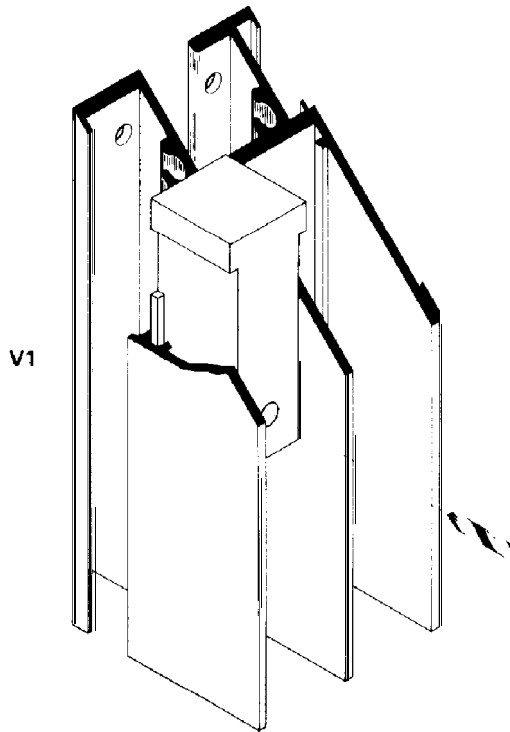

4. Cut the top stops for the bottom sash to length (suggested minimum length 45mm). Drill fixing hole 13.5mm from the top end $\varnothing 5.2\text{mm}$ and countersink to $\varnothing 8\text{mm}$.
5. Cut the bottom stops (suggested minimum length 105mm). Drill a fixing hole $\varnothing 5.2\text{mm}$ in the centre of the stops and countersink to 8mm. For windows with unequal "split" the stops will need to be extended.
6. Secure the spring balances and top stops (for the bottom sash) to the inside channel of the jamb through the $\varnothing 3.5$ holes. Use fixing screw F186 (V2A). To secure the spring balances (for the top sash) to the outside channel of the jambs through the $\varnothing 3.5$ holes. Use the fixing screws F186 (V2B).

5. VERTICAL SLIDING WINDOW WITH BALANCES

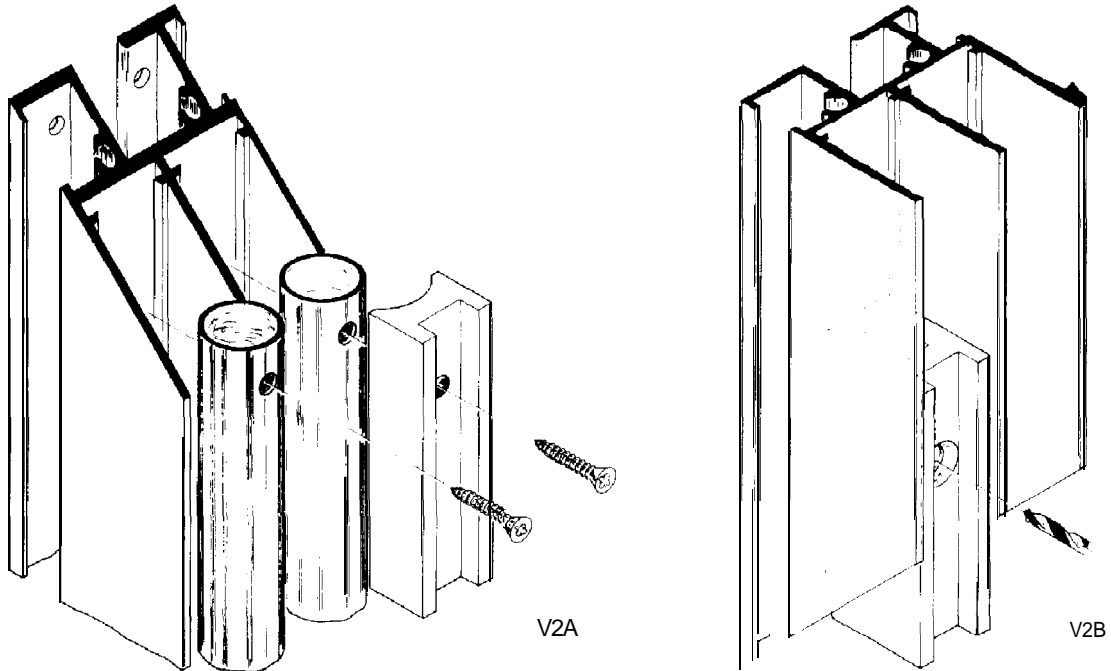

7. Drill 03.5 holes in the inside channel in the bottom of the jamb for fixing the lower stops for the top sash. Use the bottom stops, to mark out the hole position.
8. Cut the large infill section (S13) to length (see formula) and slide into the outer channel of the cill section for the lower sash.
10. Screw the cill to the jambs using fixing screw F192 (F188 WOODFIX) leaving the head off until the inner frames have been assembled

INNER FRAME

11. Mitre cut to length all the inner frame components-stiles and rails (refer to the formula on p17).
12. Drill $\varnothing 3.5$ mm holes in the top and bottom rails 6.5mm from each end, using drill jig SP200 - holes 'C' and 'D' about stop 'W'.
13. Rout off 12mm from each end of the rail interlocks S8 for the upper sash. Rout off 31mm clearance in the centre of the bottom rail to accept the fitch catch keep plate. Using the keep as a template drill 2 $\varnothing 3.2$ clearance holes to accept the securing screws (V3).

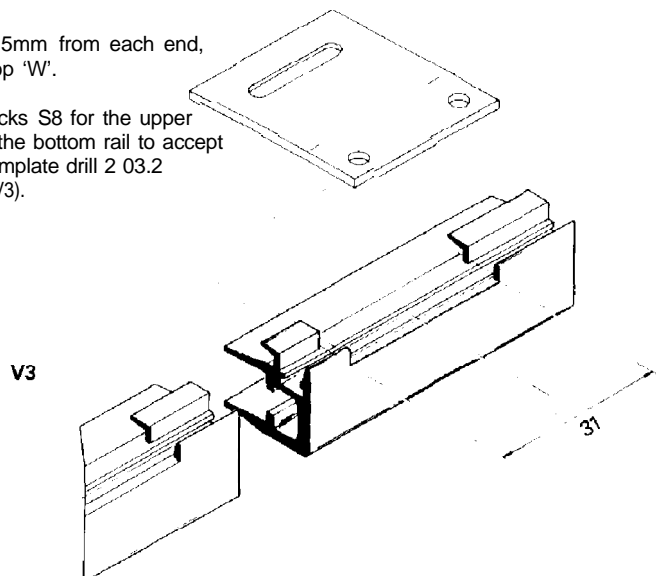

5. VERTICAL SLIDING WINDOW WITH BALANCES

5.5 FABRICATION INSTRUCTIONS (contin)

14. Rout off 12mm from each end of the top rail of the lower sash. Rout the centre of the rail 40mm wide to accept the fitch catch. Drill 2 holes $\varnothing 2.8$ to fix the fitch catch using drill jig SP206. (V4)

NOTE: Ensure the holes are positioned centrally with respect to the upstand rebate.

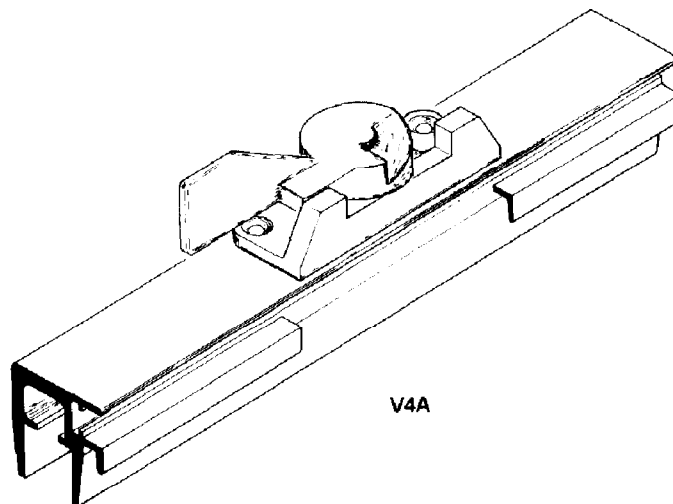
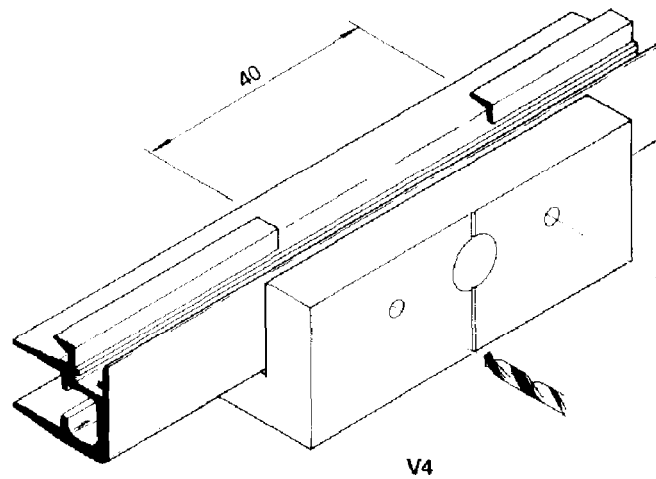

5. VERTICAL SLIDING WINDOW WITH BALANCES

5.5 FABRICATION INSTRUCTIONS (contin)

15. Glaze according to the general instructions provided on page 4 and during this process fit the balance hook SP100 to the bottom of the panels, and the top anti-crabs SP101 to the top rails. (V5)
16. Slide the interlocked panels into place from the top of the frame. Fit Head. Ensure that the hooks engage in the balances and adjust as per the Caldwell literature. Check the action of the balance (V5A)

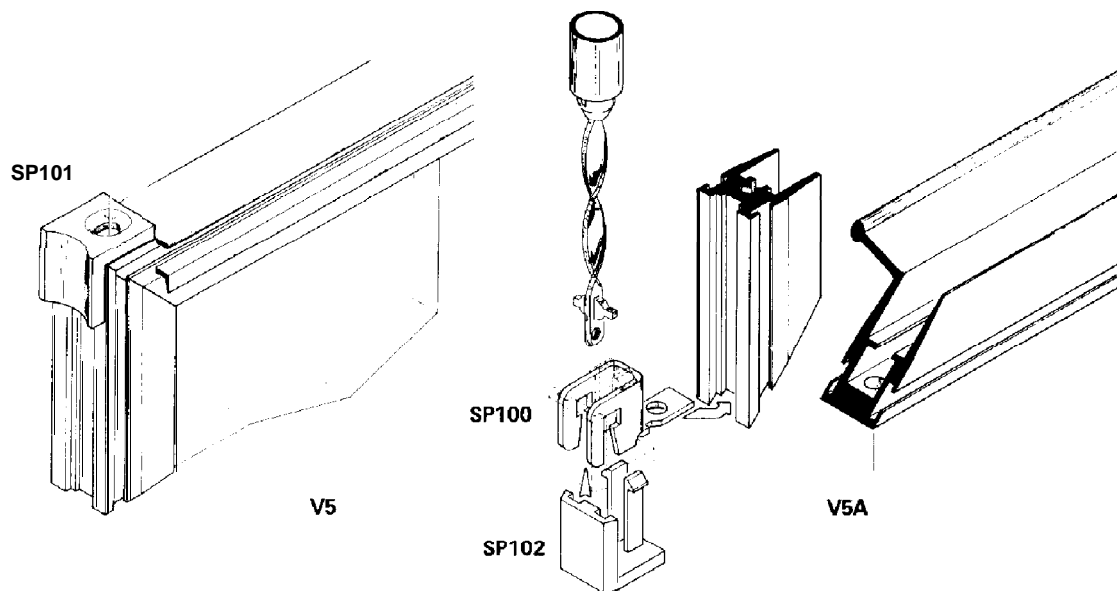

5. VERTICAL SLIDING WINDOWS WITH SPRING BALANCES

5.3 ASSEMBLY DRAWINGS



PLAN VIEW

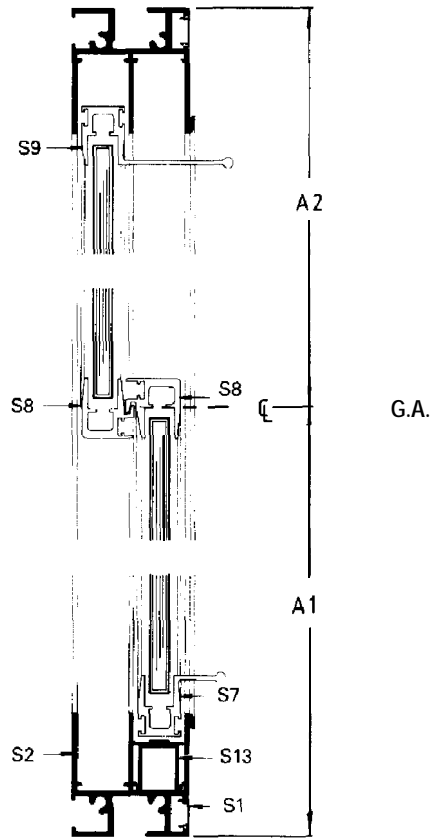

SIDE VIEW

6. VERTICAL WINDOWS WITH SPRING RETAINING CATCHES

6.1 COMPONENT REQUIREMENTS

Item	Part No.	Description	Quantity	Fix	Used For
1	S1	Clip in trim -Alum	See Formula	C	Concealing fixing screws
2	SP110	Clip in trim - UPVC	See Formula	C	Concealing fixing screws
3	S2	Outer frame	See Formula	C	Head and Jambs section
4	S3	Outer frame	See Formula	C	Cill section
5	S8	Inner frame interlock	See Formula		
6	St1	Inner frame bottom rail	See Formula		
7	S13	Large infill	See Formula		
8	s14	Small infill	See Formula		
9	S25	Inner frame stiles	See Formula		
10	ASP104	Retaining catch	4		
11	ASP105	Catch block	4		
12	ASP107	Skid	4		
13	ASP120	Compression spring	4		
14	ASP121	Pin	4		
15	ASP138	Bow spring inner frame	4		
16	AF182	No. 8x2" Pan Head Wood Screw	A/R		Fixing to primary window
17	AF184	No. 2x1/4" CSK S/T Screw	4		Fixing bow spring
18	AF185	No. 6x3/4" CSK S/T Screw	8		Inner frame assembly
19	AF186	No. 8x1/2" CSK S/T Screw	8		Outer frame assembly
20	ASP125	Seal	A/R		Seal between primary and secondary
21	C506	Woolpile	A/R		Inner frame
22	C507	Woolpile	A/R		Interlocker

REQUIREMENTS FOR WOOD FIX WINDOW

23	S18	Outer frame	See Formula	W	Head section
24	S19	Outer frame	See Formula	W	Jamb section
25	S20	Outer frame	See Formula	W	Cill section
26	AF183	No. 8x2 1/4" CSK Wood Screw	Am	W	Fixing to primary
27	AF192	No. 8x1" Pan Heas S/T Screw	8	W	

C - Denotes for use on concealed fixed windows only.

W - Denotes for use on wood fix windows only.

6. VERTICAL SLIDING WINDOWS WITH SPRING RETAINING CATCHES

6.2 COMPONENT IDENTIFICATION



S1

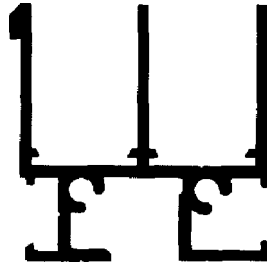

S2

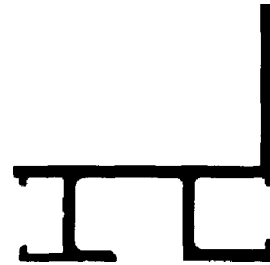

S3



S8



S25

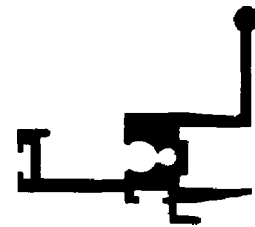

S11



SD



s14

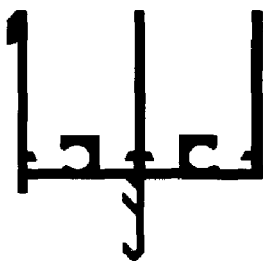

S18

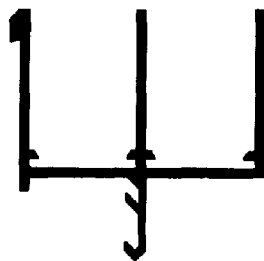

S19

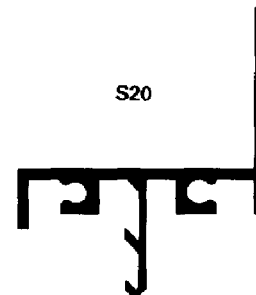

S20

6. VERTICAL SLIDING WINDOWS WITH SPRING CATCHES

6.4 COMPONENT AND GLASS FORMULA

Description	Component	Concealed Fix		Wood Fix	
		Section No.	Size	Section No.	Size
Outer frame	Head	S2	W	S18	W
	Cill	S3	W	S20	W
	Jambs	S2	H-13.5	S19	H-25.5
	Large Infill	S13	H-30	S13	H-52
	Small Infill	S14	H-30	S14	H-52
Top Sash	Top Rail	S25	W-58	S25	W-72
	Bottom Rail*	S11	W-58	S11	W-72
	Stiles	S25	A2-20	S25	A2-27
Bottom Sash	Top Rail	S8	W-58	S8	W-72
	Bottom Rail*	S11	W-58	S11	W-72
	Stiles	S25	A1-21	S25	A1-33
Glass Sizes		Concealed Fix		Wood Fix	
Top Pane		Width = W-81 Height = A2-43		Width = W-95 Height = A2-50	
Bottom Pane		Width = W-81 Height = A1-44		Width = W-95 Height = A1-56	

*Refer to fabrication notes on page 27

6. VERTICAL SLIDING WINDOWS WITH SPRING CATCHES

6.5 FABRICATION INSTRUCTIONS

OUTER FRAME

1. Mitre cut the head section to dimension 'W'.
2. Mitre cut the top of the jambs to fit to the head and square cut to fit to the cill (dimension H – 13.5).
3. Square cut the cill section to dimension 'W'. Rout off the cill upstand to a depth of 23mm, 36.5mm from each end of cill (U1).
4. Drill the frame assembly holes in the head using drill jig SP200. Use holes 'L' and 'M' and 'N' and 'P' about stop 'Z' (CONCEALED FIXED). Use holes 'J' and 'K' and 'Q' and 'R' about stop 'Z' (WOODFIX). Drill size 4.2mm.
5. Drill 2 holes $\varnothing 4.2\text{mm}$ through each end of the cill section 10mm from each end to line up with the screw ports in the jambs. NOTE: A thin offcut of section S2 can be used as a template to assist marking out the positions (U 1).

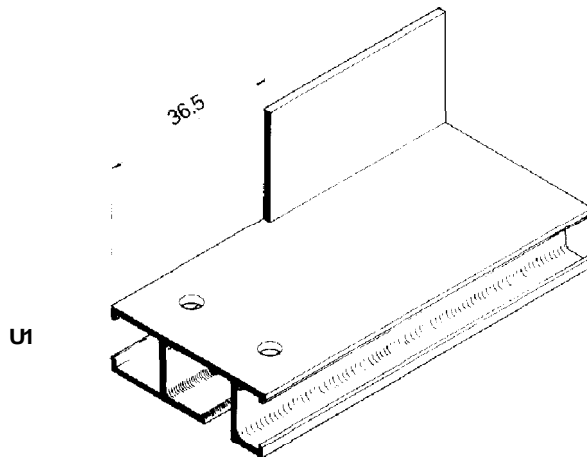

6. Cut to length the two large and two small infill sections.
7. Drill the holes in the infill sections to accept the catches using drill jig SP202 – drill size $\varnothing 8.5$. It is suggested that the holes are drilled 49mm from the top end of the infills for the top panel and 11 mm and 54mm from the bottom end of the infills for the bottom panel. Additional holes can be drilled according to individual requirements, prior to final assembly by using the panel positions to serve as an indicator. NOTE: It is important that the holes are positioned identical distances from the bottom end of the infills to ensure that the panels are square to the outer frame when in the open position (U2).

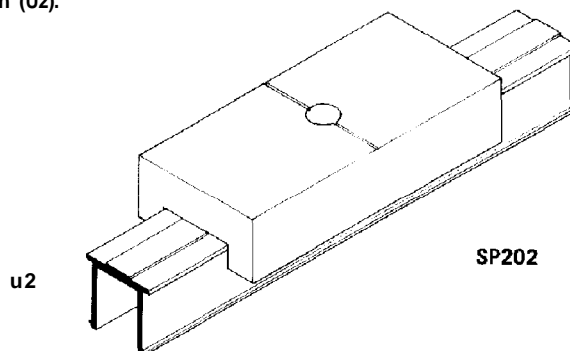

6. VERTICAL SLIDING WINDOWS WITH SPRING CATCHES

6.5 FABRICATION INSTRUCTIONS (Contin)

INNER FRAMES

8. Mitre cut the stiles and top rails to length (consult formula). Mitre cut the bottom rails to dimension W-28 and then square cut across the spring catch channel to dimension W-58 (U3).
9. Drill the inner frame assembly holes using drill jig SP200. Use holes 'C' and 'D' about stop W' -drill size 3.5mm. Countersink the holes in the top rail of the lower panel to 8mm.
10. Drill the holes to accept the spiral pins in the bottom rails (both panels), using drill ends, drill depth to be not more than 18mm below the top surface of the jig. Tap in the spiral pins to fit flush into the pile groove (U3).
11. All interlock sections: i.e. top panel, bottom rail; lower panel, top and bottom rails. Rout off 18mm of interlock on S11 sections and 18mm off interlock and upstand on S8 sections.

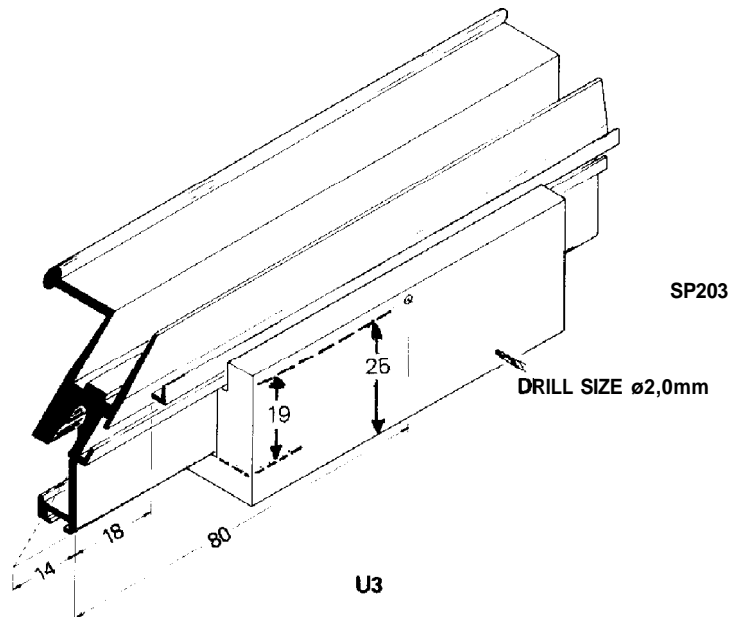

6. VERTICAL SLIDING WINDOWS WITH SPRING CATCHES

6.5 FABRICATION INSTRUCTIONS (Contin)

12. Drill the holes to accept the skids in the left hand stile sections using drill jig SP200 holes 'A' and 'B' drill size. The skids should be positioned at a minimum distance of 40mm from the end of the stile. Insert the skids into the stiles (U4).
13. Drill a $\varnothing 2\text{mm}$ hole on the centre line of each of the right hand stile sections for the bow spring securing screws. These screws must be positioned 22mm minimum from the end of the components. Fit bow springs to stiles (U4).

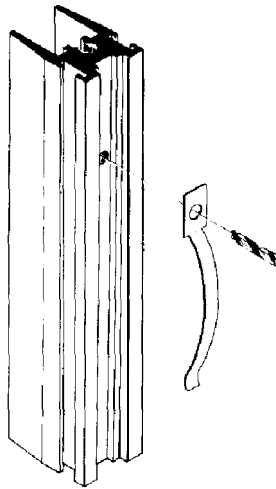

14. Glaze the panels according to the general instructions on page 4.
15. Slide the panels into the outer frame by fitting the bow springs side first and compressing the springs against the infills.
16. Check the action of the sliding panels. Mark out any additional catch positions required on the Infills. Remove the panels and drill the additional catch holes. Re-assemble the windows.

6. VERTICAL SLIDING WINDOWS WITH SPRING RETAINING CATCHES

3.3 ASSEMBLY DRAWINGS

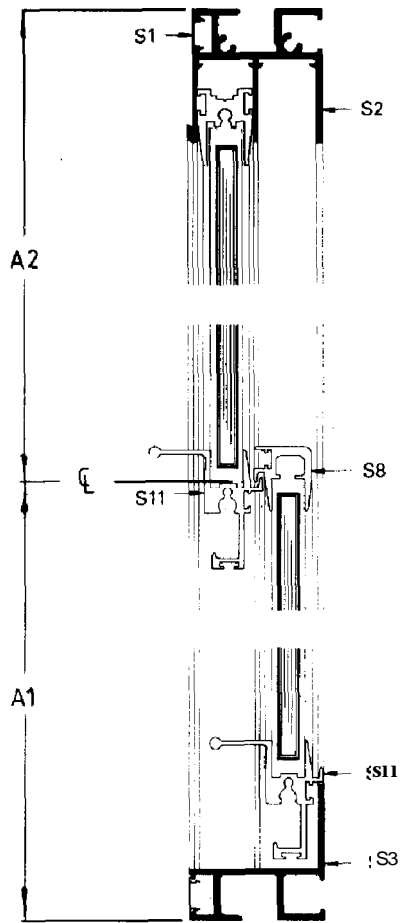

SIDE VIEW

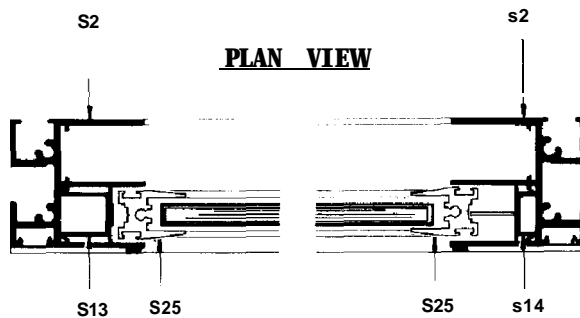

PLAN VIEW

7. LIFT OUT WINDOWS

7.1 COMPONENT REQUIREMENTS

Item	Part No.	Description	Quantity	Fix	Used For
1	S1	Clip in cover trim-Alum	See Formula	C	Concealing fixing screws
or 2	SP110	Clip in cover trim-UPVC	See Formula	C	Concealing fixing screws
3	S4	Outer frame	See Formula	C	Cill and jambs
4	S5	Outer frame	See Formula	C	Head
5	S7	Inner frame	See Formula	-	Short handle
6	S25	Inner frame	See Formula	-	Head and stiles
7	AF181	No.8x1 ¹ / ₄ " Pozi Pan Head Screw	A/R	C	Fixing secondary to primary
8	AF185	No.6x1 ¹ / ₄ " Pozi CSK S/T Screw	4	-	Assembly of inner frame
9	AF188	No.8x1 ¹ / ₂ " Pozi CSK S/T Screw		C	Assembly of outer frame
10	ASP125	Seal	A/R	C	Seal between primary and secondary
11	C506	Woolpile	A/R	-	Seal between inner and outer frame
12	ASP115	Glazing gasket	A/R	-	4mm glass
13	ASP116	Glazing gasket	A/R	-	6mm glass
14	ASP107	Skid	A/R	-	Locating Vent Cill

WOOD FIX REQUIREMENTS

15	S24	Outer frame	See Formula	W	Cill and jambs
16	S23	Outer frame	See Formula	W	Head
17	AF183	No.8x2 ¹ / ₄ " Pozi CSK Wood Screw	A/R	W	Fixing secondary to primary
18	AF192	No. 8x1" Pozi Pan Hd S/T Screw	A/R		Assembly of outer frame
19	ASP126	Seal	A/R		Seal between secondary and primary

Fixing Type C - Denotes Concealed Fix only

Fixing Type W - Denotes Woodfix only

7. LIFT OUT WINDOWS

X2 COMPONENT IDENTIFICATION



S1



S4



S5

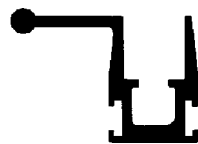

S7



S25

WOOD FIX OUTER FRAME PROFILES

S23

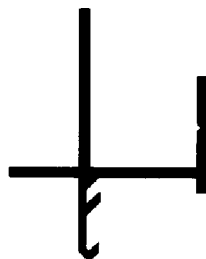

HEAD

S24

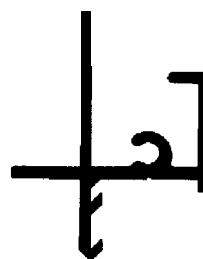

CILL & JAMBS

7. LIFT OUT WINDOWS

4.4 COMPONENT AND GLASS FORMULA

Description	Component	Concealed Fix		Wood Fix	
		Section No.	Size	Section No.	
Outer frame	Head	S5	W	S23	
	Cill	S4	W	S24	
	Jambs	S4	H	S24	H
Inner frame	Stiles	S25	H-46	S25	H - 6 0
	Top Rail	S7 (or S25)	W - 5 6	S7 (or S25)	W - 7 0
	Bottom Rail	S7	W - 5 6	S7	W - 7 0
Glass Sizes		Width = W-79 Height = H-69.5		Width = W-93 Height = H-83.5	

4.5 FABRICATION INSTRUCTIONS

OUTER FRAME

- Mitre cut the outer frame component to W and H dimensions.
- Drill the frame assembly holes in the head and cill from each end. Use holes 'E' and 'F' about stop 'X' (CONCEALED FIX). Use holes 'J' and 'Q' about 'Z' (WOOD FIX). Drill size 4.2mm.
- Assemble the outer frame using screws AF192 (concealed fix and screw) AF188 (wood fix).

INNER FRAME

- Mitre cut to length the inner frame components (refer to formula).
- Drill 2 holes $\varnothing 4.2\text{mm}$ in the bottom rail for fitting the skids. The holes should be positioned at a minimum of 40mm from the end of the rails. Use holes 'A' and 'B' on drill jig SP200.
- Glare the panels according to the general instructions on page 4 using screws F185 to assemble the inner frame.

7. LIFT OUT WINDOWS

7.3 ASSEMBLY DRAWINGS

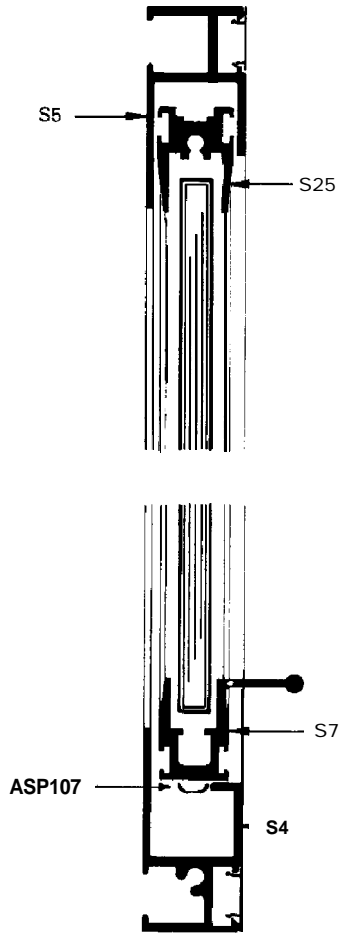

SIDE VIEW

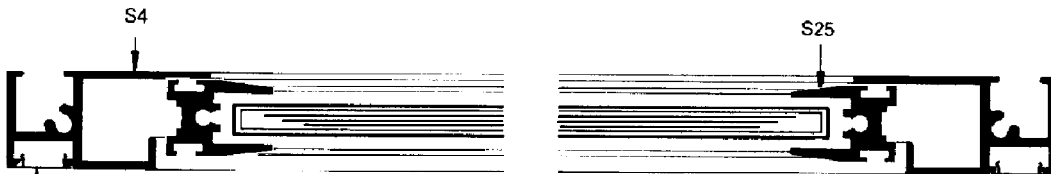

PLAN VIEW

8. HINGED WINDOWS

8.1 COMPONENT REQUIREMENTS

Item	Part No.	Description	Quantity	Fix	Used For
1	S15	Frame	See Formula		—
2	ASP103	Pressure Pad	2		Assembly of hinge
3	ASP129	Thumbscrew Assy	2		—
4	ASP130	Hinge	2		—
5	AF187	No. 8x3/4" S/T Pozi Pan	4		Assembly of frame
6	AF180	No. 8x1" Pozi Pan S/T Screw	A/R		Fixing secondary or primary
7	ASP115	Glazing gasket	A/R		4mm glass
8	ASP116	Glazing gasket	A/R		6mm glass

8.2 COMPONENTS IDENTIFICATION

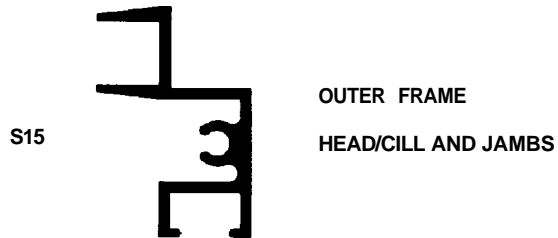

DI0

8.4 COMPONENT AND GLASS FORMULA

Description	Component	Section No.	Size
Frame	Head	S15	W
	Cill	S15	W
	Jambs	S15	H
Glass Sizes		Width = W-32 Height = H-32	

8.5 FABRICATION INSTRUCTIONS

- Mitre cut the frame section to 'W' and 'H' dimension.
- Drill the frame assembly holes in the head and cill (or jambs) from each end. Use holes 'G' and 'H' about stop 'Y'. Drill size $\varnothing 4.2\text{mm}$.
- Mark out the required positions of the hinges and thumbscrews. Drill the holes for the thumbscrews using the drill jig as shown in J1. Drill the hinge fixing holes as shown in J2. To enable panel to open full 90° a minimum of 50mm flat surface is needed to fix the hinge when hanging the panel.
- Glaze the panel according to the general instructions on page 4 using screws F187 to assemble the panel. NOTE: Due to the shape of the frame sections the use of sash cramps will ease the glazing procedure.

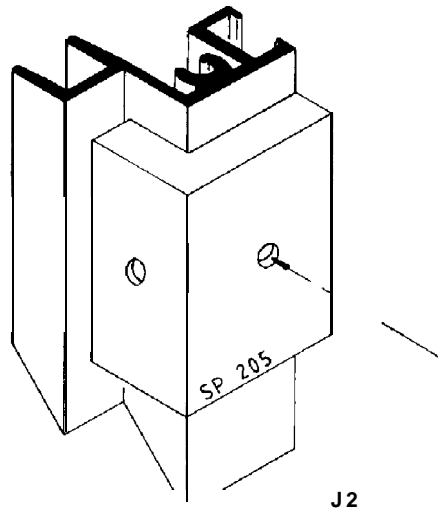
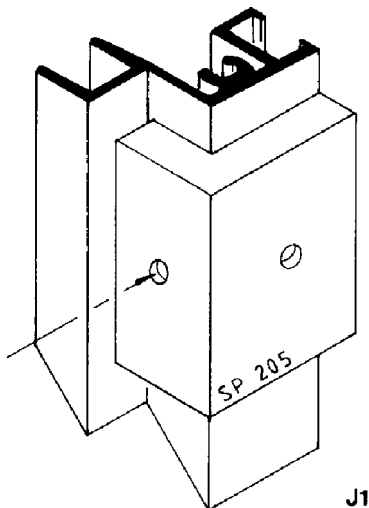



5. Fix the hinge assembly and pressure pad to the frame as shown in J3.
6. Insert the thumb screws through the section (opposite to the hinges) and retain using the arclips as shown in J4.

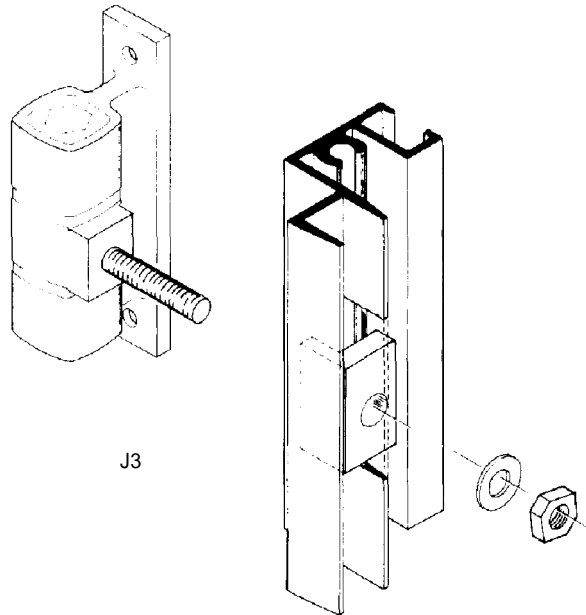

J3

7. The hinge is designed to fix directly to the primary window wood surround using screws F180. The thumbscrew keep plate supplied as part of the thumbscrew assemble reach is also fixed to the wood source using the same screws.

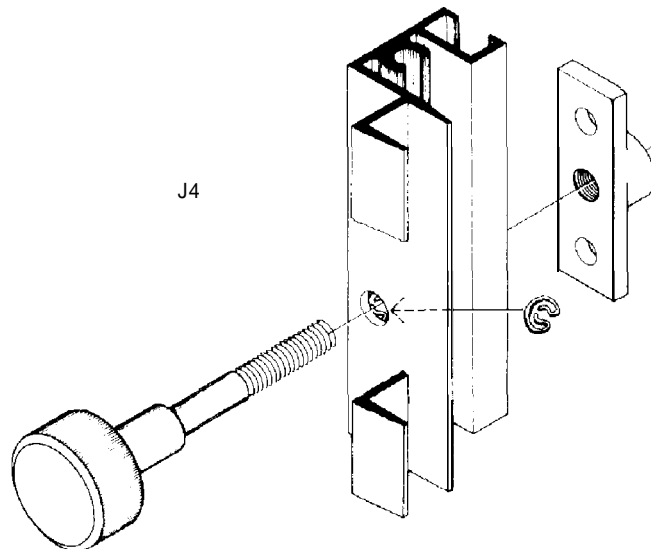

J4

8. HINGED WINDC

ASSEMBLY DRAWINGS

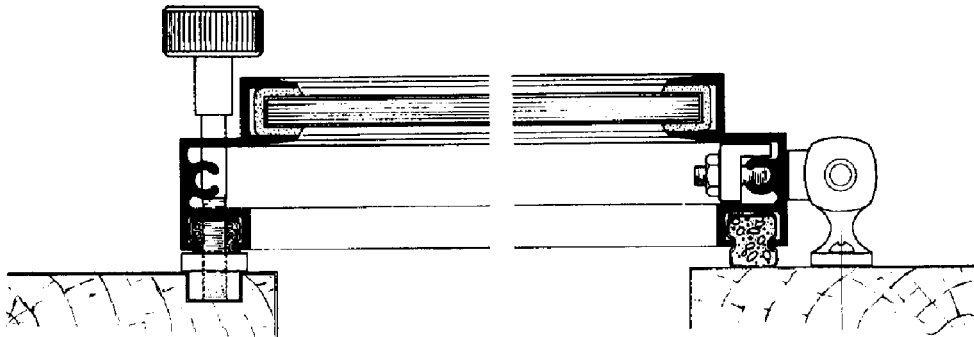

9. INSTALLATION DETAILS

1. Ensure existing frame is flat, square plumb and in reasonably stable condition.
2. Ensure when fixing the secondary window to the primary window that the relevant foam seal has been applied to the secondary.
3. Fixing screws to be positioned no more than 300mm apart.
4. In certain circumstances it may be necessary to install a soft wood liner frame to facilitate the fitment of the secondary window.