

CONTENTS

<u>A. SYSTEMS SPECIFICATION</u>	Page	Last Issue
1. Introduction	A1	01.06.01
2. Exploded Parts List	A2	01.06.01
General Arrangements	A3	01.06.01
	A4	01.06.01
	A5	01.06.01
3. Identification	A6	01.06.01
3.1 Extrusion Profiles	A6	
3.2 Plastic Trim Profiles	A6	
4. Hardware	A7	01.06.01
	A8	01.06.01
 <u>B. FORMULAE</u>		
1. Glass Calculations	B1	01.06.01
2. Balances Matrix	B2	01.06.01
 <u>C. WORKSHOP PROCEDURES</u>		
1. Safety and Important Points	C1	01.06.01
2. Tooling and Equipment	C1	
3. Factory Sub-Assembly		
3.1 Top Sash	C1	
	C2	01.06.01
3.2 Bottom Sash	C3	01.06.01
3.3 Outer Frame	C4	01.06.01
3.3.1 Trickle Vent	C5	01.06.01
3.4 Combinations	C5	
3.5 Transit	C5	
 <u>D. INSTALLATION</u>		
1. Installing the Outer Frame	D1	01.06.01
2. Fitting Balances & Restrictor Stays	D2	01.06.01
	D3	01.06.01
	D4	01.06.01
3. Installing the Upper Sash	D5	01.06.01
	D6	01.06.01
4. Installing the Lower Sash	D7	01.06.01
5. Fitting the Sash Stops	D7	
6. Fitting the Riser Blocks	D8	01.06.01
7. Accessories	D9	01.06.01
7.1 Additional Hardware Packs	D9	
7.2 Fixing Lugs	D9	
7.3 Travel Restrictor	D10	01.06.01
7.4 Horn Accessory Kit	D11	01.06.01
7.5 Glazing Gasket	D12	01.06.01
8. Installing Combinations	D13	01.06.01
8.1 Coupling Sliders	D13	
8.2 Coupling to Monafame	D13	
 <u>E. USE AND MAINTENANCE</u>		
1. Use	E1	01.06.01
2. Maintenance	E2	01.06.01
 <u>F. TECHNICAL BULLETINS</u>		

List Of Illustrations

Fig. No.	Title	Page No.
1.	Exploded Parts List	A2
	Exploded Parts List	A3
2a.	Key Sectional View	A4
2b.	Key Sectional View	A5
3.	Extrusion / Plastic Profiles	A6
4.	Hardware	A7
5.	Hardware	A8
8.	Top Sash Assembly	C1
9.	Fitting Glazing Gaskets	C2
10.	Fitting Slide Latch	C2
11.	Fitch Catch Keep Positioning	C3
12.	Bottom Sash - Top Rail Fittings	C3
13.	Jamb / Cill Infill	C4
14.	Fitting Frame to Add-On Cill	C4
15.	Trickle Vent	C5
16.	Foam Plugs	D1
17.	Fitting Buffer Stops	D1
18.	Frame Fixing Positions	D1
19.	Locating Pivot Shoes	D2
20.	View on Glider	D2
21.	Fitting the Balances	D2
22.	Fitting/Adjusting Balances (Caldwell)	D3
	Tensioning Charts	D4
23.	Positioning Pivot Shoes	D5
24.	Positioning Pivot Shoes	D5
25.	Aligning Sash with Pivot Shoes	D5
26a.	Pivot Bar/Shackle Location	D5
26b.	Pivot Bar/Shackle Location	D6
27.	Fixing the Stay to Sash	D6
28.	Locking Top Sash Slide Latch	D7
29.	Fitting Sash Stops	D7
30.	Sealing the Sash Stops	D7
31.	Riser Block	D8
32.	Riser Block Prep	D8
34a.	Fixing Lugs	D9
34b.	Fitting Travel Restrictors	D10
35.	Horn Fittings	D11
36.	Horn Fittings : Right Hand Assembly	D11
37.	Assembly of Hidden Coupling	D13
38.	VSW : Monaframe Adaptor	D13

A. SYSTEM SPECIFICATIONS

A. 1. Introduction (Figs. 1 & 2)

The Monarch thermally broken Vertical Sliding Window is designed to operate as a 'Slide and Tilt' window, although a 'Slide Only' version may be ordered. Combinations of hardware can be supplied, refer to Sapa Technical.

Made precisely to dimensions supplied by customers, the system is available in kit form complete with Caldwell tubular balances, catches and other hardware ready to fit to prepared sections. Tilting windows have as standard two pairs of stainless steel stays, these are fixed directly to the sash jambs, both sashes must be restricted to give guaranteed safety while cleaning.

The maximum weight for tilting sashes is 35Kgs and they should give an approximate fully supported cleaning angle of 40° from the vertical.

Please refer to section 'B' for all kit parameters.

We strongly recommend that the Caldwell slide latches (C523 & C524) are used irrespective of the type of balances selected.

A hidden coupling (M660) is used to join two VSW frames, whilst a slimline adaptor (M661) steps down from 96mm-75mm to link this product with the rest of the Monaframe suite. The 155mm(A992) or 190mm(A993) Monaframe cills should be used where a cill is specified.

The outer frames are butt jointed and sashes are wrap round glazed, with a full range of black glazing gaskets available to suit.

The system has been independently weather tested to BS6375 : Pt 1 and has achieved :-

Air Permeability	300 Pa
Water Penetration	300 Pa
Gust Deflection	2000 Pa

Exposure Category 2000

Please note ;

When balances and/or restrictors are procured from alternative sources, Sapa cannot and will not accept liability for the window, it is up to the fabricator to ensure that the maximum parameters within this manual are not exceeded.

It is recommended that regular inspection of ironmongery is carried out, as per 'Use & Maintenance' section, and in all cases where the sashes are dropped accidentally.

Sapa's policy is one of continual system development and we reserve the right to incorporate design improvements and changes. Every effort is made to ensure that all details are correct at time of publication. However, it is the responsibility of the customer to check the accuracy of the relevant facts and information before entering into any contract or other commitment. Up to date information is freely available from the Sapa Building Systems Webshop. All Products and systems which Sapa supply are supplied subject to Sapa's standard Terms and Conditions of Sale current from time to time.

ITEM NUMBER	CODE	DESCRIPTION
1		OUTER HEAD
2		OUTER CILL
3		LH OUTER JAMB
4		RH OUTER JAMB
5		TOP SASH TOP RAIL
6		TOP SASH LH JAMB
7		TOP SASH RH JAMB
8		TOP SASH MEETING RAIL
9		BOTTOM SASH MEETING RAIL
10		BOTTOM SASH LH JAMB
11		BOTTOM SASH RH JAMB
12		BOTTOM SASH BOTTOM RAIL
13	Z514	JAMB INFILL LH
14	Z513	JAMB INFILL RH
15	Z547	TOP RAIL INFILL
16	Z515	CILL INFILL
17	C536 W/S	FOAM PAD
18	C522	PIVOT BAR
19	C593	PIVOT SHOE
20	C530 W/E	LIFT HANDLE
21	C525 . C526	SASH LOCK
22	C528 W/E	KEEPER
23	C524 W/E	SLIDE LATCH - LOWER SASH
24	C531 W/E	POLE RING
25	C523 W/E	SLIDE LATCH - UPPER SASH
26	C537E	BUFFER STOP
27	A554	TRICKLE VENT
28a	C592	CARRIER
28b	ST838PPSS	Fixing Screw
28c	C589 / C590 / C591	BAR TILT RESTRICTOR
29		BALANCE
30		BALANCE
31		TOP SASH STOP (AT CILL)
32		RISER BLOCK
33		BOTTOM SASH STOP (AT HEAD)
34	C588	SASH STOP END CAP
35	C701 E	WOOLPILE 5.8 550 SF
36	C702 E	WOOLPILE 6.7 475 SF
37	C700 E	WOOLPILE 5.8 475 SF
38	C703 E	WOOLPILE 5.8 775 SF
39	C547W/E	SLIDE LATCH KEY
40	F456	No 10 x 5/8" Pozzi PAN S/T ,S/S screw
41	F202	No 10 x 1" Pozzi PAN S/T ,S/S screw
42	F144	No 8 x 3/4" Pozzi CSK S/T ,S/S screw
43	F303	No 8 x 1/2" Pozzi PAN S/T ,S/S screw
44	F38	No 6 x 1/2" Pozzi CSK S/T ,S/S screw
45	F502	No 6 x 3/8" Pozzi CSK S/T ,S/S screw
46	F201	No 10 x 1" Pozzi CSK S/T ,S/S screw
47	F198	No 8 x 3/8" Pozzi CSK S/T ,S/S screw
48	C548	FOAM PLUG

COLOUR OPTIONS AVAILABLE ARE KEYED .
W - WHITE, E - EBONY, S - SILVER

ITEMS NOT ILLUSTRATED :

49		HORN ASSEMBLY - RH
50		HORN ASSEMBLY - LH
51	C546W/E	TRAVEL RESTRICTOR KIT
52	C543	BALANCE FITTING TOOL
53	C544	SHACKLE
54	C527	KEY (FOR C526)



C538 - 20mm



C520 - 24mm

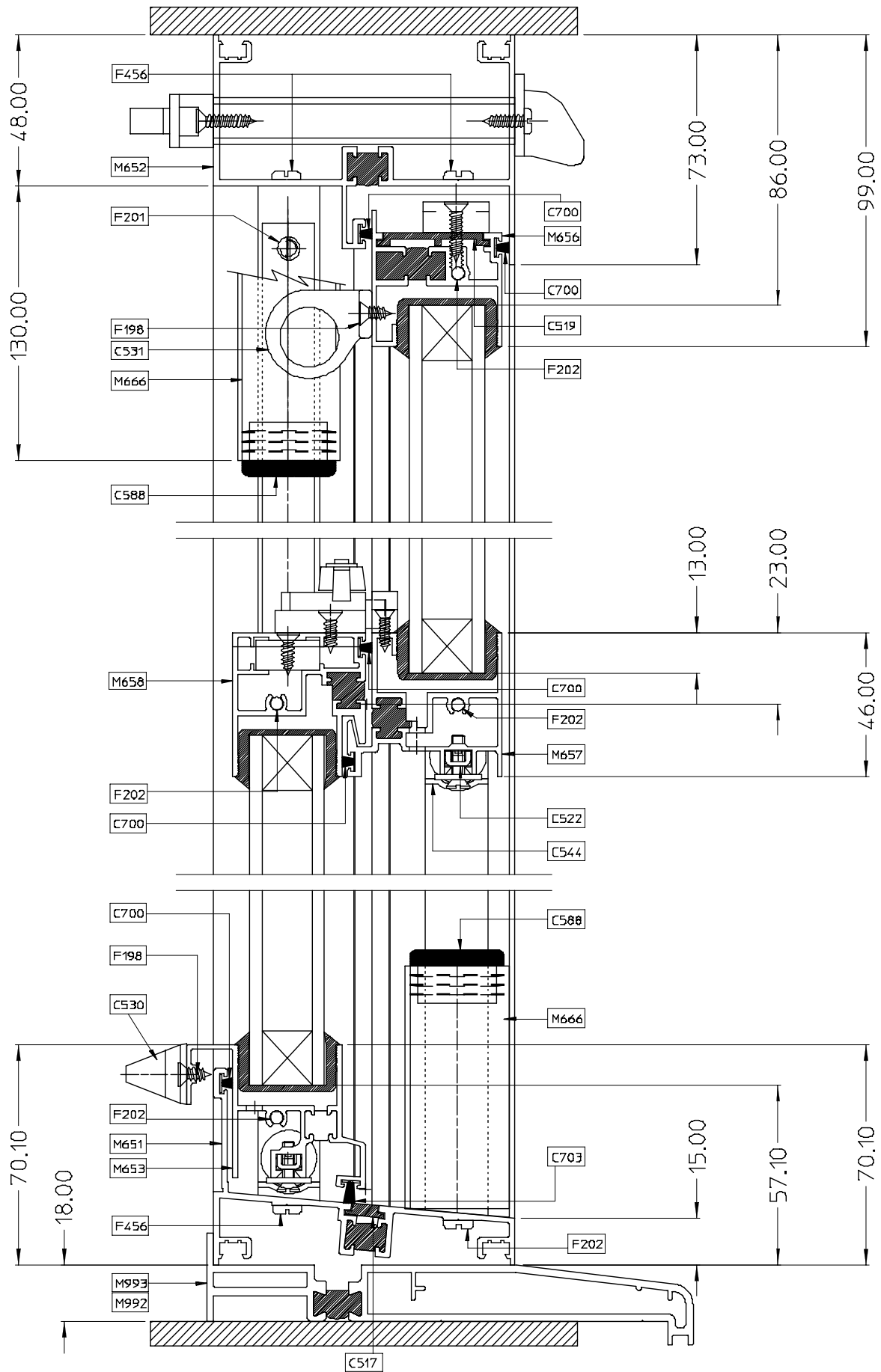

Fig. 2a. Key Sectional Views

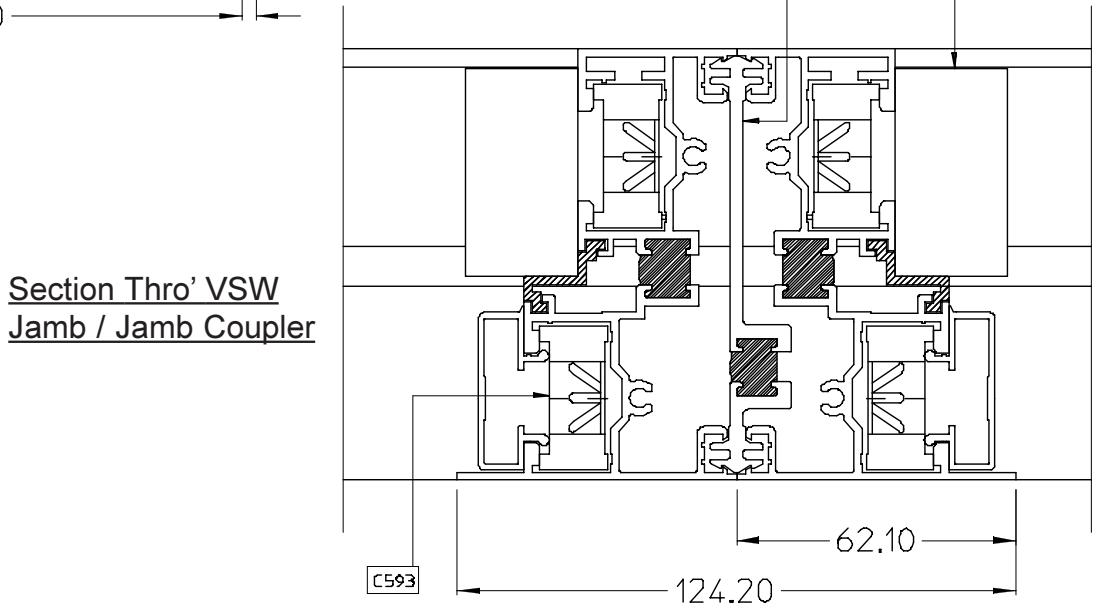
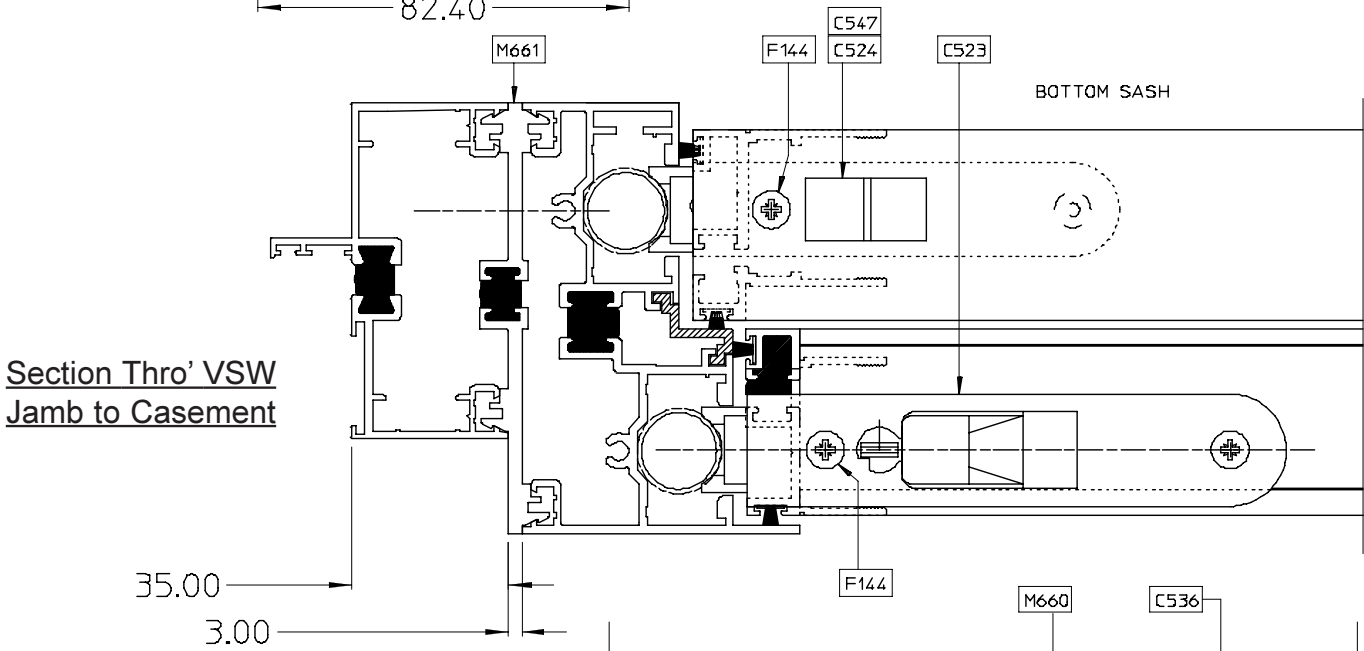
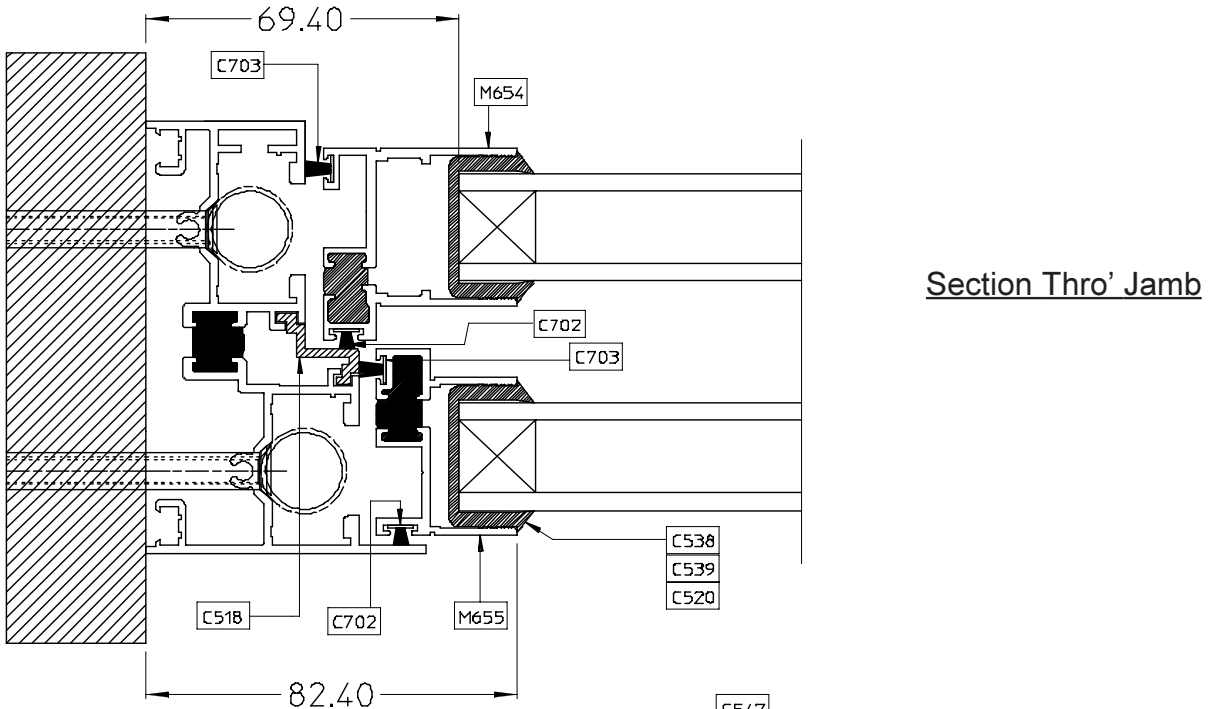
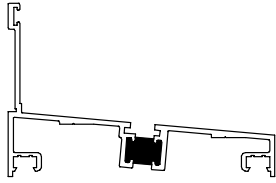

Fig. 2b. Key Sectional Views

A. 3. Identification

3.1 Extrusion Profiles



M651 - Cill

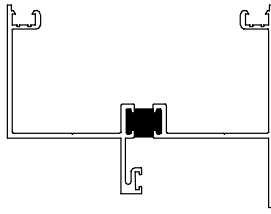

M662 - Head

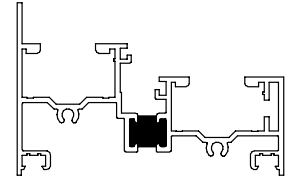

M652 - Jamb

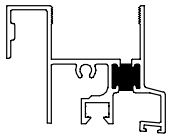

**M653 - Bottom Sash
Bottom Rail**

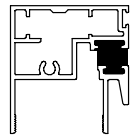

**M658 - Bottom Sash
Interlocker**

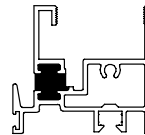

**M657 - Top Sash
Interlocker**

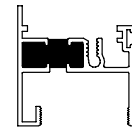

**M656 - Top Sash
Top Rail**

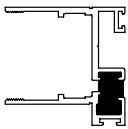

**M654 - Bottom Sash
Stile**

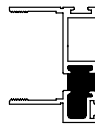

**M655 - Top Sash
Stile**

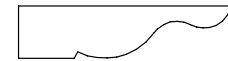

M665 - Horn

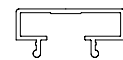

M666 - Sash Stop

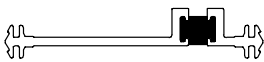

**A660 - Hidden Coupling
96 - 96mm Adaptor**



**A661 - 96 to 75mm
Adaptor**



M664 - Horn Bracket

3.2 Plastic Trim Profiles



C517 - Cill Infill

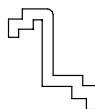

C518 - Jamb Infill

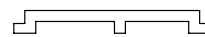

C519 - Top Rail Infill

A. 4. Hardware

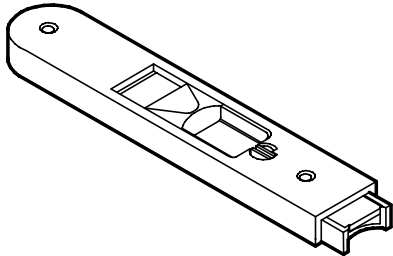

C523 Slide Catch - Top Sash
Fig. 4.1

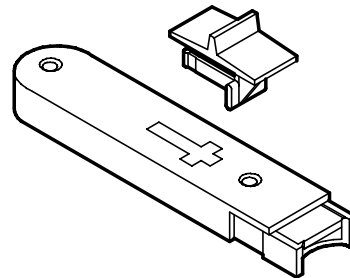

C547 Slide Catch Key
C524 Slide Catch - Bottom Sash
Fig. 4.2

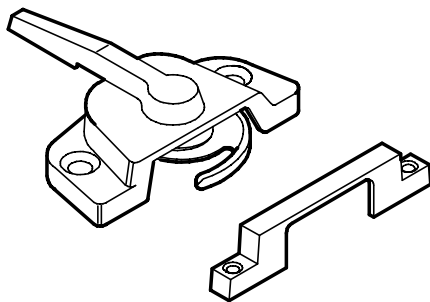

C525 Sash Lock - Standard
C528 Keeper Plate
Fig. 4.3

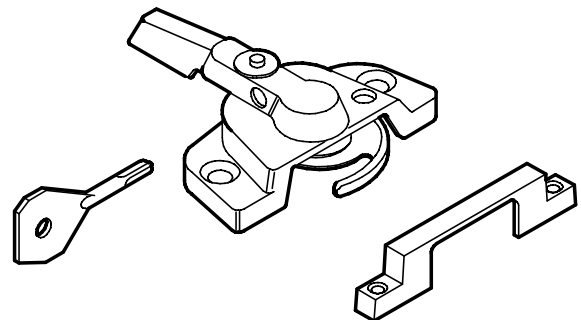

C526 Sash Lock - Lockable
C527 Key
C528 Keeper Plate
Fig. 4.4

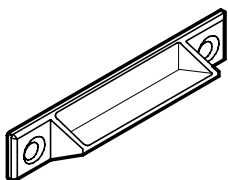

C530 Sash Lift Handle
Fig. 4.5

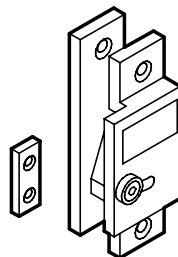

C546 Travel Restrictor Assembly
Fig. 4.7

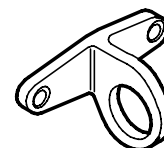

C531 Pole Ring
Fig. 4.8



C543 Balance Tensioning Tool
Fig. 5.1



Alumatilt Balance
Fig. 5.2

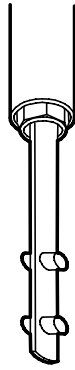

Ultralift Balance
Fig. 5.3



Torso Balance
Fig. 5.4

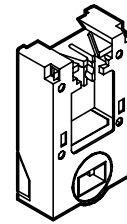

C593 Pivot Shoe
Fig. 5.5

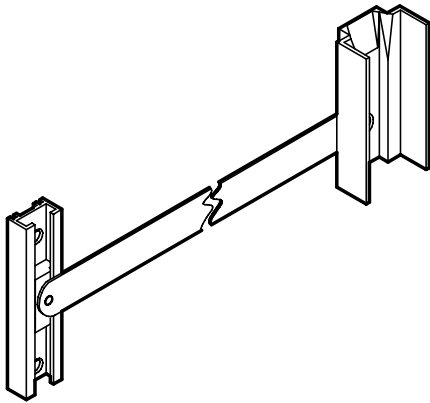

C589 / C590 / C591 Metal Stay
Fig. 5.7

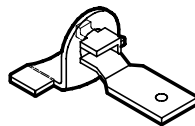

C544 Shackle
Fig. 5.8

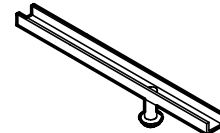

C522 Pivot Bar
Fig. 5.6



C595 Riser Block
Fig. 5.9

B. FORMULAE

B. 1. Glass Calculations

- Sapa will assume that, unless otherwise specified, the window will be equally split with the interlocker centre line at half the kit height.

i.e. $HT = HB = H/2$

NOTE : This will mean that the glass unit height will be different for each sash.

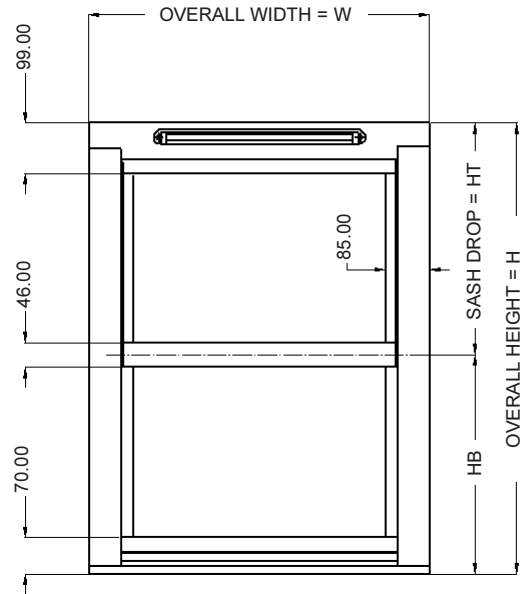

Otherwise ;	Width	Height
Top Sash Glass Unit	'W' - 139	'HT' - 96
Bottom Sash Glass Unit	'W' - 139	'HB' - 67

Formula for

$$\text{Equal Glass Height} = \frac{(H - 163)}{2}$$

Parameters :

Max recommended Width	=	1500	mm
Min Width (with Trickle Vent)	=	350	mm (430 mm)
Min Width with 2 Trickle Vents	=	900	mm
Max Height	=	2800	mm
Min Height (Equal / Equal Glass)	=	820	mm
Min Height (Equal / Equal S'Line)	=	850	mm
Min drop (Min Glass Height 328mm)	=	425	mm
Max drop (Max Glass Height 1335mm)	=	1430	mm
Max Sash Weight (Tilting Windows)	=	35	Kgs
Max Sash Weight (Non Tilting Windows)	=	40	Kgs

- The table below is the maximum glass unit area for combinations for 3 sizes. These are for double glazed units with both glass thickness the same. (i.e. 24mm = 4-16-4)

Areas shown are based on bottom sash with extrusion weight included.

(Top sash unit area is shown in brackets.) Glass weight taken as 2.56 Kg/m²/mm.

- For any other size/glazing combinations refer to Sapa Technical Department.

Thickness	4mm	5mm	6mm
4mm	1.44 M ² (1.46 M ²)		
5mm	1.28 M ² (1.31 M ²)	1.16 M ² (1.18 M ²)	
6mm	1.16 M ² (1.18 M ²)	1.06 M ² (1.08 M ²)	0.97 M ² (0.99 M ²)

B.2. Balance Matrix

Monarch Balance Selection
Thermal windows Ht. glass 2 x 4mm

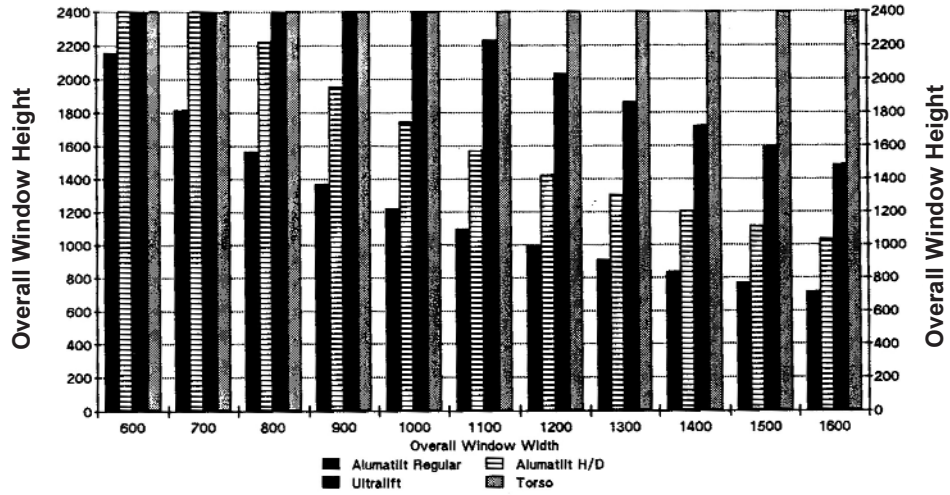

Thermal windows Ht. glass 2 x 5mm

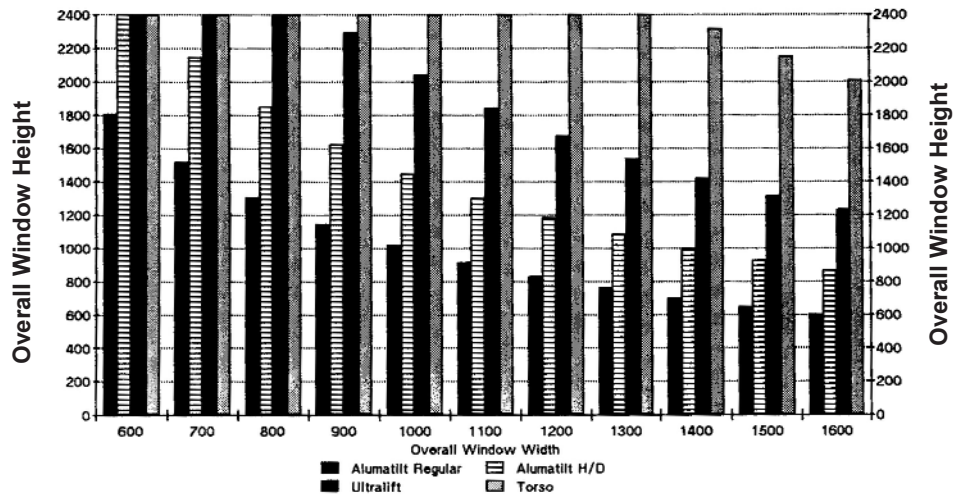

Thermal windows Ht. glass 2 x 6mm

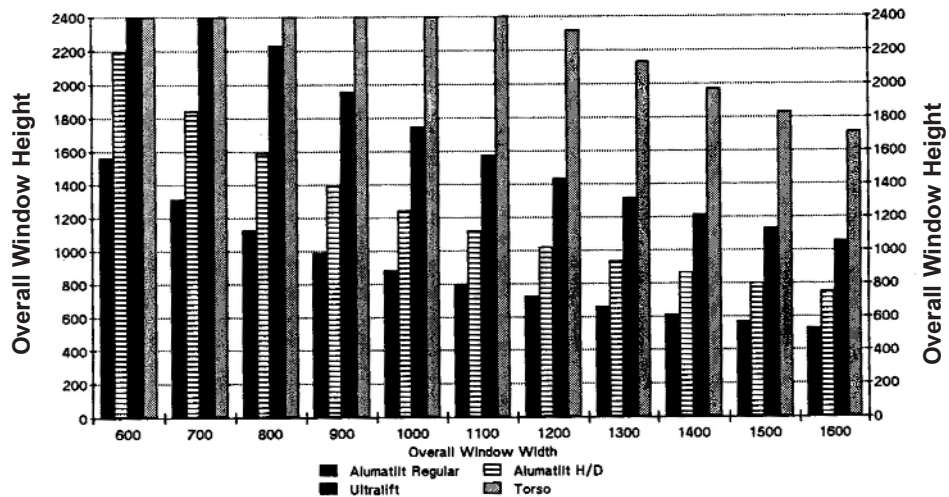

C. WORKSHOP PROCEDURES

C.1. Safety & Important Notes

- Please read this manual prior to any assembly.
- Always use the correct tools and equipment, especially when installing the sashes.

C.2. Tooling & Equipment

- C543 - Tension Tool :- For fitting all balances to the shoes and adjusting the Alumalift balances only. Ref. page D2 and D3.
- Sash Props :- When fitting the top sashes with shackles to the frame, suitable lengths of dowelling (Max Dia. 1/4" or 6mm) may be used to hold the pivot shoes away from the balances to simplify assembly. Ref. page D5.

C.3. Factory Sub-Assembly

3.1 Top Sash

- Standard kits should have the correct woolpile fitted within each component, it is advisable to check it has not fallen out. Top and bottom rail should have C700E fitted, with the vertical sash jambs having C703E and C702E. Refer to fig 8.

- The top rail should also have a plastic infill fitted (Z515).

- We recommend that all woolpile are suitably secured. Using a flat bladed screw driver and hammer, the woolpile pocket can be locally crushed inwards to secure the woolpile firmly.

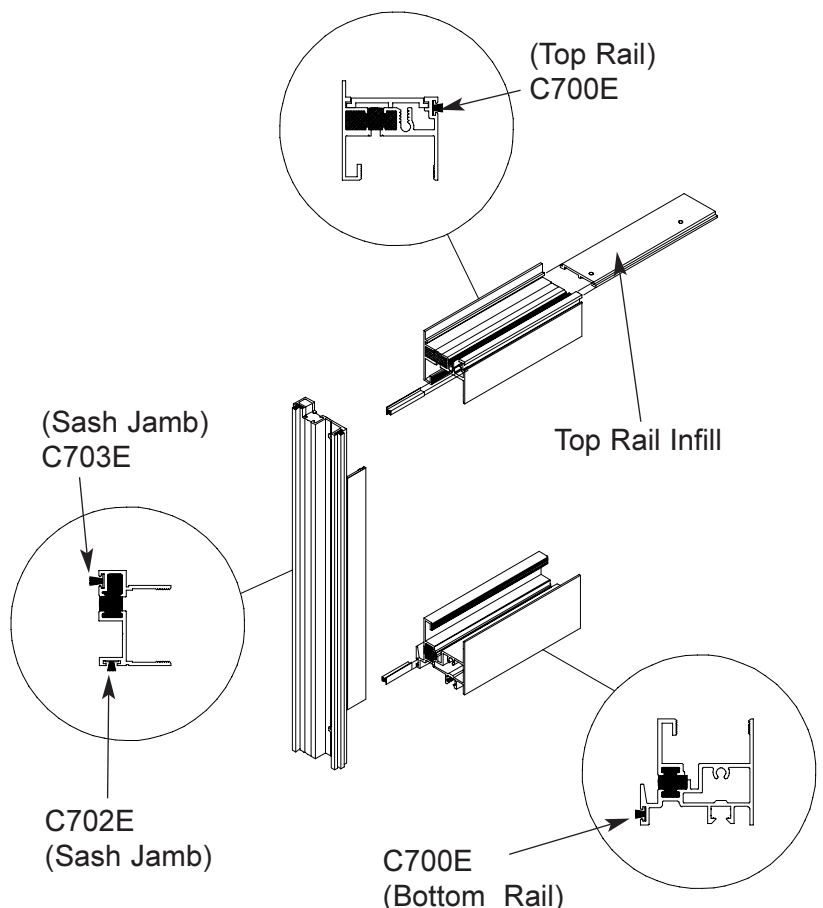

Fig. 8
Top Sash Assembly

- Fit the gasket around the glazing panel as follows :

Support the glass panel on two trestles that are narrower than the width of the panel. Select the correct glazing gasket and cut a length sufficient to wrap round all edges of the panel, plus an additional 100mm (4") for overlap and cutting. Cut one additional section of glazing gasket approximately 50mm(2") long for use as a slicing template.

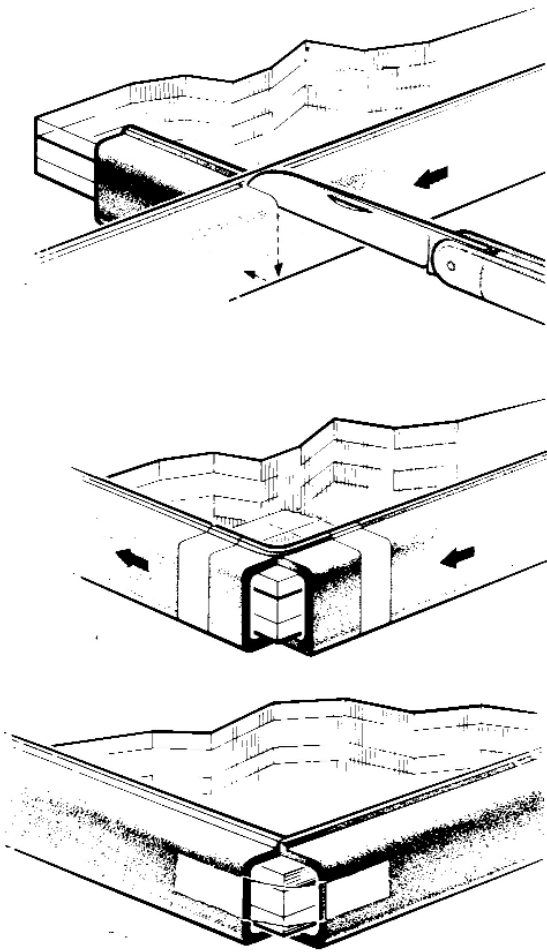

Fig. 9
Fitting Glazing Gasket

- Start approximately 12mm from the top right hand corner of the panel, wrap the channel of the glazing gasket along the edge of the glass and allow it to extend beyond the bottom corner of the panel. Place the slicing template on the adjacent edge of the glass, butting upto the gasket. Cut through the body of the gasket in line with the raised edge of the slicing template, but **DO NOT CUT THROUGH THE RAISED EDGE OF THE GASKET THAT IS BEING FITTED.**

- Bend the gasket around the bottom corner of the panel and hold it in position with adhesive tape.

- Continue wrapping the gasket along the edge of the panel and repeat the slicing process at each corner. When all the edges have been covered, use the already fitted gasket as the template for the final cut and hold the two ends in position by placing adhesive tape along the exposed back of the gasket ends.

- When using patterned glass, it is recommended that the patterned glass side is glazed to the inside to ensure maximum sealing of glass to gasket on the outside.

- Refer to 'Extrusion', section 'A3' for component identification.

- Fit the top and bottom rails onto the panel, using a sash cramp if needed to position the rails fully onto the gasket.

- Apply clear or coloured matched silicone sealant to the mating surfaces of rails and stiles.

- Pick the correct stiles from the kit; the top sash stiles are square cut at each end.

- Place the stiles in position, line up the fixing holes with screw ports, and screw fix them to the rails using No.10 x 1" Pozi Pan Hd screws (F202).

- The top sash slide latches (C523), fitch catch keep(s) and pole hook (if specified) may be fitted now. Alternatively, to avoid any possibility of transit damage, the keep and hook can be fitted on site.

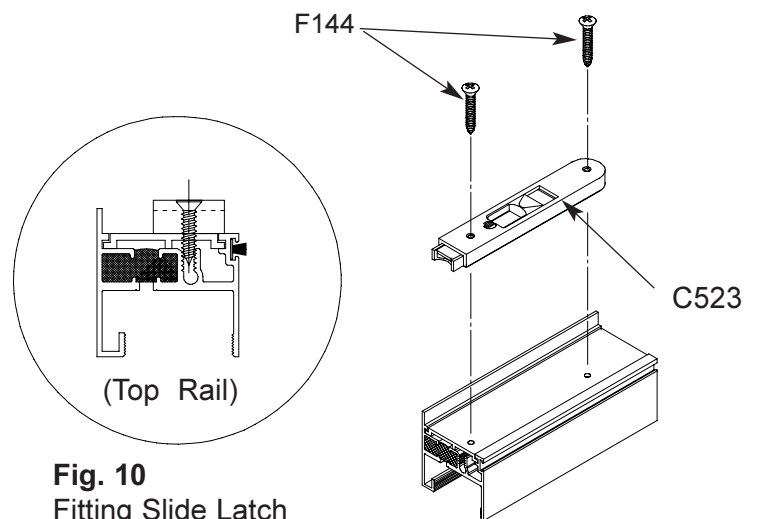

Fig. 10
Fitting Slide Latch

Top Sash Slide Latches - Using the pre-drilled location holes, fix the latches (C523) in position with No.8 x 3/4" Pozi Csk screws (F144).

Fitch Catch Keeps - Place the fitch catch keep (C528) onto the bottom (interlocking) rail, so that the inner edge is flush with the rail edge. Using a Stanley knife or similar blade, remove only enough gasket to allow the keep(s) to locate correctly. Fix the keep(s) using No.6 x 1/2" Pozi Csk screws (F38). (See Fig.11)

Pole Hook - Secure the Pole Hook (C531) in position with No.8 x 3/4" Pozi Csk screws (F198).

3.2 Bottom Sash

Assemble the sash frame in the same way as the top sash.

Bottom Sash Slide Latches - Slide the latches (C524), less operating catches, into the (interlocking) rail and secure with No.8 x 3/4" Pozi Csk screws (F144) through the prepared holes (Fig.12).

Tilt/Slide Model Only. Insert the operating catch keys through the cruciform slots in the rails and push them towards the rail centre to engage them into the latches.(See Fig.12)

The Fitch catches and lift handles may be fitted now or on site.

Fitch catches - Place the catch(es)(C525/6) onto the top rail and fix with No.6 x 1/2" Pozi Csk screws (F38).

Lift Handles - Place the lift handles (C530) in position on the bottom rail and fix using No.8 x 3/8" Pozi Csk screws (F198), thro' the pre-drilled holes. **Do not overtighten !**

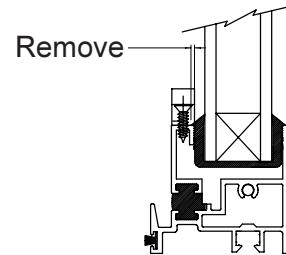
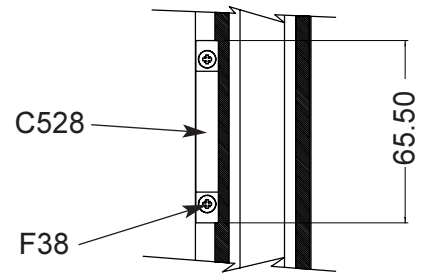

Fig.11
Fitch Catch Keep Positioning

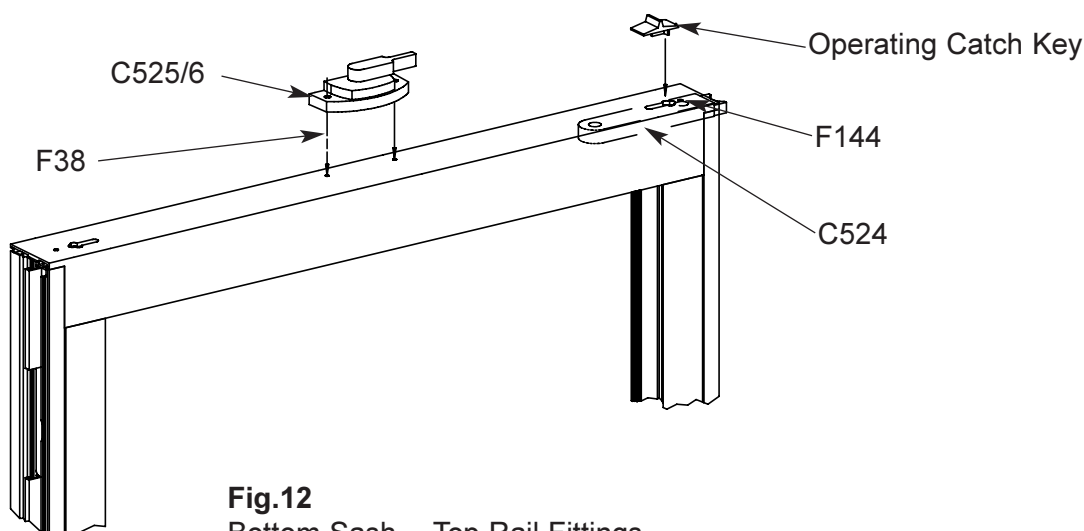

Fig.12
Bottom Sash - Top Rail Fittings

3.3 Outer Frame Assembly

- Check that the head and cill have correct woolpile fitted (C700) prior to any assembling.
- Fit the jamb and cill infills into their corresponding frame sections making sure that both are securely fixed with silicone sealant. Please note that the cill infill should be cut 20mm short of the overall cill length. (See Fig 13)
- Apply clear or colour matched silicone sealant to the mating surfaces and fix the head and cill to their corresponding jambs using the No.10 x 5/8" Pozi Pan Hd screws provided (F456).

- Where the cill infill has been cut 10mm short at each end fill the remaining gaps/channel liberally with silicone sealant to prevent water tracking out into the brickwork. Sealant should also be applied liberally around enclosed pocket as shown (Fig. 13) at both head and cill.

- Fit flipper seal (A3004) to outer frame if required.

Silicone sealant, liberally around pocket and in channel.

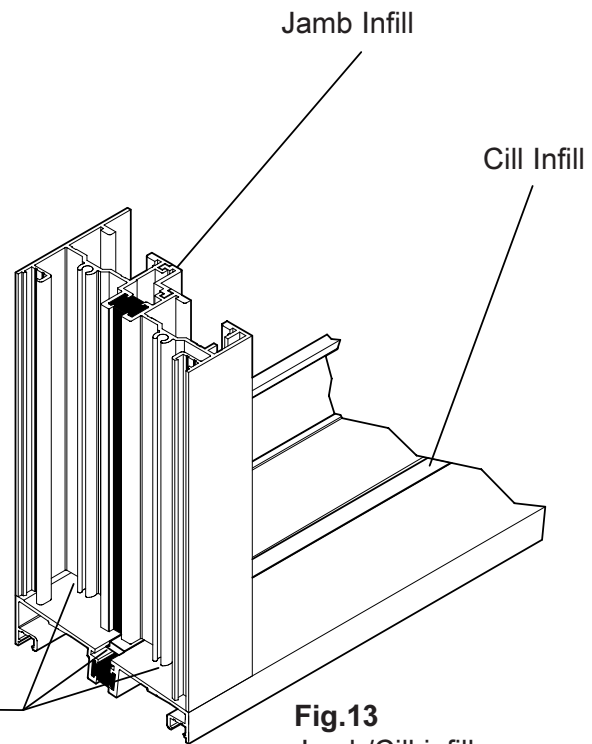

Fig.13
Jamb/Cill infill

NOTE : Spring balances may be fitted to jambs before assembling the frames.

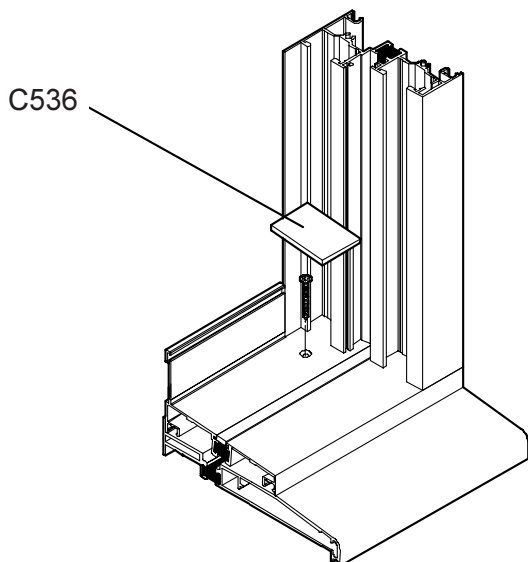

Fig. 14 - Fitting Frame to Add on cill

- If the frame is to be installed onto a Monaframe cill (A993 or A994), place the VSW frame onto the cill against the upstand and clamp them together. Before clamping, run a small bead of silicone sealant along cill upstand in corner. Drill a 4.5mm dia clearance hole into the cill about the corner where it is at a position to be hidden by the foam buffer pad (C536), and countersink to 7.5mm dia. Drill thro' this, a 3.5mm dia. tapping hole into the add on cill, thro' both webs of the cill. Fix the frame and cill using No.8 x 1 1/4" Pozi CSK Hd screws in both corners. For larger windows a central fixing may be required. (See Fig 14)

3.3.1 Trickle Vent - if Selected

- Slide the sleeves into the pre-prepared slots, making sure they are correctly positioned to miss the vent mechanism.
- Fit the hood, vent and screw cover plugs. Check the vent works smoothly and does not foul the sleeves.
- For optimum performance seal the vent to frame with clear or colour matched silicone sealant.
- NOTE : The minimum width of VSW for use with the standard trickle vent is 430mm giving 4000mm² of clear ventilation. The minimum width of VSW for use with two standard trickle vent is 900mm giving 8000mm² of clear ventilation.
- See page D8 for pack details.

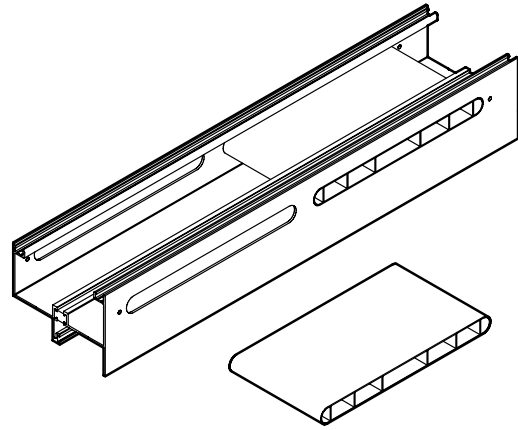

Fig.15
Trickle Vent

3.4 Combinations

- See SECTION D.7 page D12.

3.5 Transit Precautions

- Make sure the correct balances and accessories are allotted to each window.
- Apply suitable protective material to all frames ready for transporting to site.
- Brace outer frame to prevent distortion.

D. INSTALLATION

D. 1. Installing the outer frame

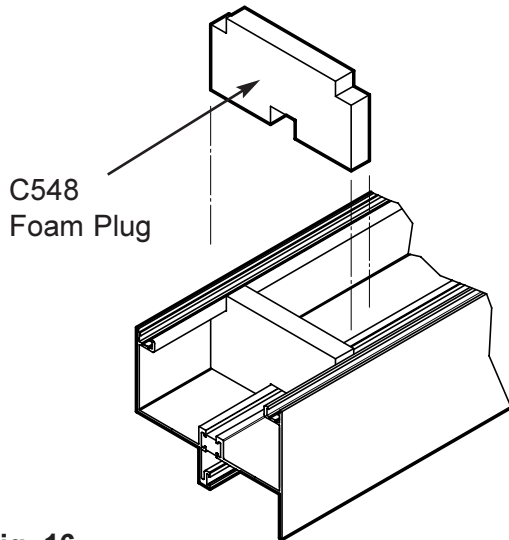

Fig. 16
Foam Plugs

- Fit the 2 buffer stops (C537) into the outer channel of the head using No.10 x 5/8" Pozi PH screw (F456). (See Fig 17).

- Place the outer frame into the aperture, packing it to ensure that it is square, level and vertical.

Either,

- Fix thro' the outer jambs at a maximum of 600 centres in both channels, with suitable heavy duty fixings (See Fig 18).

or

- By using Monarch Fixing lugs A557 with suitable fixings if preferred.

- Fit the foam plugs (C548) to each end of the head and silicone seal them in place.

- If the window is to sit on a Monaframe cill, reshape a standard cill end plug and fit approximately 15mm from each end of the cill. Fix the main frame down thro' its cill into the add-on cill using No.8 x 1 1/4" Pozi CSK screws as per page C4.

- Liberally fill around the end plug with silicone sealant to prevent any water tracking thro' into brickwork.

- Check trickle vent is fitted and working, refer to page C5 if fitting instructions required.

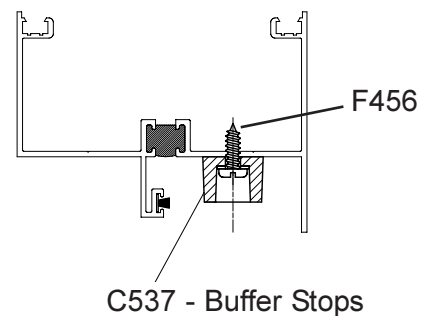

Fig. 17
Fitting Buffer stops

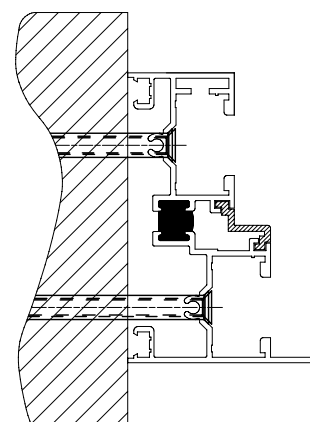

Fig. 18

Fig. 18
Frame Fixing Positions

D.2. Fitting the Balances & Restrictor Stays

- Fit the balance pivot shoes, by dropping them down the jambs through the slotted openings onto the frame cill. (Fig.19)

- Select the correct balances for each sash (on equal split windows the longer balances are for the bottom sash, on the inner jamb channel). Using the pre-drilled pilot holes, fix the balances into the jambs using No.10 x 1" Pozi C'sk screws (F201). (Fig.21)
Do not overtighten the fixing screw !

- For un-equal splits, where the top sash is larger than the bottom sash, re-fit the balance down the jamb so that the tube end is below the interlocker.

- Please note, all Ultralift and Torso balances are pre-tensioned to suit individual windows, for details of Alumatilt balances refer to page D3.

- Fit the metal stays into the jambs via the slotted openings, making sure the glider orientation is correct. The tapered inner edge should be positioned facing up, this is to help the glider ride over the end of the balance. (Fig. 20)

- With the metal stay arms above them, lift the pivot shoes and arms together up the jambs and using special tool C543, engage the balances into the pivot shoes.

Refer to the Alumatilt section for further details on fitting.
(Fig.22)

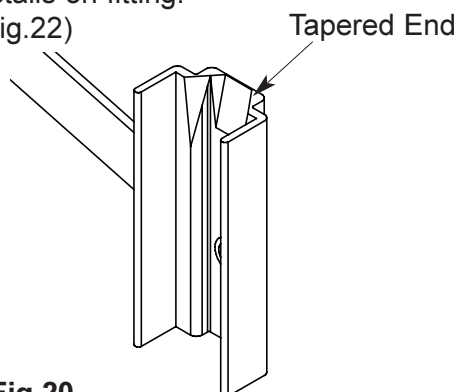

Fig.20
View on Glider

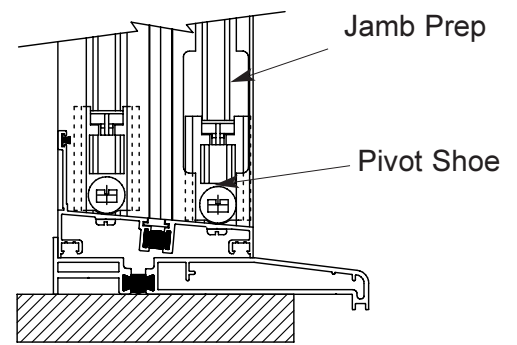

Fig. 19
Locating Pivot Shoes

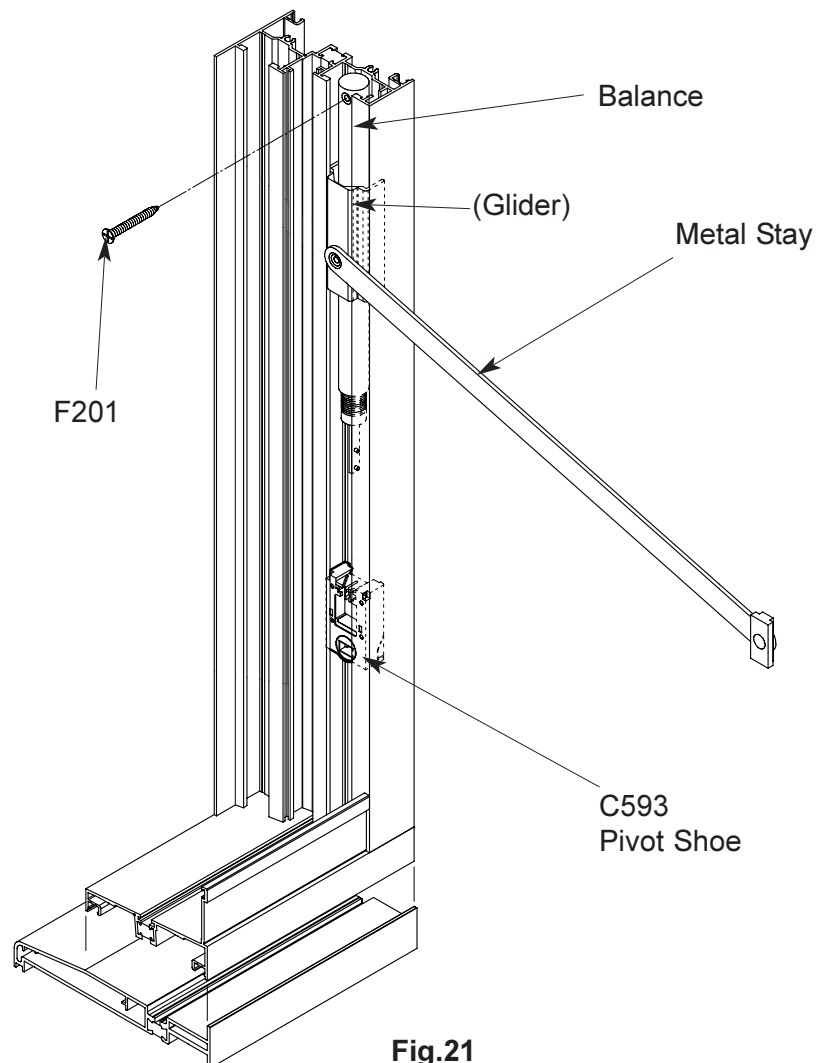

Fig.21
Fitting the Balances (Caldwell)

NOTES:

If either sash is specified as a fixed light, balances, shoes etc. will not be supplied for that sash. Longer sash stops will be supplied to suit the corresponding sash although stops will require additional cut down.

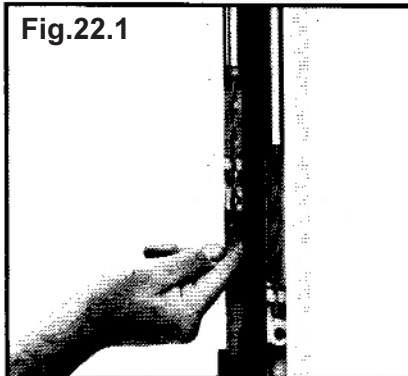

Fig.22.1

On Alum tilt balances, before engaging the springs, wind them the correct number of turns as shown on the paperwork supplied with the balances.

How to fit Alum tilt Balances ;

- After attaching balance to the frame and inserting the shoe into the jamb, lock the shoe into position to accept the comfortable engagement of the pivot bars when the sash is offered to the frame.

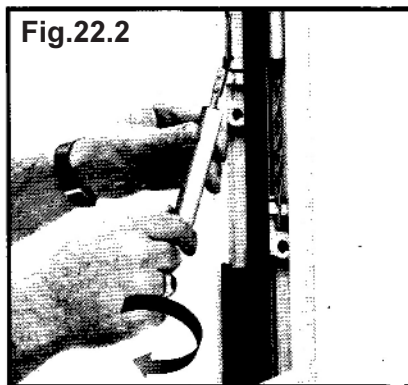

Fig.22.2

DO NOT OVERTIGHTEN SCREW AS THIS WILL DEFORM THE TOP OF THE BALANCE.

- If spiral rod is more than 2" out of the sash, push rod in with light finger pressure. Allow rod to rotate freely. (Fig.22.1)

- To apply tension, lock tensioning tool around the lower pin in the rod. **ROTATE TOOL CLOCKWISE** for the required number of turns (established from the tensioning chart - page D4). Allow rod to retract fully and latch top cross pin into the pivot shoe slot (Figs. 22.2 & 22.3).

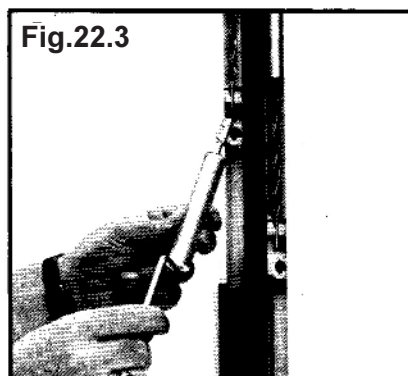

Fig.22.3

- To remove tension, push sash to its upper most position. Engage lower cross pin in rod with tool and unlatch rod. Pull down and remove rod from slot and reduce tension by rotating anti-clockwise.

FOR BEST COUNTER BALANCING ACTION, APPLY EQUAL TENSION TO BOTH BALANCES.

Caution

- To prevent balances from 'un-winding' and losing tension, always tension with sash in upper most position.
- Never engage the spiral rod with the tensioning tool, if the spiral rod is sticking out more than 2" of the balances.
- Check and be sure the Spiral rod is not bent in handling or tensioning.
- Tension for a specific weight of sash. **DO NOT OVERTENSION !.** (Refer to chart.)
- Be sure that the top pin is securely latched in pivot shoe.

IMPORTANT : Once the balances are fitted, fit the correct sash stops - see relevant section. This is to prevent accidental damaging to the mechanism.

D.3. Installing the Upper Sash

- There are several methods of installing the sashes, these will depend on each unique installation scenario. Although the method shown below is only a guide, the order of fitting sashes is critical to the final operation.

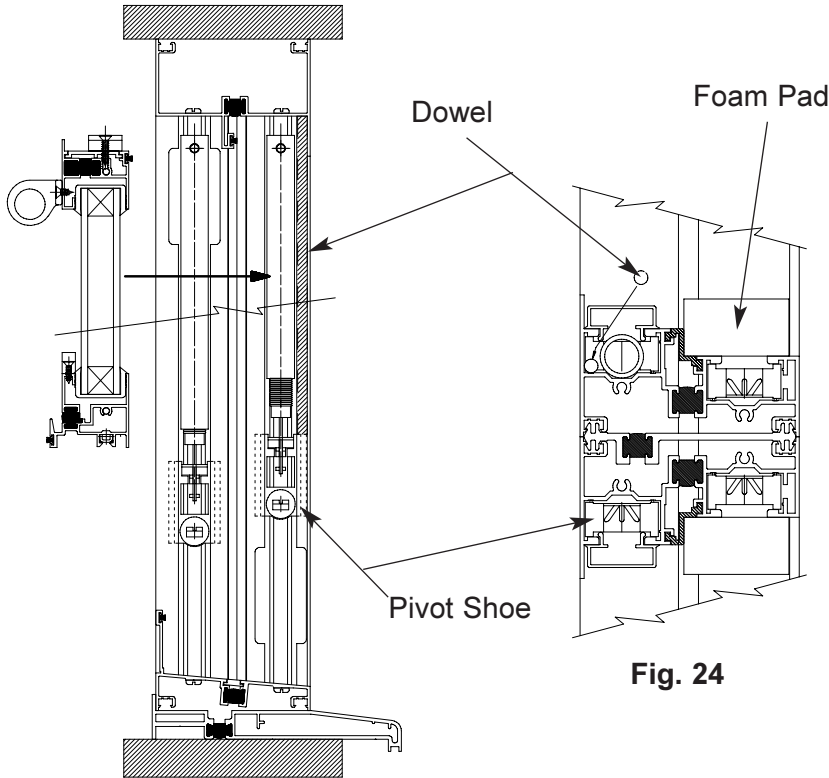

Fig. 23
Positioning Pivot Shoes

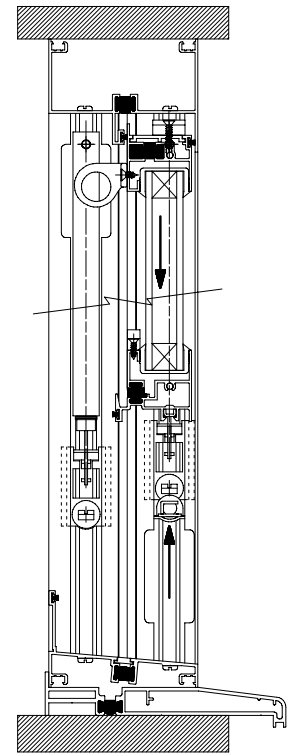

Fig. 25
Aligning Sash With Pivot Shoes

- With the balances attached, pull both pivot shoes down approximately 100mm and using dowelling or similar stays, prop them securely in this position.

(See Figs 23 & 24)

Please note, metal stay has been omitted for clarity only. It must be fitted into the jamb prior to sash installation.

- Insert the pivot bars into the bottom rail of the top sash, with the screw hole nearest the centre and the legs pointing towards the top (Fig 26a).

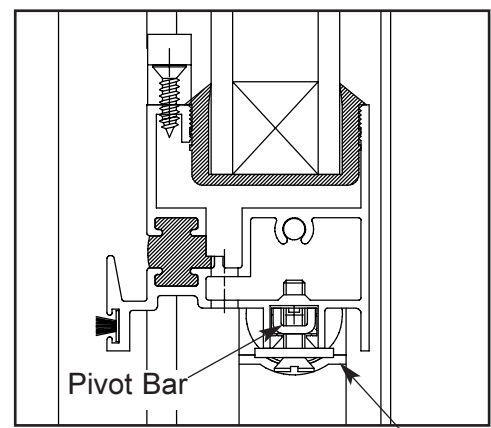

Fig. 26a Shackle

- Lift the upper sash into position in the outer jamb channel, making sure the slide latches are withdrawn when passing the jamb infills; release the latches so the sash is retained in the jamb.

Note : Shackles must be fitted on all sashes on all models.

- Gently lower the sash down until the pivot bars are lined up with the slots in the shoes. Offer a shackle up to the underside of the shoe and sash, then push the pivot bar through the shackle into the shoe.

Secure the shackle to the pivot bar using the M4 x 16 Csk machine screw. Repeat procedure for the other side (See Fig. 25 & 26b).

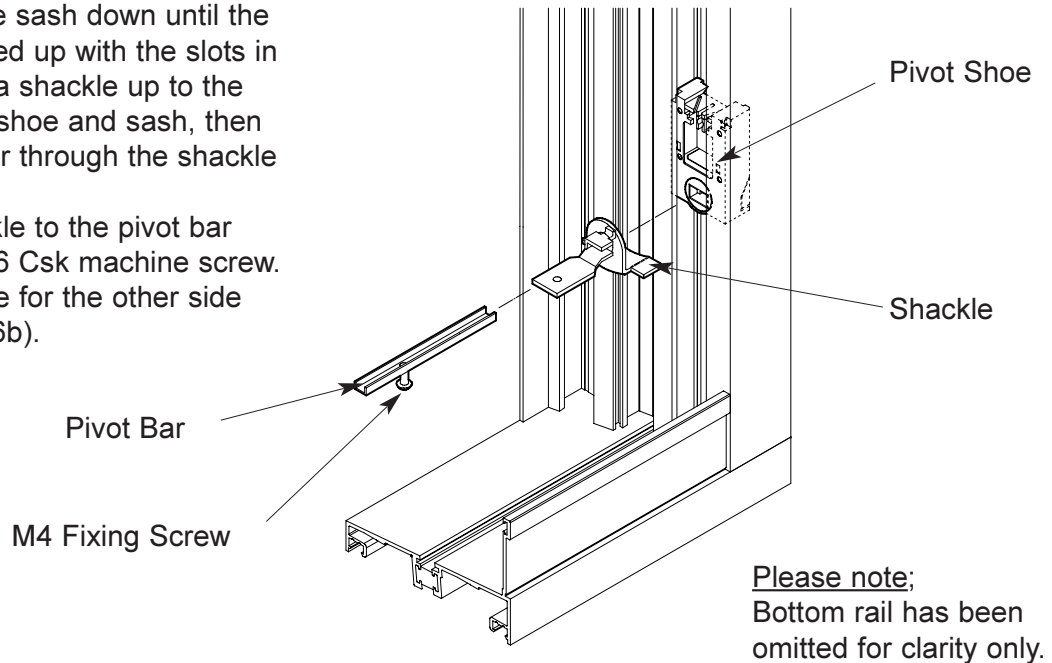

- Lower the sash and remove dowel prop.

Fig. 26b

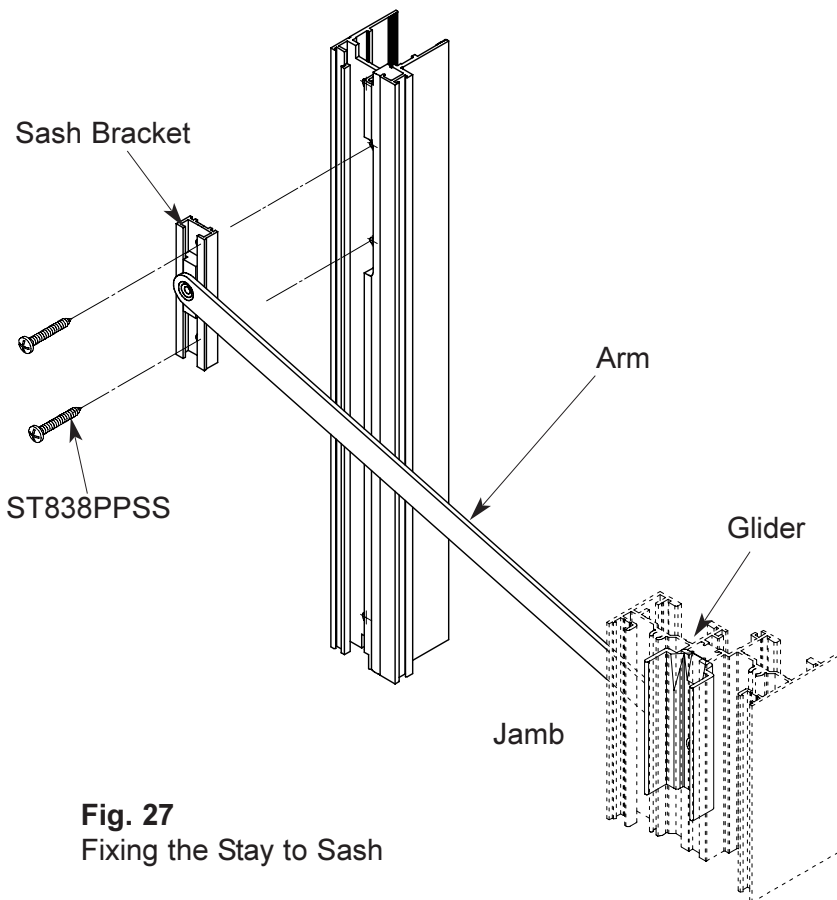

Fig. 27
Fixing the Stay to Sash

- The metal stay should now be fitted to the top sash. Release the top latches and drop the sash down and inwards to a suitable angle within the building. With the stay arm fitted into the sash bracket, fix the bracket to the sash with 2 off, No.8 x 3/8 Pozi Pan Hd screws (ST838PPSS). The glider, within the jamb, should slide up and down freely until the arm locks itself out.

- Repeat this procedure for the opposite side. Please note that the metal stays are not handed.

- Check that the operation of the sash is smooth. This should be for both the vertical movement and tilting action.

Warning - Fit sash stops prior to testing full vertical movement !

Slide Models Only

- To prevent the top sash latches being accidentally withdrawn causing the sash to fall in, turn the slide locks through 90° with a small, flat blade screwdriver. (Fig. 28)

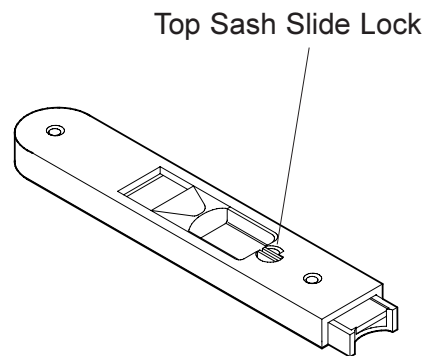

Fig. 28 - Locking Top Sash Slide Latch

D.4. Installing the Lower Sash

- Repeat the same procedure for the lower sash as per the upper sash.

- Check that the operation of the sash is smooth. This should be for both the vertical movement and tilting action.

Warning - Fit sash stops prior to testing full vertical movement !

D.5. Fitting the Sash Stops

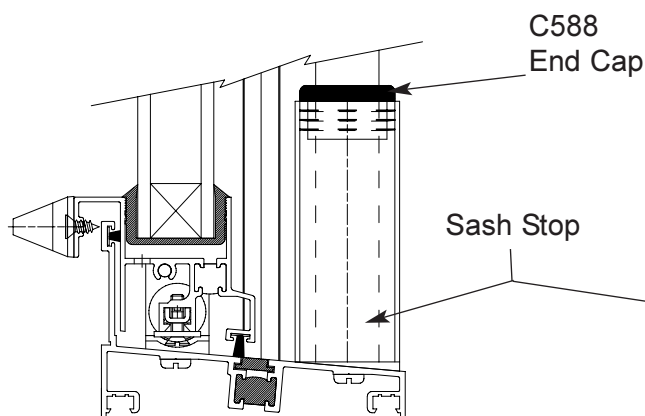

Fig.29. Fitting the sash stops

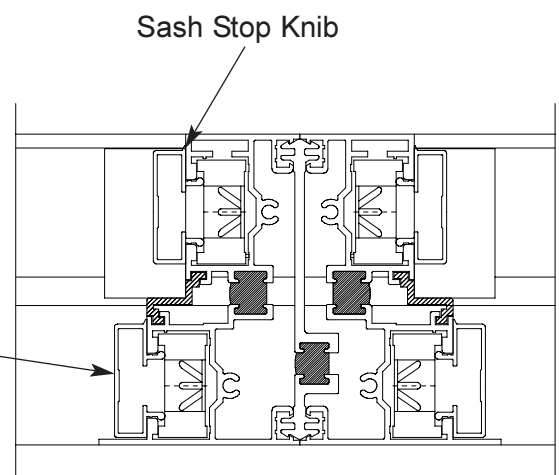

Fig.30. Sealing the sash stops

- Select the correct stops, for equal split windows the top sash stops are 220mm long and fitted at the cill. The bottom sash stops are 130mm long and are fitted at the head. Where unequal splits are required, for every 1mm above standard centre position, top sash stop increases in length by 2mm. Likewise, for every 1mm below the standard centre point, the bottom sash stop increases by 2mm.

- Before fitting the end caps into the sash stops (C588), check handing is correct. The sash stops knib should always be directed to the inside of the window. See Fig 30.

- Apply a thin bead of silicone sealant to their locating flanges, then clip them into place in their corresponding jambs.

NOTE :

The sash stops may need to be taped in place while the silicone cures.

WARNING :

IF SASH STOPS ARE NOT FITTED AS SUPPLIED, THE BALANCES WILL FAIL.

D.6. Fitting the Riser Block

- Although supplied as part of the kit, the riser block is an optional item where customers wish to reduce the horizontal movement of the sashes. These blocks can be fitted to vertical members on both sashes, as per the diagram shown below, for both tilting and non-tilting models. They can be either fitted before installation or retro fitted after on site.

- The Ø4.80 fixing holes should be positioned above any tilting preparations to avoid fouling with stays, a suitable adhesive should be applied to the riser block, before it is 'push fitted' into place.

Ø4.80 x 5mm Deep

C595

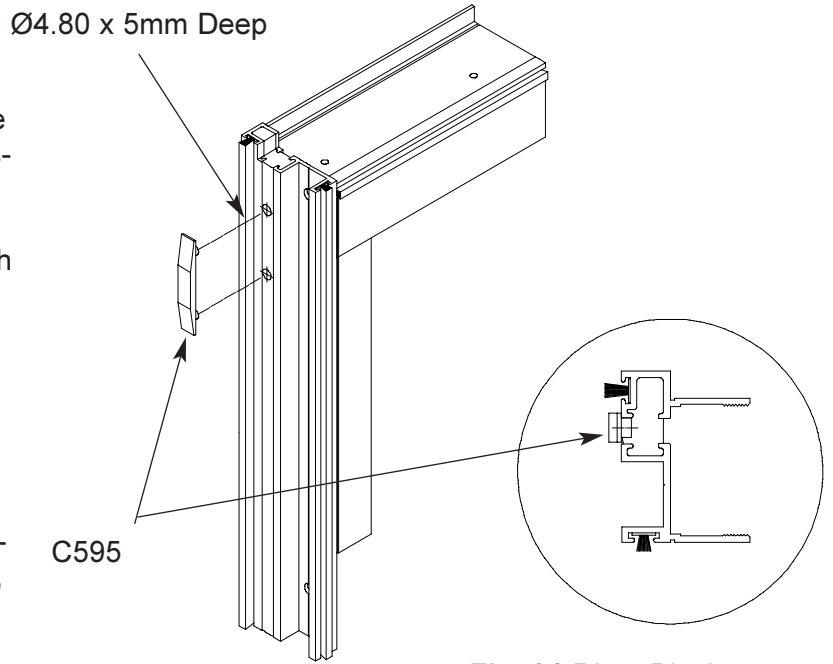

Fig. 31 Riser Block

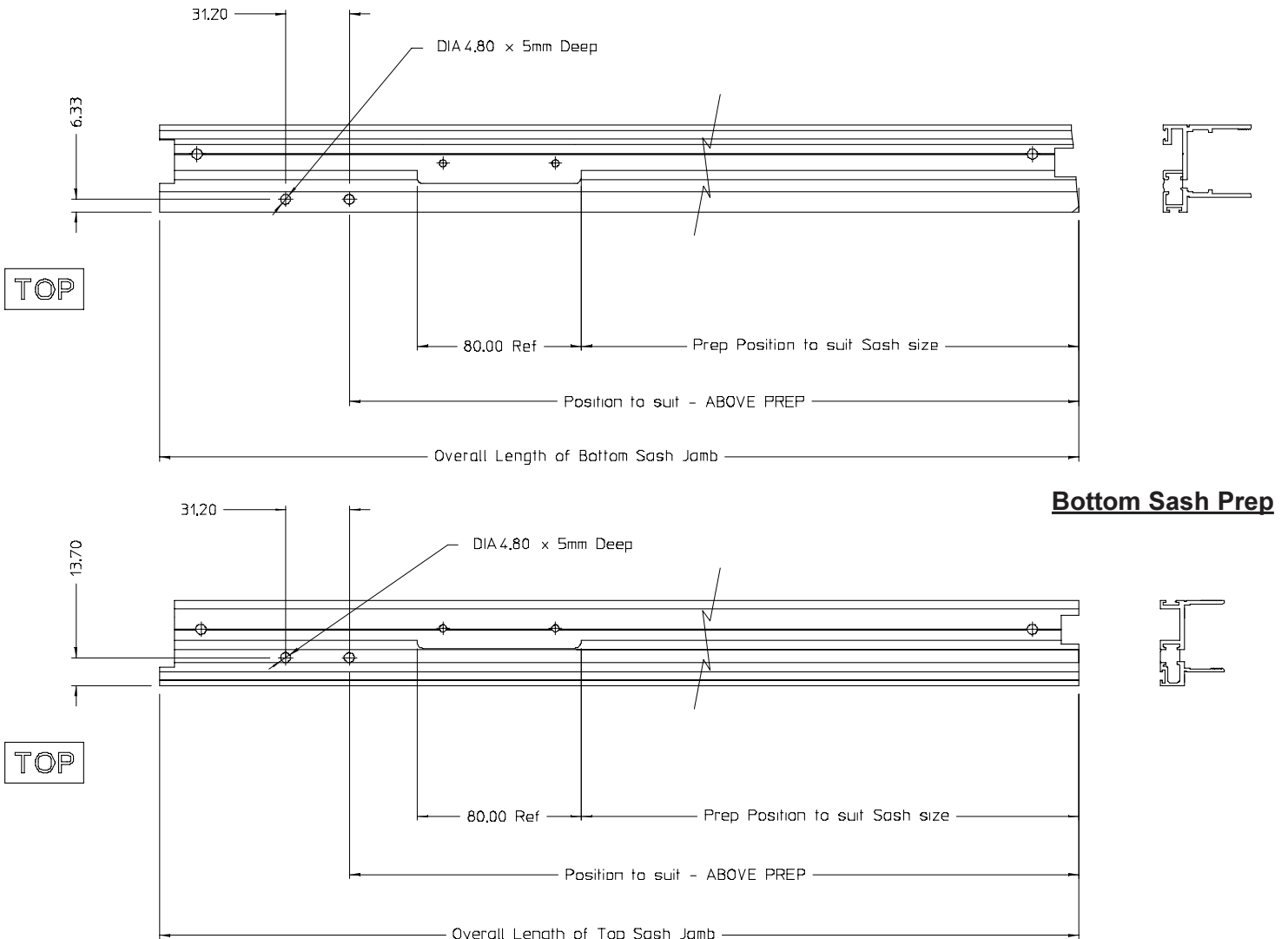

Fig. 32 Riser Block Prep

Bottom Sash Prep

Top Sash Prep

- Fit the self adhesive foam pads (C536) to the cill. (See fig. 14)

D.7. Accessories

7.1 Additional Hardware Packs

Standard packs available are ;

- A552 W/E - Fitch Catch Pack (Locking)
(Consists of 1 off - Catch, Key and Keep)
- A553 W/E - Fitch Catch Pack (Non Locking)
(Consists of 1 off - Catch and Keep)
- A554 W/E/BP - Trickle Vent Pack (Incl. Fixings)
- A555 W/E - Lift Handle Pack
(Consists of 2 off - Handles and fixings)
- A556 W/E - Pole Ring Pack
(Consists of 1 off - Pole Ring and fixings)

7.2 Fixing Lugs (A557)

For an additional method of fixing the frames on site, suitable fixing lugs are available in packs of 100. (A557) Fixing screws are not included.

The lugs are galvanized steel and can be fitted into the head or jambs by clipping between the Moniframe legs. There are 3 holes, Ø7.00 for suitable fixing points.

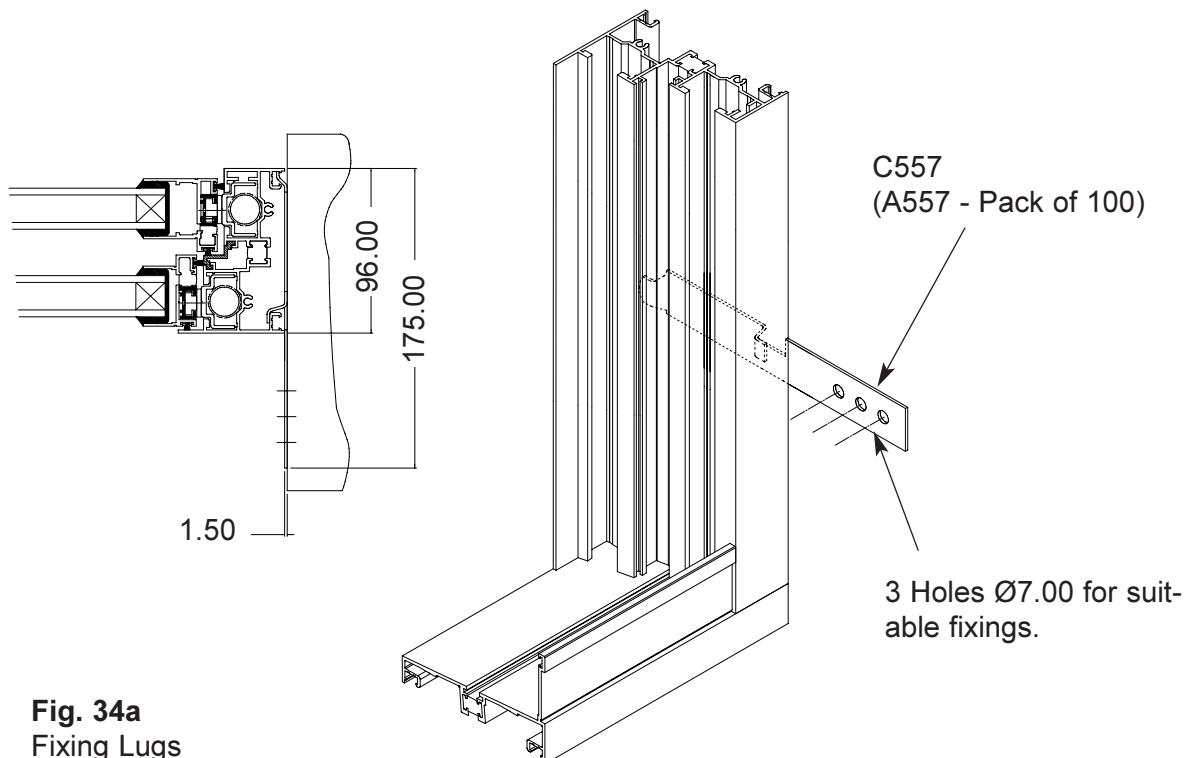

Fig. 34a
Fixing Lugs

7.3 Travel Restrictor Pack (C546 W/E)

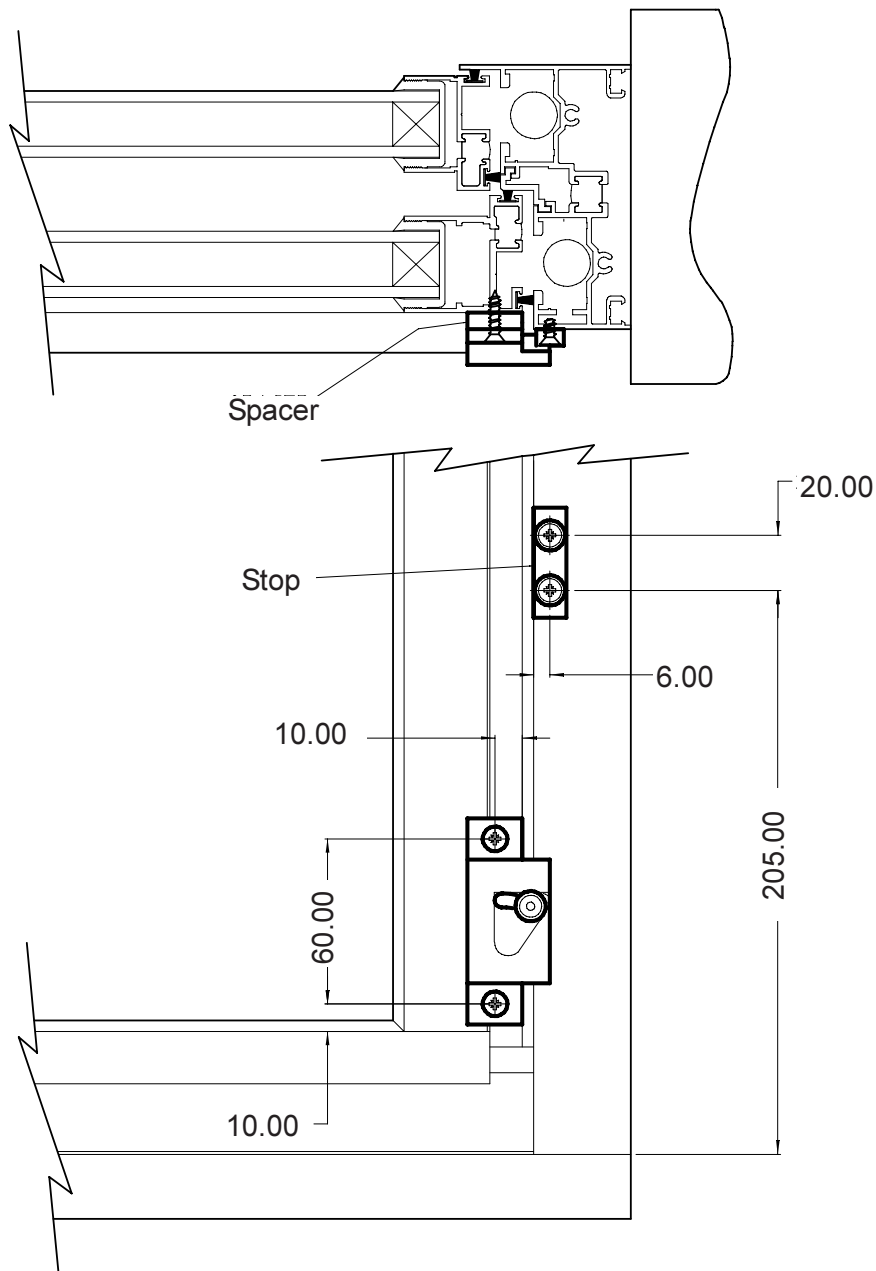

Fig. 34b - Fitting Travel Restrictors

- A pair of spring loaded travel restrictors (C546) may be fitted to the bottom sash as shown above.

- The restrictor bodies should be positioned just above the bottom rail and, using the restrictors as their own templates, mark and carefully drill 3.5mm holes for the No.8 x 3/4" Pozi CSK fixing screws (F144). Secure each restrictor with spacer block firmly in place.

- Choose the opening limit desired and fix the stop blocks using 2 off - No.8 x 3/8" Pozi CSK screws (F198), to the jambs as shown. The dimension given above is only for example where 100mm of movement is required.

7.4 Horn Accessory Kit (A572 W/BP)

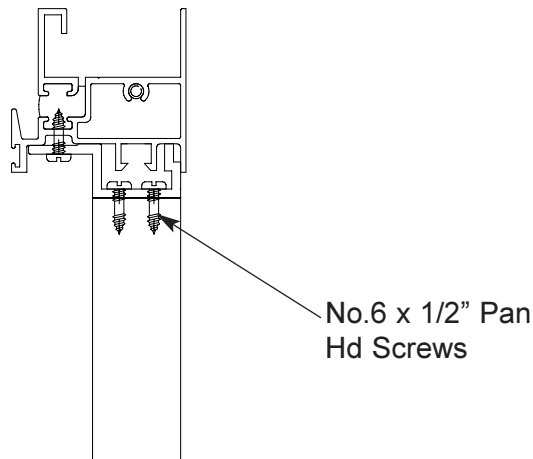

Fig.35
Horn fittings

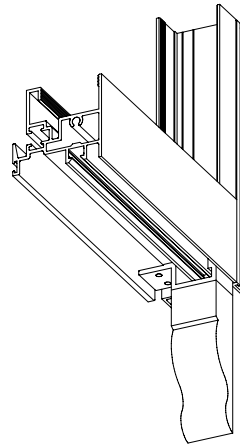

Fig.36
Right Hand Assembly

- A pair of handed sash horns (A572) may be supplied with the kit or alternatively, retrofitted after installation. The horns are fitted to the bottom rail of the top sash as shown above (Fig.35).

- If ordered with the window, the rail will have the attachment screw holes prepared ready for installation during assembly. This should ideally be carried out after the top sash has been assembled into the outer frame. Tilt the sash inwards thro' 90 degrees, support then secure the horns with the supplied No.6 x 1/2" Slotted Pan Hd fixing screws (F507).

Note : The horn assemblies are handed, flat side faces towards the frame jamb.

- Carefully close, open and close the vent to check that the horns do not foul the outer jambs.

- In the unlikely event of horns being retrofitted to an installed window, instruction leaflet C568 which is supplied with the horns should be read carefully.

Safety Note

Where horns are fitted to windows above ground level, extra care must be taken as assembly may require the fitter to position themselves into an awkward external fitting position !

7.5 Glazing Gasket

- Gasket is available in Black, 25 metre coils ;

- C540 - 4mm Single Glazed Gasket
- C541 - 6mm Single Glazed Gasket
- C538 - 20mm Double Glazed Gasket
- C520 - 24mm Double Glazed Gasket
- C539 - 28mm Double Glazed Gasket

D.8. Installing Combinations

8.1 Coupling Sliders together (Fig.37)

- Use hidden coupling mullion A660 to link the frames. Fix them together with No.10 x 1" Pozi CSK screws (F201) from alternate sides at no more than 300mm centres.

- If the frames are not installed as a linked pair, at least 6mm clearance will be needed to couple the second frame to the first.

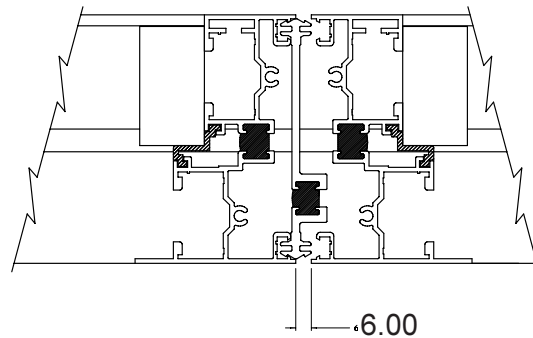

Fig.37
Assembly of Hidden Coupling

8.2 Coupling Sliders to Monaframe (Fig.38)

- Use the slim step-down adaptor A661 to link the vertical slider to Monaframe sections.

- The effective width is 3mm.

- Fix the VSW frame to the coupler through the inner track of the jamb at no more than 600mm centres.

- Fix the Monaframe outer frame through the bead channel, again at a maximum of 600mm pitches.

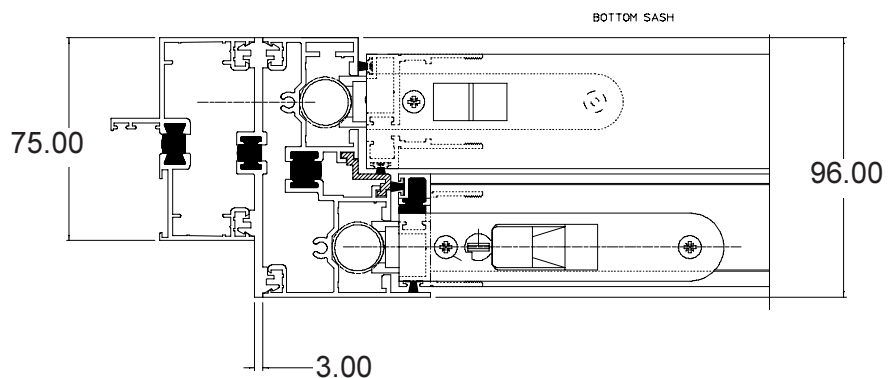

Fig.38
VSW / Monaframe Adaptor

E. USE AND MAINTENANCE

E.1. USE

It is recommended that regular inspection of stays and ironmongery should be carried out during cleaning and in the event of the sash being dropped accidentally onto the stays while unsupported.

The cleaning operation in all cases should be carried out with reasonable care and the weight of the sash supported while gradually lowering it down onto the stays.

1.1 All Models

- Dis-engage the fitch catch(es) and lift or lower the sashes to the required position. Always use two hands to avoid tipping the sash.

1.2 Tilt-in for Cleaning

- Lift the lower sash up, so its bottom rail is above the cill upstand, dis-engage the slide latches from the jambs . Gently lower the sash in and down until the full weight of the sash is supported on the stays. Repeat the above procedure for the top sash.

- The external face of the glass can now be cleaned. Do not lean on the sashes when cleaning.

- Once cleaned, lift the top sash back into the jamb. Always withdraw the slide latches when returning sashes to the vertical. **DO NOT SLAM THEM BACK INTO POSITION.**

E.2. MAINTENANCE

2.1 Frame and Glass

- Use a mild soap solution to wipe down both faces of the sashes and frame.
- This should be carried out annually, or more frequently in areas with high airborne pollutant levels, e.g. chemicals, salt etc.

2.2 Balances

- At the same frequency as the above, check the following points ;
 - Balance fixing screws are tight. Do not over tighten !
 - Balance tube is un-damaged.
 - Connections to pivot shoes are correct and no damage is evident.
 - Balance bottom end is clean. If not, remove dirt and re-lubricate with
 - Torso - Castrol Rustilo DWF.
 - Ultralift & Alumatilt - Multi purpose grease.

E.3. GENERAL

2.1 Frame and Glass

- Check all stops, latches, catches etc. are in place and fixed securely.
- If you have any doubts about the condition of the window report your concern to the appropriate person within your organisation, or the installer.