

Section 3

Residential Door (Direct Fix) System

<u>Title</u>	Page	Current Issue
Contents	3.1	20.02.01
	3.1.1	01.08.00
LIST OF ILLUSTRATIONS	3.2	20.02.01
1. INTRODUCTION	3.3	01.03.00
2. EQUIPMENT	3.4	20.02.01
2.1 Standard Requirements	3.4	
2.2 Recommended Requirements	3.4	
3. PROFILE IDENTIFICATION	3.5.1	20.02.01
	3.5.2	20.02.01
4. ACCESSORIES	3.6	01.03.00
4.1 Door/Side Panels	3.6	
4.2 Monarch Letterplate	3.6.1	01.02.00
	3.6.2	01.08.00
General Arrangement	3.6.3	01.03.00
5. COMPONENT & GLASS FORMULAE	3.7	01.03.00
5.1 Component Measurements	3.7	
5.2 Glass Formulae	3.8	01.08.00
6. DOOR CONSTRUCTION	3.9	01.08.00
6.1 Cutting Techniques	3.9	
6.2 Construction Techniques	3.9	
6.2.1 Woolpile	3.9	
6.2.2 Braces	3.9	
6.2.3 Flipper Seal	3.9	
6.2.4 Foam Infill	3.9	
6.2.5 Cleats & Chevrons	3.9	
6.3 Assembling Details	3.10	01.08.00
6.3.1 Corner Joints	3.10	
6.3.2 Leaf Corner Joints	3.10	
6.3.3 Strike Plates & Face Plates	3.10	
6.3.4 Standard Hinges	3.11	01.08.00
6.3.5 Cathedral Hinges	3.11	
6.3.6 Drainage	3.12	01.08.00
6.3.7 Side Panels	3.12.1	01.08.00
7. INSTALLATION	3.12.2	01.08.00
	3.12.3	01.08.00
7.1 Moniframe Goal Post Door	3.12.4	01.08.00
8. Additional Details	3.12.5	01.08.00
8.1 Rim Latch Option	3.12.5	
	3.12.6	01.08.00
8.2 90° Adjustable Restrictor	3.12.7	01.08.00
	3.12.8	01.08.00

Sapa's policy is one of continual system development and we reserve the right to incorporate design improvements and □ changes. Every effort is made to ensure that all details are correct at time of publication. However, it is the responsibility of the □ customer to check the accuracy of the relevant facts and information before entering into any contract or other commitment. Up □ to date information is freely available from the Sapa Building Systems Webshop.□

All Products and systems which Sapa supply are supplied subject to Sapa's standard Terms and Conditions of Sale current from □ time to time.

(Continued)

9.	Weather Rated Wheelchair Low Threshold	3.13.1	01.08.00
9.1	Introduction	3.13.1	
9.2	Kit Codes	3.13.1	
9.3	Component Identification	3.13.2	01.08.00
	GA - Single Door	3.13.3	01.08.00
	GA - Double Door	3.13.4	01.08.00
9.4	Component Measurements	3.13.5	01.08.00
9.5	Glass Formulae	3.13.6	01.08.00
9.6	Machining Details	3.13.7	01.08.00
9.7	Assembly Details	3.13.8	01.08.00
		3.13.9	01.08.00
		3.13.10	01.08.00
		3.13.11	01.08.00
9.8	Additional Details	3.13.12	01.08.00
10.	Standard Low Threshold	3.13.13	01.08.00
10.1	Introduction	3.13.13	
10.2	Bar Length Codes	3.13.13	
10.3	Component Identification	3.13.13	
10.4	Component Measurements	3.14	01.08.00
10.5	Glass Formulae	3.15	01.08.00
10.6	Machining Details	3.16	01.08.00
10.7	Assembly Details	3.17	01.08.00

List Of Illustrations

Fig. No.	Title	Page No.
3.1	Residential Door - Drill Jigs	3.5.1
3.2a	Residential Door Profile Identification	3.5.1
3.2b	Residential Door Profile Identification	3.5.2
3.3a	Letterplate	3.6.1
3.3b	View on internal elements - Letterplate	3.6.1
3.3c	Letterplate Preparation Detail	3.6.2
3.3d	Letterplate with CKTR6 Detail	3.6.2
3.4a	General Arrangement	3.6.3
3.4b	Jamb Components	3.9
3.4c	Lock Jamb Components	3.10
3.5a	Standard Hinges	3.11
3.5b	Cathedral Hinges	3.11
3.5c	Sectional View thro' hinges	3.11
3.6	Cill bung and End cap fitting	3.12
3.7a	Fixing Side Panels to Door frames	3.12.1
3.7b	Sectional View thro' Side Panels & Door frames	3.12.1
3.8	General Views	3.12.3
3.8.1	Goal Post Door	3.12.4
3.8.2	Rim latch Fitting Scheme	3.12.5
3.8.3	Rim latch Fitting Scheme	3.12.5
3.8.4	Rim latch Fitting Scheme	3.12.5
3.8.5	Rim latch Fitting Scheme	3.12.5
3.8.6a	Rim latch Fitting Scheme	3.12.6
3.8.6b	Rim latch Fitting Scheme	3.12.6
3.8.7a	Restrictor Kit Components	3.12.7
3.8.7b	Restrictor Sectional View	3.12.8
3.8.7c	Restrictor Layout Scheme	3.12.8
3.8.8	General Isometric View of Weather rated Low Threshold	3.13.1
3.8.9	Identification - Low Threshold Profiles	3.13.2
3.8.10	GA of Single Door with Weather Rated Low Threshold	3.13.3
3.8.11	GA of Double Door with Weather Rated Low Threshold	3.13.4
3.8.12	Machining Details	3.13.7
3.8.13	Tray prep Details	3.13.8
3.8.14	Tray to bracket Details	3.13.8
3.8.15	Tray to Jamb Fitting Details	3.13.8
3.8.16	Bracket to Jamb Details	3.13.8
3.8.17	Assembly Details	3.13.9
3.8.18	Base End Cap Details	3.13.9
3.8.19	Sealing Details	3.13.9
3.8.20	Bung Assembly Details	3.13.9
3.8.21	Track to Leaf Assembly Details - Door Leaf	3.13.10
3.8.22	Orientation Sectional Views	3.13.10
3.8.23	Assembly Details - Flush Bolts	3.13.11
3.8.24	Assembly Details - Flush Bolts	3.13.11
3.8.25	Fixing of Flipper seals	3.13.12
3.8.26	General Isometric View of Standard Low Threshold	3.13.13
3.8.27	Identification - Low Threshold Profiles	3.13.13
3.8.28	Machining Details	3.16
3.8.29	Key Dimensional View	3.17

1. INTRODUCTION

The direct fix Monaframe Residential door is supplied in kit form. Each kit contains all the direct fix profiles and internal components which are required to construct a residential door.

The outer frame components are supplied in standard kit sizes and are fully prepared for assembly. If however they require cutting down, use the formulae charts in section 5. Where cut down has taken place, re-preparation of each component is required. Outer frames are mitred with internal elements straight cut.

Operation and Fittings

- Each door is hung with two standard hinges in prepared positions. Please be aware of cut down parameters prior to any machining as hinge position may limit cut down in some cases.

Each door is supplied with a Union Multi-point Hook lock complete with unique strikes and keeps, unless ordered otherwise.

Lever/Lever handles are supplied as standard with a Lever/Pad handle optional.

Please refer to section 4, for optional accessory parts.

Glazing

- The door is glazed using the 'wrap round' method, with pre-selected gasket depending on unit thickness. Rails and stiles are pushed onto the gasket with the rails butt fixed inside each stile.

Weather Performance

- The Monaframe Residential Door system has been independently tested, subject to certain configurations to BS 5368 and has a 'B' classification for air permeability to BS6375 : Part 1.

Refer to Monarch Technical for performance ratings.

Appearance

- All profiles are powder coated to BS6496 : 1991, applied using the stringently quality controlled Sytha Pulvin or Interpon processes. Full gloss white (IP9910G) and semi-gloss dark brown (BS08B29) are available as standard kits, with an alternative (to order) comprehensive range of 389 RAL,BS or metallic colour options .

Limitations

- Refer to Monarch Technical Department for cut down limitations.

2. EQUIPMENT

2.1 Standard Requirements

- (a) Cross cut or pivot saw with minimum traverse for 100mm section.
- (b) Tungsten tipped saw blades (require less sharpening and give a longer working life).
- (c) Hand drill.
- (d) Felt or rubber stripped bench top or trestles to avoid damage during assembly or glazing.
- (e) Felt covered rack system for stocking bar lengths.
- (f) No.2 x Point Pozi screw driver.
- (g) Crimper Kit W570 (See page 1.1 for kit contents) .
- (h) Drill bits - 3.2mm, 4.2mm and 4.8mm.
- (m) Bench Vice.
- (n) Small Bench Router.
- (p) Sash cramp and extension bar to give minimum hold of 2440mm (8'0").

2.2 Recommended Requirements

- (a) Stile Drill Jig and drill - C852 - Thermally Broken Doors.
- (b) Stile Drill Jig and drill - C853 - Non Thermally Broken Doors.
- (c) Simple Pillar drill and bench.
- (d) Allen Key Set - A601.

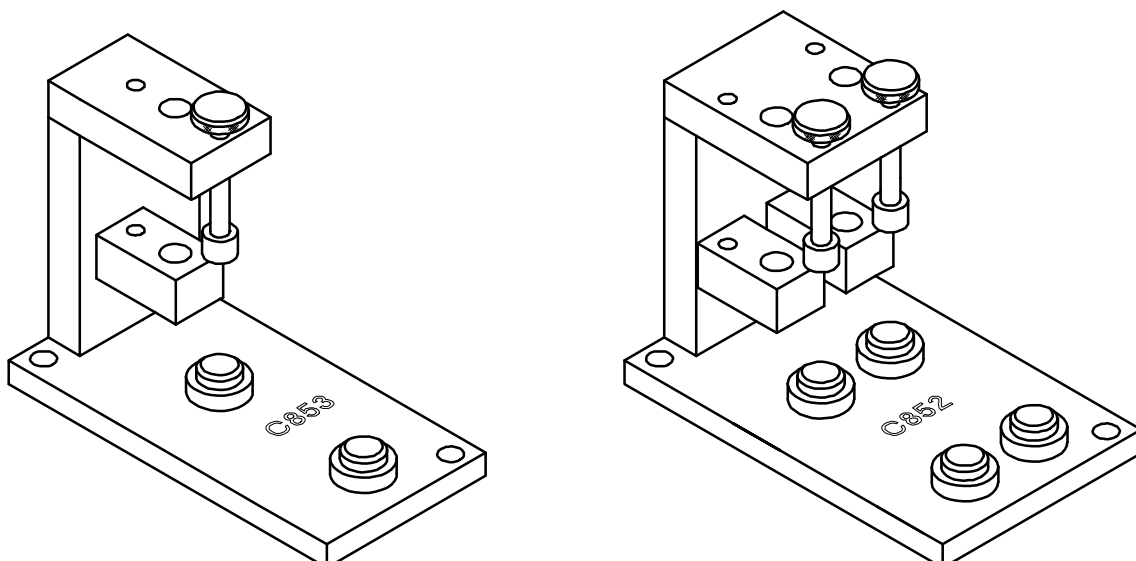
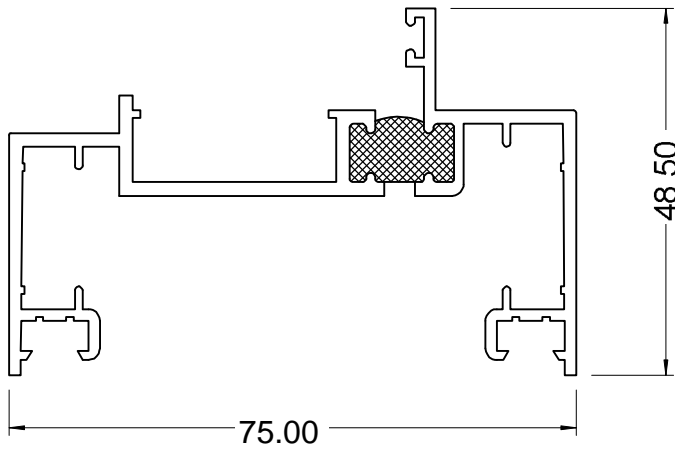
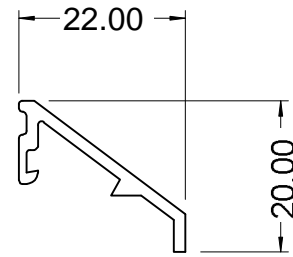

Fig. 3.1
- Door Preparation Drill Jigs

3.0 PROFILE IDENTIFICATION



M973 - Lock/Hinge Jamb & Head



M908 - Weather Bar

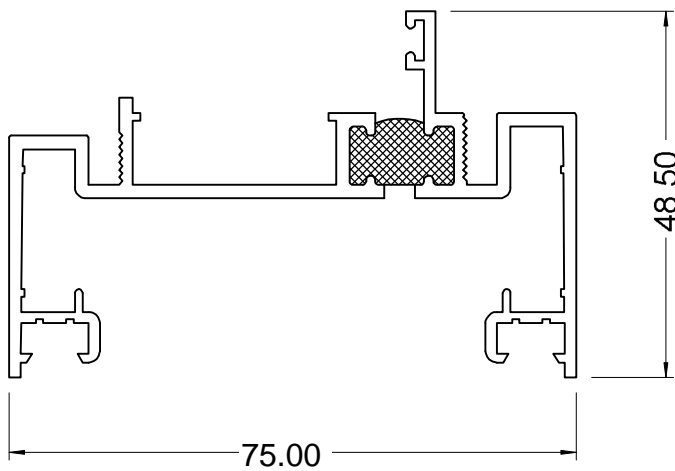

M972 - Cill

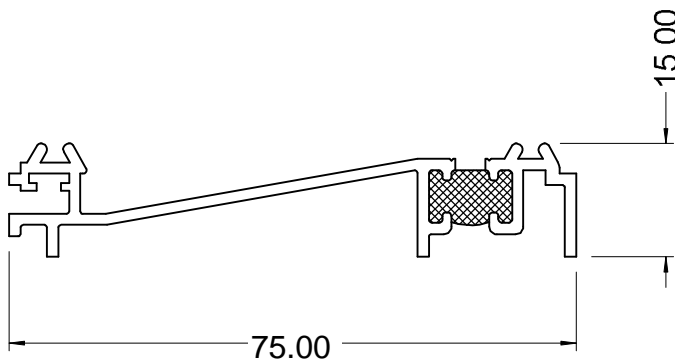

M988 - Drainage Tray (Not in kit)

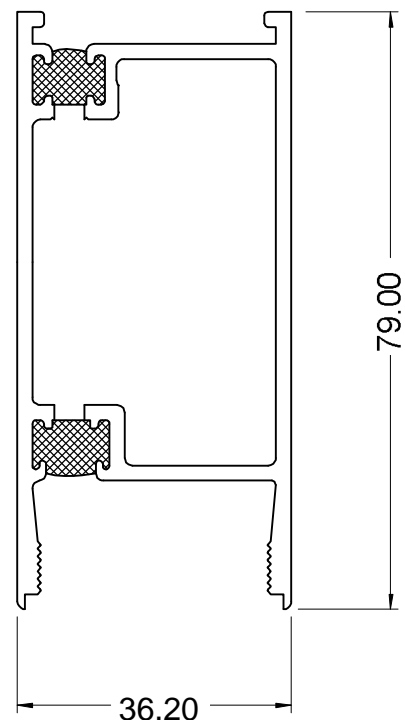

M905 - Lock/Hinge Stile

Fig. 3.2a

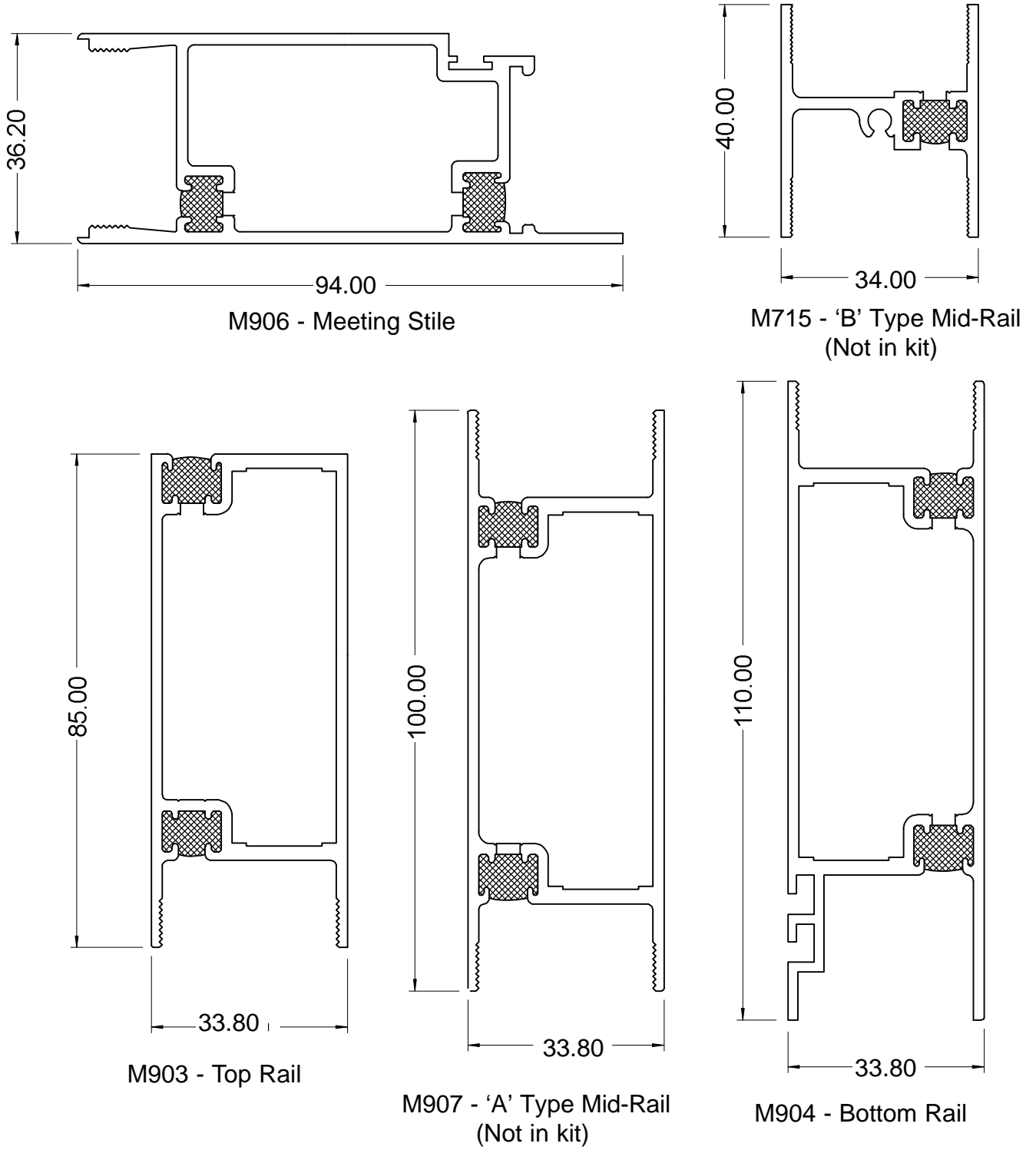

Fig. 3.2b

4.0 ACCESSORIES

All standard kits include a multi-point lock and lever/lever handle. Other options are available on request, refer to Price List for coded options.

Description	Qty	Code	Remarks
Add on cills			
Single Door 135mm (M994)	1	RK-AAHW---C	<i>White-0.959M-With caps</i>
Single Door 135mm (M994)	1	RK-AAHP---C	<i>Brown-0.959M-With caps</i>
Double Door 135mm (M994)	1	RK-ADHW---C	<i>White-1.835M-With caps</i>
Double Door 135mm (M994)	1	RK-ADHP---C	<i>Brown-1.835M-With caps</i>
Drainage Tray (75mm Wide)	1	A9885000W	<i>White-5.0M</i>
Drainage Tray (75mm Wide)	1	A9885000BP	<i>Brown-5.0M</i>
Shootbolt Pack (Head & Cill)	1	A1580	
BS3621 Legge Deadlock	1	C3367	
Escutcheon Pack	50	A3396W/E/G	<i>For use with C3367</i>
Security Cylinder with Anti-drill Inserts	1	A1532S/G/E/C	
Standard Lock Cylinder	1	A1288E/S/G/C	
Euro Half Cylinder with Thumbturn	1	C1290C	
Euro Full Cylinder with Thumbturn	1	C1291C	
Lever/Pull Adaptor Clips	10	A1553	<i>To convert Pad to Fixed</i>
Stile End Cap Pack	50	A1646W/E	
4mm Black Glass Gasket	25M	C1274	
6mm Black Glass Gasket	25M	C1218	
20mm Black Glass Gasket	25M	C1224	
22mm Black Glass Gasket	25M	C1225	
24mm Black Glass Gasket	25M	C1203	
25mm Black Glass Gasket	25M	C1253	
26mm Black Glass Gasket	25M	C1254	
24mm White Glass Gasket	25M	C1203W	
26mm White Glass Gasket	25M	C1254W	
Toe & Heeling Pack	1	A1033	<i>Selection -Wedges/Packers</i>
Flipper Seal	50M	A3004	
Spanners	5	A3235	<i>To suit door Panels</i>
Lever/Lever Handle Set	1	A1570W/E/S/G	<i>(Union M'Point)</i>
Lever/Pad (Front Door) Handle Set	1	A1571W/E/S/G	<i>(With split spindle)</i>
Lever/Lever Dummy Handle Set	1	C3256W/S/G	
Split Spindle	10	A1486	
Rim Latch	1	A1437W/E/S/G	
Allen Key Set	1	A601	
Flush Bolt Pack	1	A937	

- Also available are both prep'd and non-prep'd mid rails to suit letterplate.

4.1 Monarch Door/Side Panels

Monarch door panels (745mm x 1908mm) can be supplied glazed or unglazed, with or without letterplate preps. Also available are Base panels (745mm x 940mm) and side panels (745mm x 2082mm or 745mm x 1041mm).

Refer to Price List for types of style and coding implications when ordering.

4.2 Monarch Letterplate (A1645 W/E/S/G)

This letterplate set is made up of extruded aluminium and has both internal and externally sprung flaps. The external flap gives a generous 147° of angular movement and should help alleviate problems where letterplates are fitted to bottom rails.

Internal nylon brushes reduce drafts and the complete letterplate assembly has a telescopic sleeve action which will cover a range thickness of 16-34mm.

This letterplate **A1645 W/E/S/G** will replace the existing letterplates **A1429 W/E/S/G** and **A1430 W/E/S/G**.

This product is fully compliant to BS2911, and will be available as standard in 4 different finishes; painted White(W) and Black(E), Silver(S) and Polished Gold(G).

Fig. 3.3a
- Front of Letterplate (Closed)



147° Flap Movement

Fig. 3.3b
- Front of Letterplate (Open)

Internal Nylon Brushes

- Fixings;

Letterplates are fixed from the inside of the building with self tapping screws.

There are 3 different lengths of screw provided with each letterplate assembly with each set covering a specific range in rail thickness.

2 off No.8 x 1" Pozi C'sk Hd	-	to suit Recessed rail
2 off No.8 x 1¼" Pozi C'sk Hd	-	to suit Infill Panel
2 off No.8 x 1½" Pozi C'sk Hd	-	to suit Mid-rail

- Kits;

Pre-prepared rail kits will be available as per existing rail kits.

Residential door kits - If a complete letterplate assembly is required, order a prep'd midrail and letterplate separately. An 'A' type mid-rail with a letterplate prep, has the letters 'X' and 'L' added to the normal code.

I.e. RKA-ASW would become RKA-ASXWL. ('A' Type)

It can be easily retro-fitted to existing doors with the minimal amount of work and is supplied with fixing screws. Drill new fixing holes 9.0mm dia holes at 275mm centres and remove shaded area as shown.

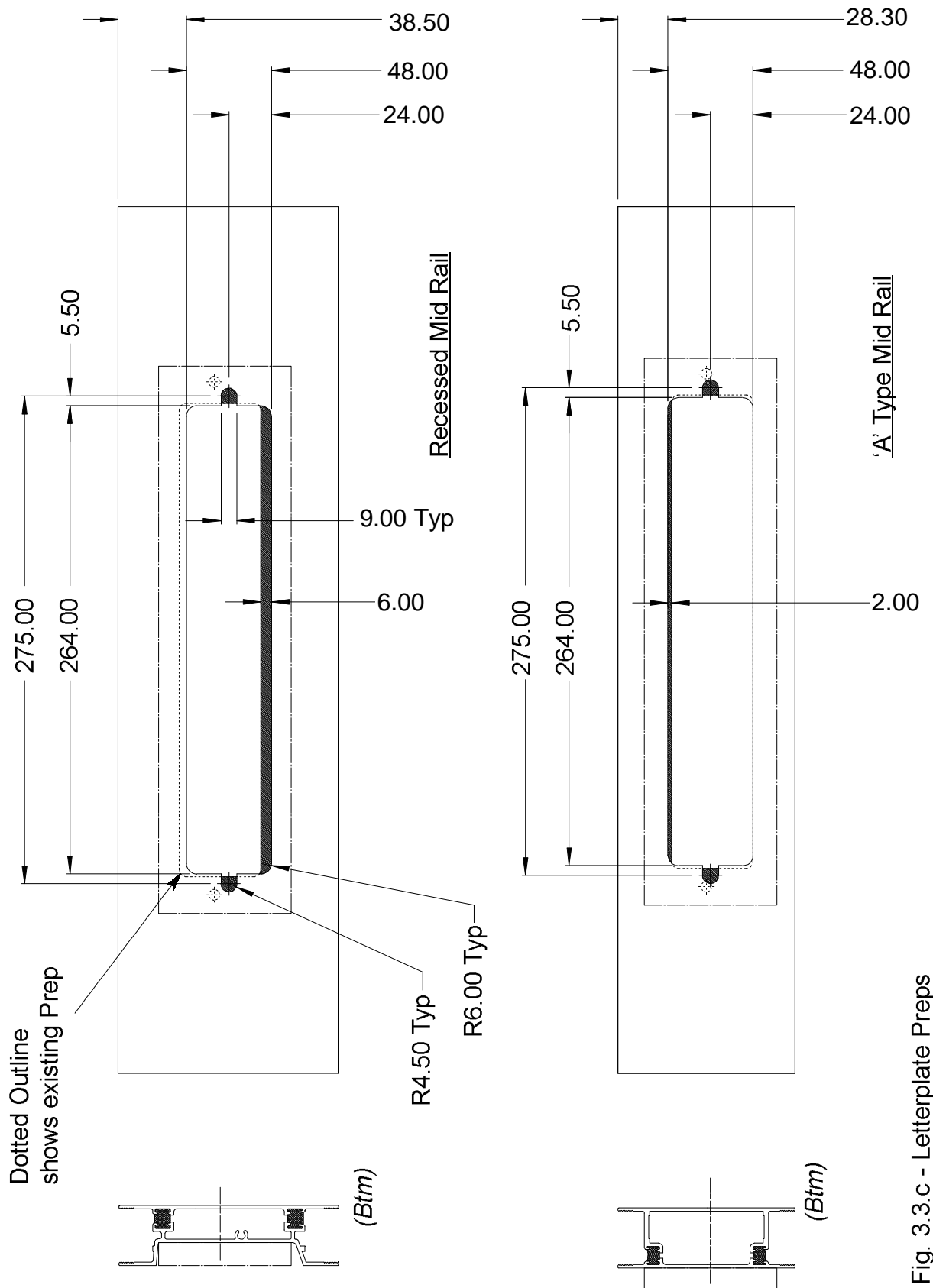
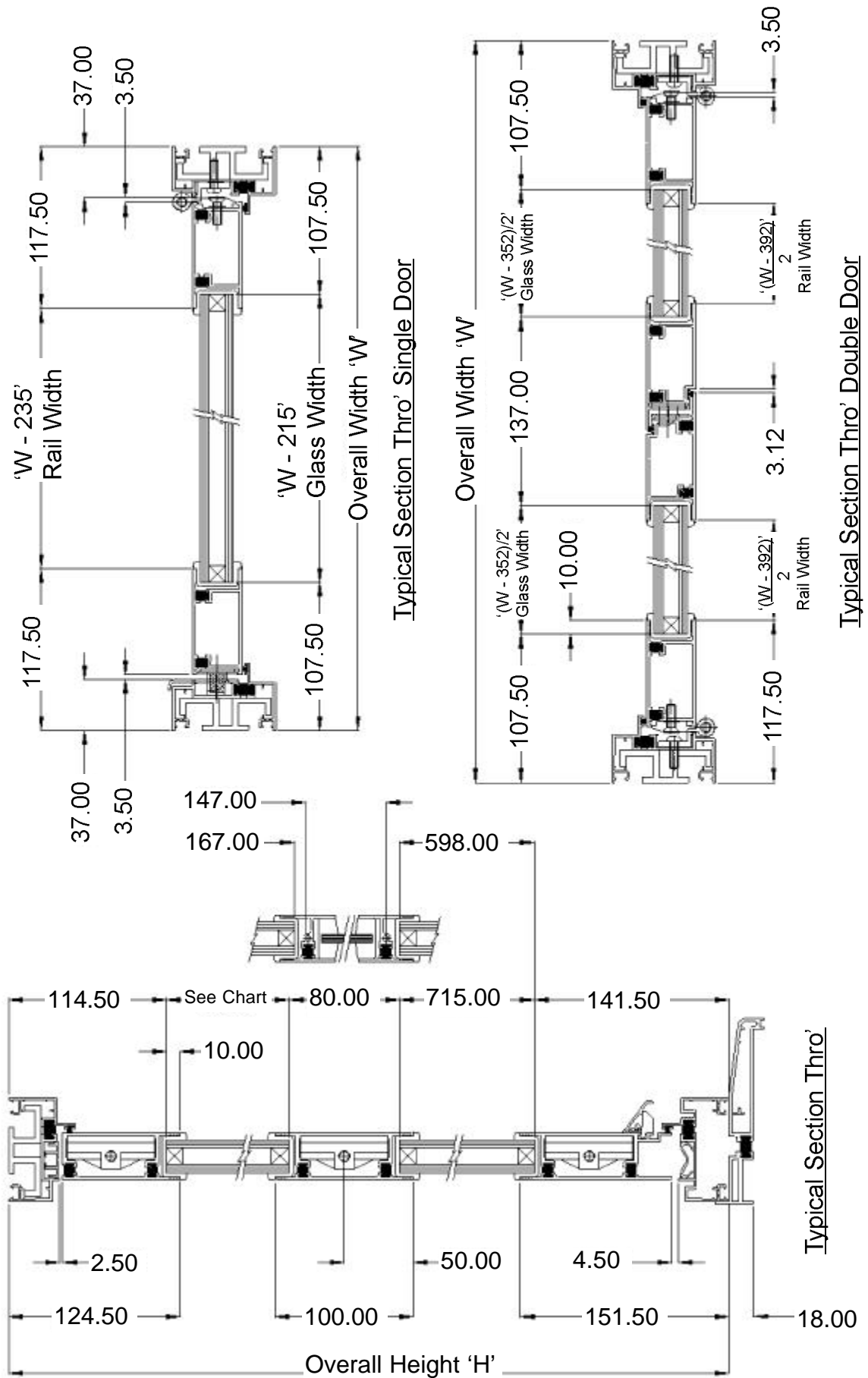

Fig. 3.3.c - Letterplate Preps

Note - Refer to window section for details of fitting a letterplate to a CKTR6 transom.

Fig. 3.4a - General Arrangement



5.0 COMPONENT & GLASS FORMULAE

5.1 Component Measurements

- The formulae for component measurements described in this paragraph exclude the add-on cill and are for Monaframe type doors only with the latest modified hinges - (C1529 'A4' - Ref Technical Bulletin TB1075D '2').
 - Where components are mitred or angle cut, dimensions are taken over the longer edge of the angle. All dimensions are in (mm).

- 'W' is the overall width of the outer frame and 'H' is the overall height of outer frame.
- The minimum double door width cut down is 1090mm wide.
- An add-on cill will add 18mm to the height where used.
- A drainage tray will add 11mm to the height where used.

Component	Standard Monaframe	
	Single	Double
Head	W	W
Cill	W	W
Add On Cill or Drainage Tray	W	W
Jambs	H	H
Stiles	H - 81	H - 81
Rails (*See notes)	W - 235	$\frac{W - 392}{2}$
Weather Bar (In)	W - 100	W -(Rail+262) W -(Rail+232)
Weather Bar (Out)	W - 80	W -(Rail+250) W -(Rail+220)

(*) - Where double doors are cut down below 1450mm in width, it will be necessary to remove an extra 1mm from each rail width. This is to overcome the reduced arc of the door leaf.

i.e. **Rail length = (W-394)/2**

- For Cathedral Hinged doors, rail length for single doors is **(W-237)**. For double doors **(W-394)/2**.

Standard **Single door** Kit Sizes are **885w x 2087h**, **961w x 2087h** and **961w x 2163h**.

Standard **Double door** Kit Sizes are **1685w x 2087h** and **1837w x 2163h**.

5.2 Glass Formulae

No Midrail				
	Width		Height	
	Single	Double	Single	Double
Std Monaframe	W - 215	$\frac{(W - 352)}{2}$	H - 256	H - 256

With Midrail (Std Height)				
	Width		Height	
	Single	Double	Single	Double
Top - Std Monaframe (With A Type)			H - 1051	H - 1051
Bottom (With A Type)	W - 215	$\frac{(W - 352)}{2}$	715	715
Top - Std Monaframe (With B Type)			H - 1021	H - 1021
Bottom (With B Type)			598	598

With Midrail (Non Std Height)				
	Type A		Type B	
	Top	Bottom	Top	Bottom
Std Monaframe	T - 154.5	B - 181.5	T - 198	B - 225

Std Height 'Dim B' = 896.50 for A Type Mid rail
 = 823.00 to centre of B Type Mid rails.

Important Note ;

Where double doors are below 1450mm in width, it will be necessary to remove an extra 1mm from the glass width.

i.e. **Glass Width = $(W-354)/2$**

- For Cathedral Hinged doors, glass width for single doors is **$(W-217)$** .
 For double doors **$(W-354)/2$** .

- All dimensions are in millimetres.

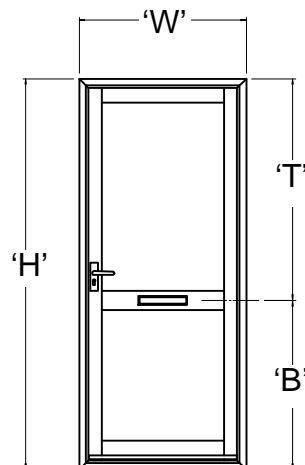

6. DOOR CONSTRUCTION

6.1 Cutting Techniques

Calculate the size of outer frame required, allowing for 18mm if an add-on cill is to be used. Allow for any clearance or deviation in host aperture at this stage.

Cut down the kit, mitre cutting the outer head, cill and jamb components to 45° in accordance with the formulae in section 5. Ensure handing is correct prior to any cut down of jambs. The cill should be cut so drainage slots are at equal distances from each end.

Cut down the leaf components from the top with straight cuts. The add-on cill is straight cut to the door aperture width. If the cill is to be flush with outer frame edge, remove an extra 4mm to allow for the end caps.

Important Note ; We strongly recommend that during the cutting down of lock or hinge stiles from standard kits, after each cut the stile is angled down to clear out swarf; although hook units are encased, the swarf must be removed out of the end away from the mechanisms. Failure to carry out this procedure may cause potential problems later with locks becoming permanently damaged or unit failure with hooks jamming in the locked position.

6.2 Construction Techniques

6.2.1 Woolpile

Prior to crimping the outer frame, insert woolpile (C704G - Grey / C704E - Black) into the head and cill with woolpile (C158A - Grey / C639A - Black) into the jambs.

6.2.2 Braces

Fit a sufficient number of braces (C3135) into the outer frame at suitable fixing and adequate packing points. Only hinge jamb braces will be pre-fitted. Fixings should be at no more than 600mm centres and a maximum 150mm from the corners.

6.2.3 Flipper Seal

Flipper seal (A3004 - 50M) can be fitted into the Monaframe clip pocket either before or after crimping. No flipper seal is required along bottom edge of frame where add-on cills are required.

6.2.4 Foam Infill

Foam infill (A3131) should be supplied fitted within outer frame profiles, it can be removed then replaced by push fit into the outer frame around top and sides only. It is to prevent air circulation. Foam will need to be cut short of braces and fixings.

6.2.5 Cleats and Chevrons

Slide the required cleats (C3122 / C3123) into their corresponding pockets within the outer frame, applying sealant liberally over cleats and mitred faces.

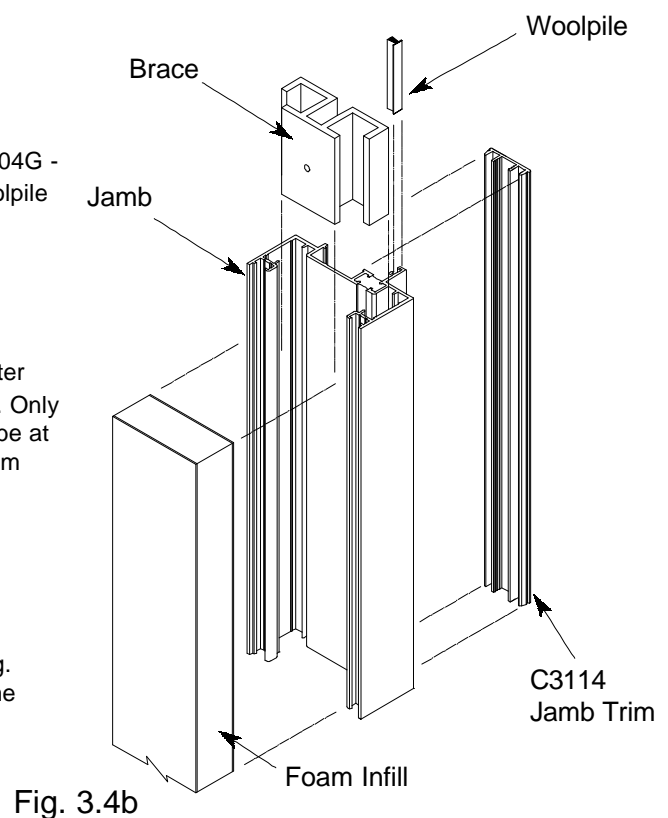

6.3 Assembling Details

6.3.1 Corner Joints

Check, where required, that woolpile and braces are fitted prior to crimping.

If not already applied, apply sealant to both mitred faces and assemble loosely onto the crimper assembly. Remove flipper seals locally about the corners to clear the operation of the crimper heads.

Secure the joint onto the crimper assembly (refer to section 1) and crimp the joint. After crimping, clean off any surplus sealant. Replace the seals.

For crimping the outer frame use anvil insert W571 with a pair of W574 punches.

6.3.2 Leaf Corner Joints

Rails are butt fixed into the recesses of the stiles and secured with M8 x 50mm Socket Cap screws (F91). Tension blocks (C900) are fitted inside the rail ends by unscrewing grub screws out to engage into the rail. Each corner is then assembled with a nylon corner block (C1490), spreader plate (C914) and M8 spring washer (F12). Refer to the Workshop Procedures (C930) for more detailed information.

Important Note ;

When using white wrap round gasket for glazing, due to potential problems with staining from colour transfer, do not use the black self adhesive support pads on rails or stiles when toeing and heeling the door leaf. The hard plastic wedges siliconed in place may be used instead.

6.3.3 Strike Plates and Face Plates

All strike / keeps are supplied with the door kits and face plates fitted to the lock stiles.

Single Doors - Fix the Strike plate to the jamb thro' spacers with No.8 x 1" Pozi Hd Csk ST screws. All kit jambs will have prepared Ø3.50 pilot holes for approximate positioning. Repeat procedure for both end keep plates.

Double Doors - Strike plates, keeps and face plates are all factory fitted to their corresponding stiles within the kit.

- Multi-point Single Door Strike/Keep Pack - C1573
- Mortice Single Door Strike Pack - C1576
- Multi-point Double Door Strike/Keep Pack - C1575

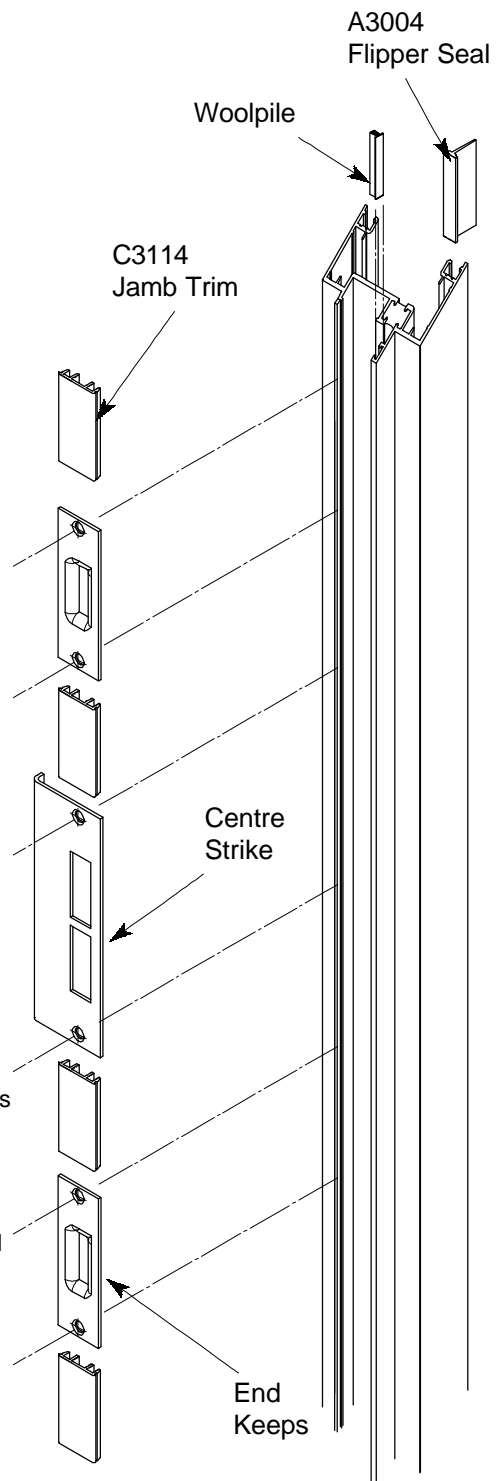

Fig.3.4c

6.3.4 Standard Hinges

All kits are supplied with two hinges as standard. Additional hinges can be obtained by ordering **C1529 W/E/BP**. It is recommended that where a third hinge is required, it should be positioned 200mm down from top hinge between centres. A small area of jamb outer frame upstand will require knibbing out and rivnuts fitted to both jamb and stile. Refer to 3.5c.

Each hinge is fitted to the stile with M6 x 20 C'sk Head Socket screws - 3 off per hinge, and the complete door leaf is fitted to the jamb with M6 x 20 Button Head Socket screws - 3 off.

Slots in the hinge will give adjustment both horizontally and vertically. Plastic packers are also supplied within the kits for additional adjustment of leaf position. Refer to Installation Guide (C2103) for more detailed fitting instructions.

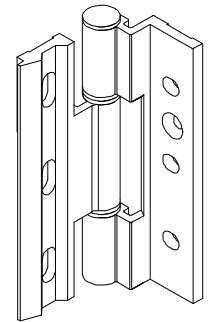

Fig. 3.5a

6.3.5 Cathedral Hinges

Cathedral (or Parliament) hinges are also available both in standard kits and separately as **C3246 W/E/BP**.

They are designed to give an offset pivot point to allow the door leaf to clear a dwarf wall cill with a maximum projection of 55mm from the frame face. The hinge allows the door leaf to open a full 180° but is only suitable for Monaframe doors.

The hinge pin is of hardened steel for added security.

Reduce all rails by 2mm. Fit cathedral hinges into jamb so that the flange passes into the machined slot in the jamb and tighten the M6 x 20 Button Head Socket screws - 3 off. Repeat for both hinges. Offer the door onto the hinges so that the hinge flange passes into the machined slot on the stile and tighten the M6 x 20 C'sk Head Socket screws - 3 off per hinge.

Close the doors to check the door operation is smooth with no clashing. If they clash place a black plastic packer between the meeting and locking stile at the point they clash and close the doors.

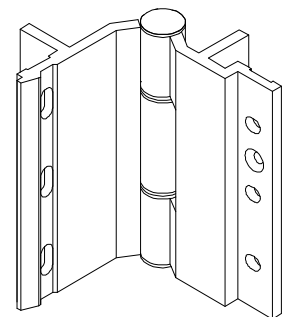
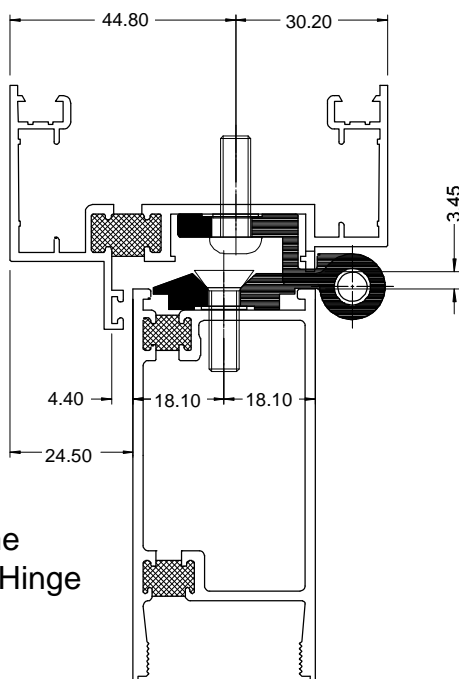

Fig. 3.5b

Drill through the prepared holes in the outer face of the jamb and stiles into the hinge flanges, using Ø3.8 drill bit - countersink holes in outer face to suit fixing screws No.8 x 1/2" Pozi Hd Csk ST screws (F167). Fit the screw cover caps (C3247W/E) with a dab of silicone sealant.

Open doors and remove packer. If the door leaves still clash, loosen the hinge to jamb fixings and slide half a grey packer (1.5mm) down the inside half of the hinge on the jamb. Re-tighten screws and check door operation.



Monaframe Standard Hinge (C1529)

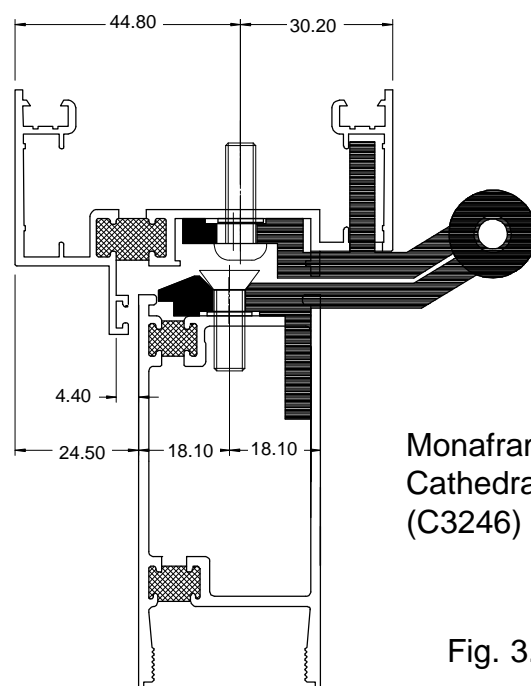

Monaframe Cathedral Hinge (C3246)

Fig. 3.5c

6.3.6 Drainage

All Monafame door kits are supplied with drainage slots incorporated into the cill as standard.

An add-on cill may be fitted either in the workshop or on site. Load bearing cills are available in 135mm, 155mm or 190mm in wide. Refer to cill profiles. Prepared 135mm cills with drainage slots incorporated are available to order - see Accessory codes in section 4.

Take a profiled plug and apply a liberal amount of silicone sealant to the plug location area on the cill, making sure the thermal break channel in the add-on cill is fully sealed.

Fit a black profiled plug (C3129) 75mm from each end of the outer frame cill, see figure 3.6. This is essential to prevent water draining down through the door into the cill, from tracking along and penetrating into brick work/masonry.

To fit the add-on cill, place the completed outer frame down on to the add-on cill in the position required. Drill Ø3.50 pilot holes down through the cill into the add-on cill. Open up the holes in the door cill to Ø4.50 clearance holes and countersink if necessary, to suit No.8 x 1 3/4" C'sk Pozi Hd screws (W312S). Fixings should be at 300mm intervals or other suitable positions.

If alternative fixing screws are used, care must be taken not to drill full depth breaking through both add-on cill walls or problems with water penetrating brickwork will occur.

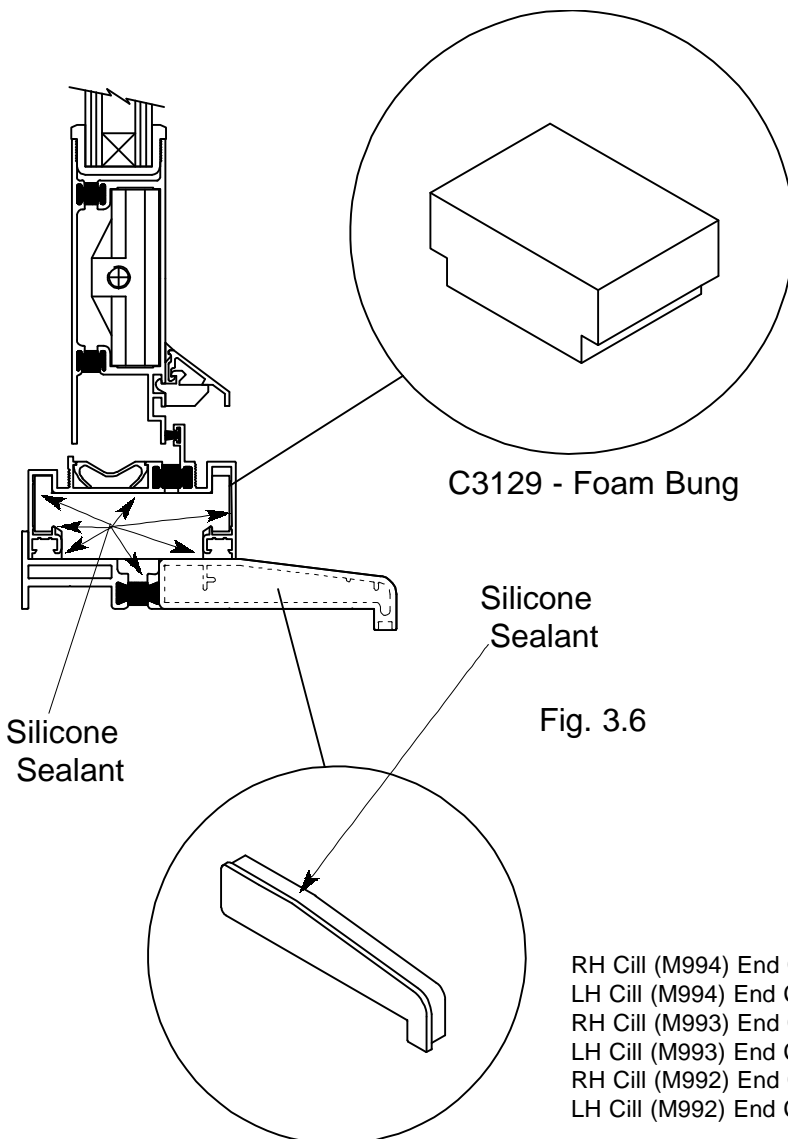

RH Cill (M994) End Cap 135mm	A3185W/BP/E (20 off)
LH Cill (M994) End Cap 135mm	A3184W/BP/E (20 off)
RH Cill (M993) End Cap 155mm	A3187W/BP/E (20 off)
LH Cill (M993) End Cap 155mm	A3186W/BP/E (20 off)
RH Cill (M992) End Cap 190mm	A3189W/BP/E (20 off)
LH Cill (M992) End Cap 190mm	A3188W/BP/E (20 off)

6.3.7 Side Panels

Side panels are constructed with Monafame (75mm) sections, CKDFF casement outer frame is shown. When an 'A' type mid-rail requires simulating within a side panel, CKTR6 (100mm) is used to line through.

Casement profiles can be bought in bar length, refer to relevant manual pages or Price List.

The side panel is attached to the door frame by using one of two hidden couplers, CKA11 being for any load bearing situations or A983. Both are square cut, and should run the full height with a deduction of 25mm top and bottom to clear the crimper corners.

CKA11 will require Ø10.5 clearance holes where hinge rivnuts foul the coupler - Ref Fig 3.7a. Once the frames are clipped together, secure assembly with No.10 x 1 1/2" Pozi Pan Hd ST screws (W331) at 300mm pitches thro the thermal break area.

With A983, clip the frames together taking into account the orientation of the coupler and secure assembly with No.10 x 1 1/2" Pozi Pan Hd ST screws (W331) at 300mm pitches thro the thermal break area.

A bead of clear or colour matched silicone sealant down the outside face of the outer clip before assembly is a recommendation for additional protection. Wipe off excess sealant.

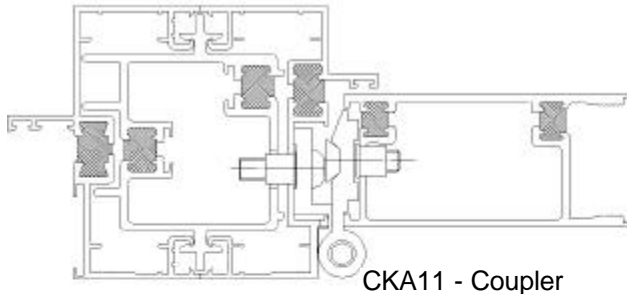

CKA11 - Coupler

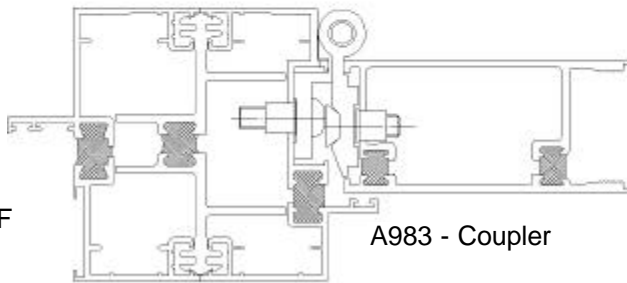

A983 - Coupler

CKDFF

Fig. 3.7a

Where the sightline of a resi-door bottom rail requires lining through, an adaptor CDA15 in combination with CKTR6 is glazed into the side panel as per fig 3.7b

The adaptor is cut to the same length as the transom and is located in the bead grooves of the outer frame and transom, both joints should be sealed with clear or colour matched silicone sealant.

Mid rail height is shown as the standard height for an A type mid rail. Alter if necessary to suit if the midrail is a non standard height.

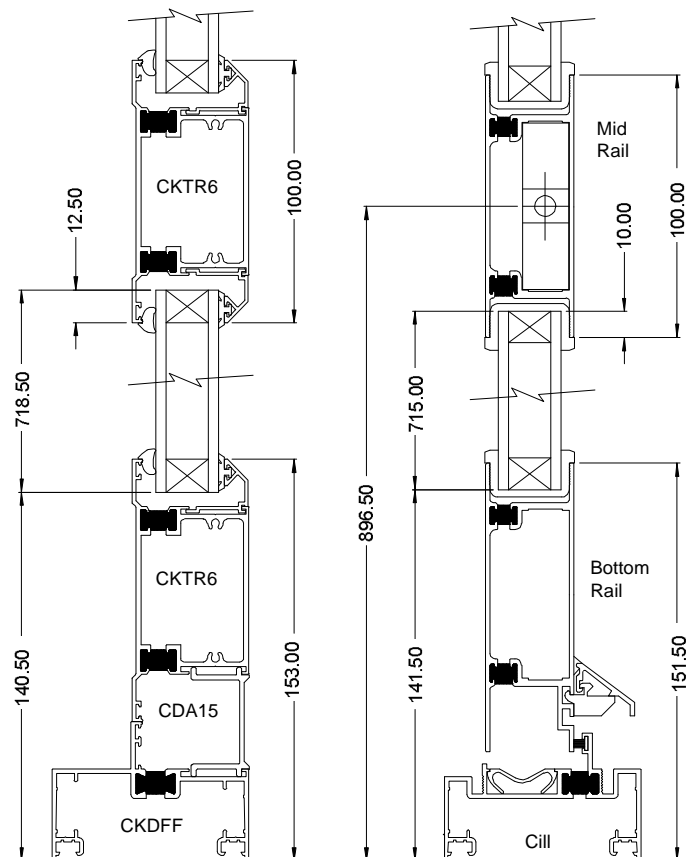

Fig. 3.7b

7.0 INSTALLATION

1. Check that the masonry opening is the correct size for the frame and add-on cill where used.
2. Check the masonry for soundness and decide on the number and positions of fixings.
3. Adjust the braces to align with the fixing points and fit the foam between braces.
4. Install flipper seal (C3004) in outer leg of frame only where frame meets brickwork. Fit the foam cill end plugs (C3129) and silicone seal around plugs as per section 6.25.
Fit cill end caps in position bedded on silicone sealant
5. Fit the frame into the prepared aperture.
6. Drill the clearance holes to suit No.8 x 1 1/2" Pozi Pan Hd screws for all screw fixings in the jambs and head as required. Do not drill through cill thermal break.
7. Drill and plug the fixing holes into the masonry.
8. Engage the fixing screws into the rawl plugs and fix the frame loosely into the aperture.
9. Check the frame diagonals, also width and height at several points.
10. Pack the frame at the fixing points to square up the frame and to ensure that the frame components are not bowing.
11. Tighten the fixing screws and re-check the measurements. Adjust any packing as required.
12. Cut the plastic trims to length. The jamb trim(C3114/C3118) is to be cut from the top, cill trim(C3125) from both ends and the head trim from either end. When fitting, do not hit the plastic trims directly, use a piece of wood.
13. Depending on the handing of door, i.e. open in or out, fit one of the supplied rubber seals (C3116/7) into the groove in the cill closest to the outside of the door. This will leave the inner groove free to collect any condensation from the inside of the door leaf.
14. Hang the door leaf using the countersunk machine screws as supplied.
15. Adjust the leaf position to align with the outer frame. The design gap around the leaf is 2/3mm top, 4/5mm bottom and 3/4mm on either side. The hinges can be adjusted up and down by tightening the socket countersunk and cap screws accordingly. Adjustment of leak in and out is achieved using plastic packers behind the hinge leaves.
16. Fit the strike plates, keeps and shootbolts.
17. Fit handles, weather bars and any trims not already fitted.
18. Check the operation and fit of door.
19. Secure the hinges with final fix suitable screws, i.e. No.10 x 5/8" .
20. Silicone seal around the perimeter of the frame against the brickwork. The flipper seal will give a barrier to help support the silicone sealant, it may be necessary to adjust the flipper seal.
21. Clean paint finish with nothing stronger than white spirit.
Stubborn marks may be removed with T-Cut or similar mild abrasive.
White touch up paint is available.

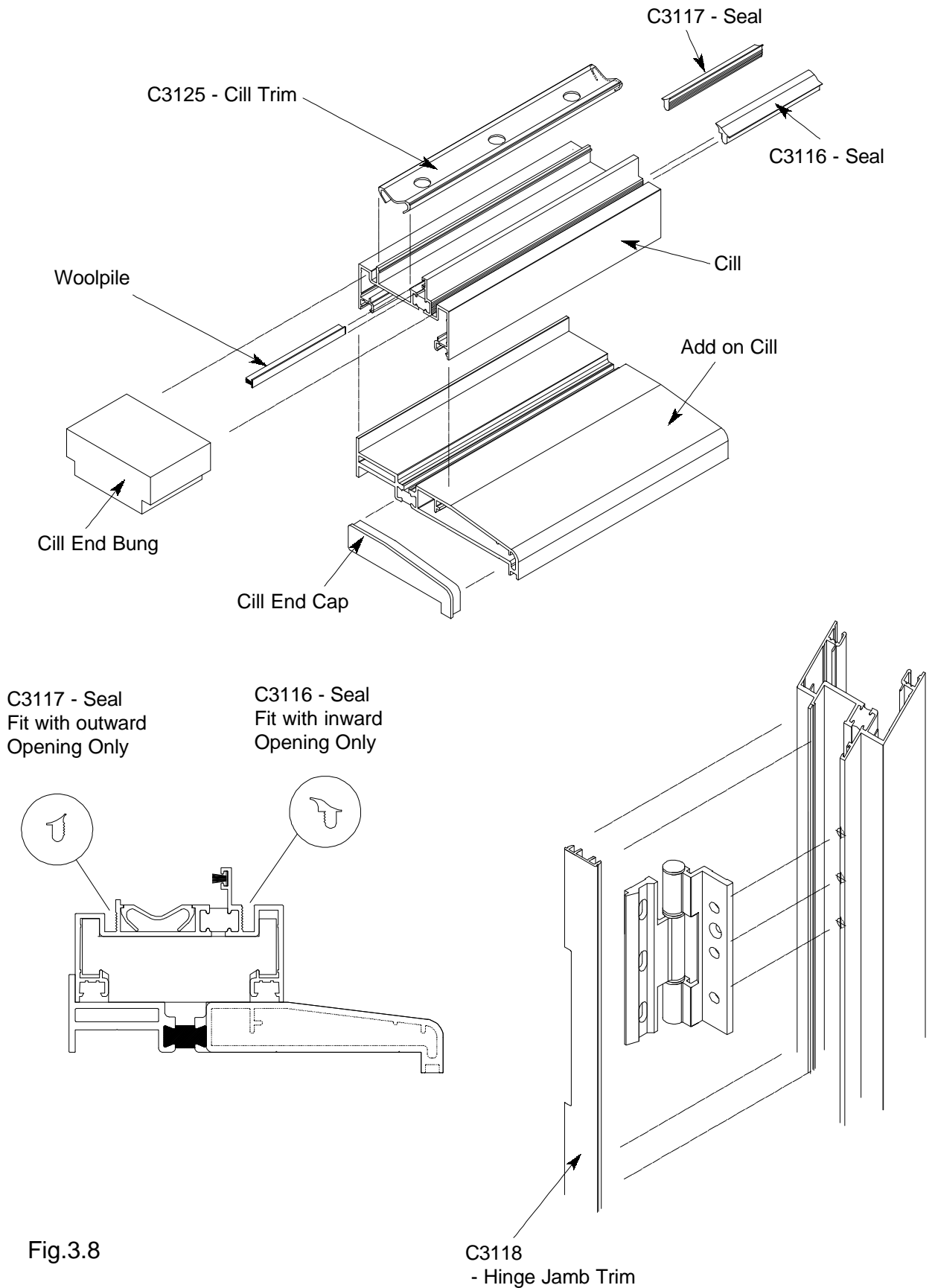

Fig.3.8

7.1 Moniframe Goal Post Door

The following procedure is used for where a standard Moniframe door kit is to be cut down into a 'goal post door.' The door will have no cill and its leaf will have 5mm of clearance on its underside.

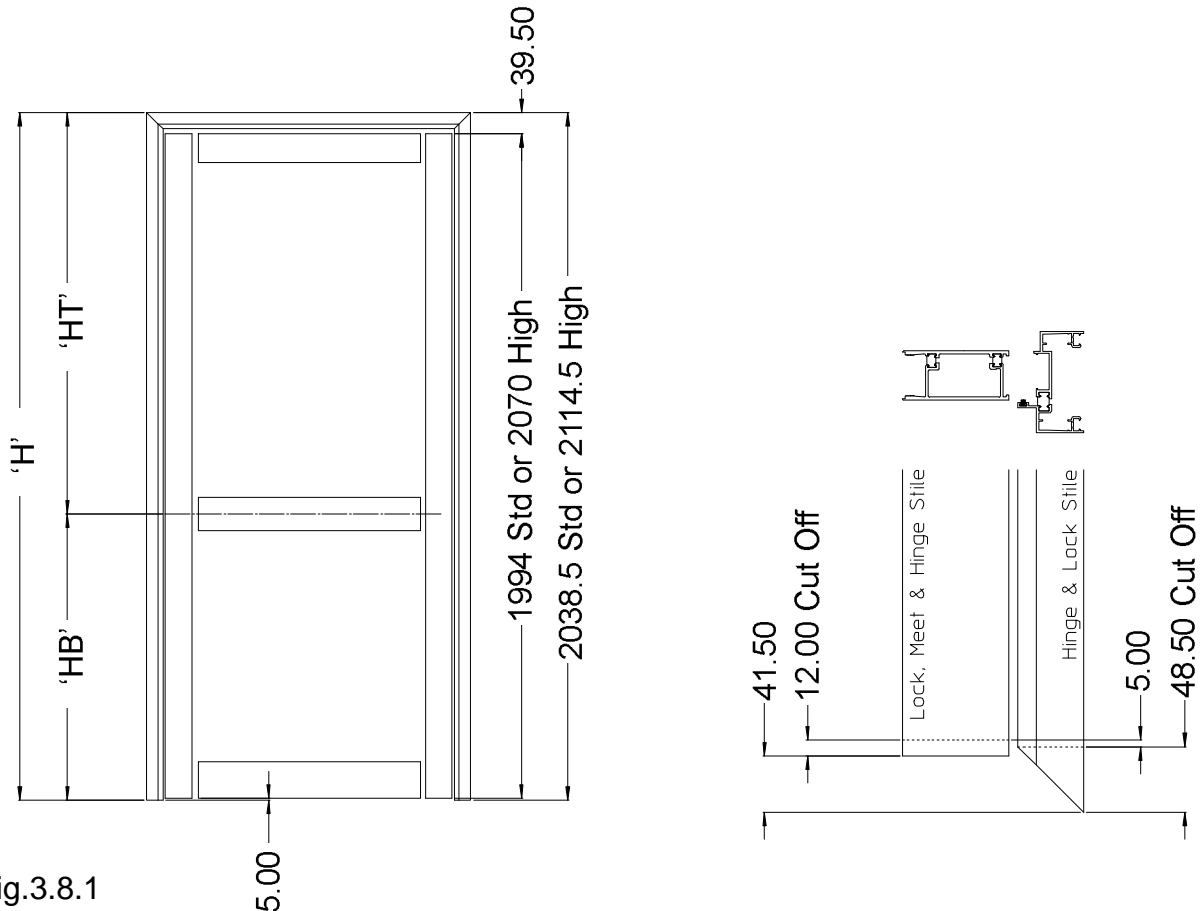

Fig.3.8.1

1. Lay out all components and establish the handing required.
2. From the bottom of the kit as handed square cut the jambs :-
 - a. Reduce jamb length to 2038.50mm for a standard kit.
 - b. Reduce jamb length to 2114.50mm for a high kit.
3. From the bottom of the stiles :-
 - a. Reduce stile length to 1994mm for a standard kit and re-prepare bottom fixing hole.
 - b. Reduce stile length to 2070mm for a high kit and re-prepare bottom fixing hole.
4. For a further reduction in height :-
 - a. Mitre cut jamb from the top to the new length required.
 - b. The stile length, cutting from the top only, will be the same reduction as the jamb.

5. Glass formulae :-

Note, All dimensions are taken from the outer end of the jambs to the centre line of mid-rail or centre line of infill panel if a 'B' type rail used.

	'A' Type Mid-rail	'B' Type Mid-rail
Full Height Pane	H - 219	H - 219
Top Pane	HT - 154.50	HT - 198.00
Bottom Pane	HB - 144.50	HB - 188.00

Important Note - Handle and mid-rail heights will now be 49mm lower than standard height.

8. Additional Details

8.1 Rim latch Option (Inward Opening Only)

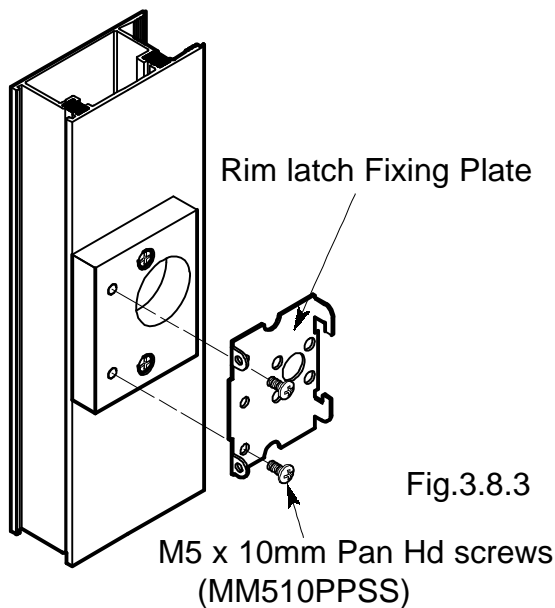
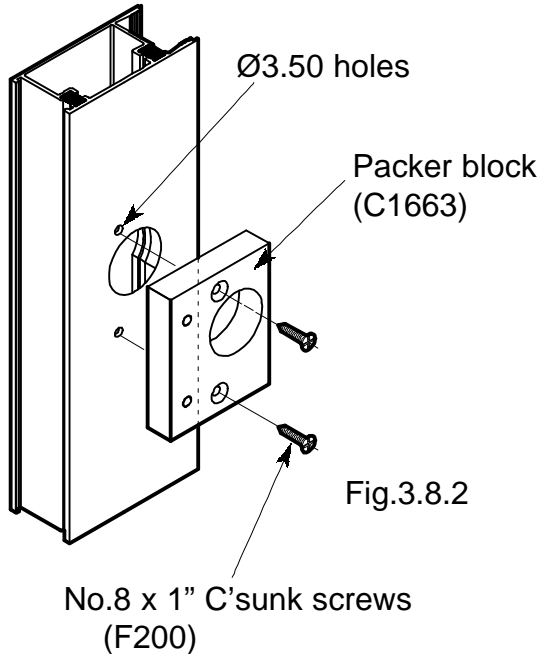

- Fix the cylinder, and Finger pull where required, through the stile using the grooved connecting screws. These too will require cutting to length and de-burring.

Note, when finally tightening these screws, position and hold the cylinder in its correct orientation. Take care not to over tighten the connecting screws or difficulty may be experienced in assembling the latch.

Fitting instructions for a Union Rim latch to a Monarch Direct fix Residential door

- This option is only suitable for pre-prepared inward opening door kits and uses Union Rim latch (A1437) with Packer block kit (A1665).

- Install the door to the normal recommended procedure making sure the door leaf is hung centrally and has a good closing action.

- Offer the packer block up to the prepared lock stile, aligning both cylinder holes, making sure the front edge of the packer block is flush to the stile edge.

- Spot through countersunk holes in the packer, and drill 2 holes Ø3.50 thro' the inner stile wall. Fix the packer to the stile using the No.8 x 1" countersunk screws. See figure 3.8.2.

- Locate the rim latch fixing plate onto the packer block and secure with M5 x 10mm Pan Headed machine screws. See figure 3.8.3.

- Cut the cylinder connecting bar to its required length and offer the cylinder up into the stile. The bar must be long enough to protrude through the stile and into the main rim latch body. See Figure 3.8.4.

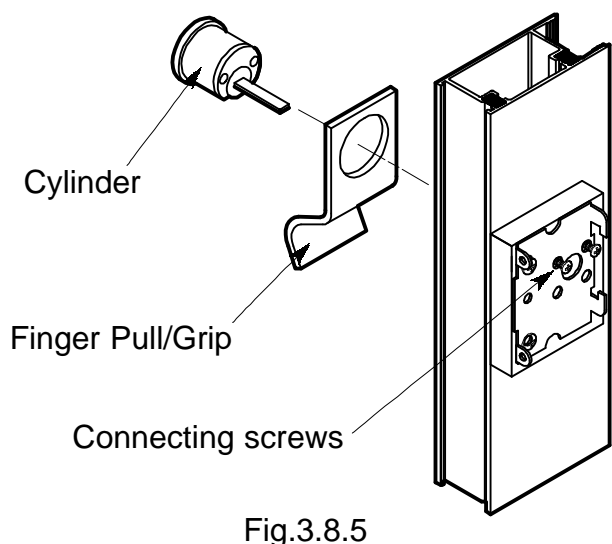
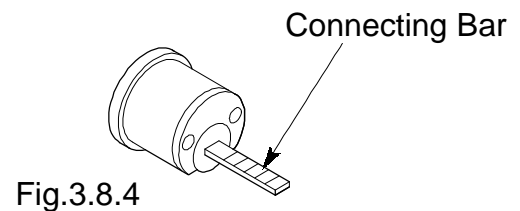

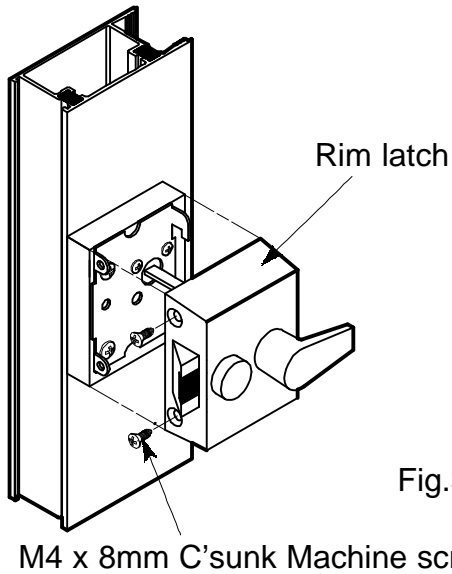

Fig.3.8.6a

- Fix the rim latch to its mating fixing plate by using the 2 off, M4 x 8mm countersunk machine screws (Supplied with Rim latch). See figure 3.8.6.
- Check the latch and key operation.

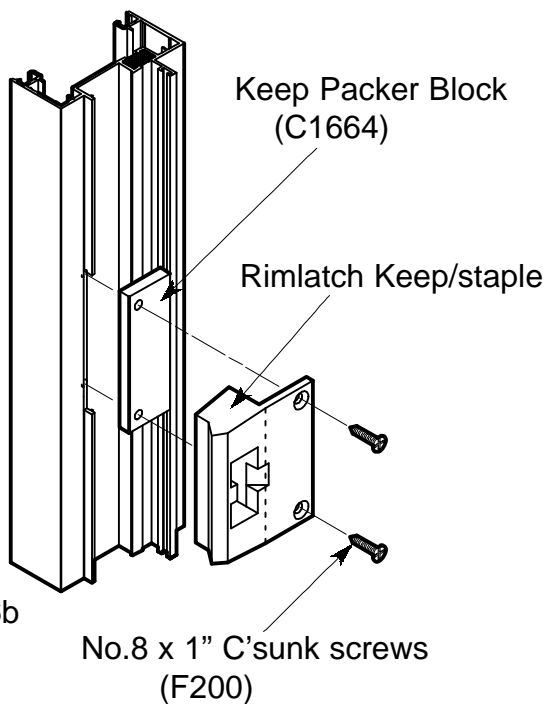
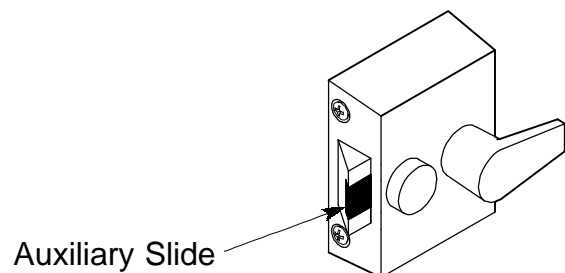

Fig.3.8.6b

- Offer the Keep packer block up and into the outer jamb, aligning up the fixing holes. Fix through keep / staple using No.8 x 1" countersunk screws. See figure 3.8.7.
- Check the door operation, making sure latch engages into keep. The gap between latch and staple must not exceed 5mm when the door is closed or the anti-thrust mechanism will not function correctly.

- Note ;
The auxiliary slide **MUST NOT** enter staple.



8.2 90° Adjustable Restrictor (A1685)

Subject to availability, an Adjustable Restrictor can be used where a door is to be prevented from opening past a desired angle. This restrictor can be used to limit the door leaf between 70° and 110° from the closed position, and has a built in Nylon friction block and strong buffer spring.

It is suitable for Monaframe Residential doors only and requires minimal preparation to the outer frame. The top rail must be swapped for a mid rail to allow the restrictor to sit inside the rail, thus affecting glass cut downs and rail to stile fixing hole. Refer to Monarch Technical for full details.

The top rail fixing position will vary according to the desired restricted angle. Fig.3.8.7c shows approximate position for achieving 90° restriction.

Restrictor Kit A1685 comprises of :-

- Item 1. - 1 Off - Head Restrictor Stay (C1682)
- Item 2. - 2 Off - Top Rail Support Block (C1683)
- Item 3. - 2 Off - Head Support Block (C1684)
- Item 4. - 4 Off - Head Fixing screw (ST834CPSS)
- Item 5. - 2 Off - Top Rail Fixing screw (ST8114CPSS)
- Item 6. - 1 Off - Fitting Leaflet

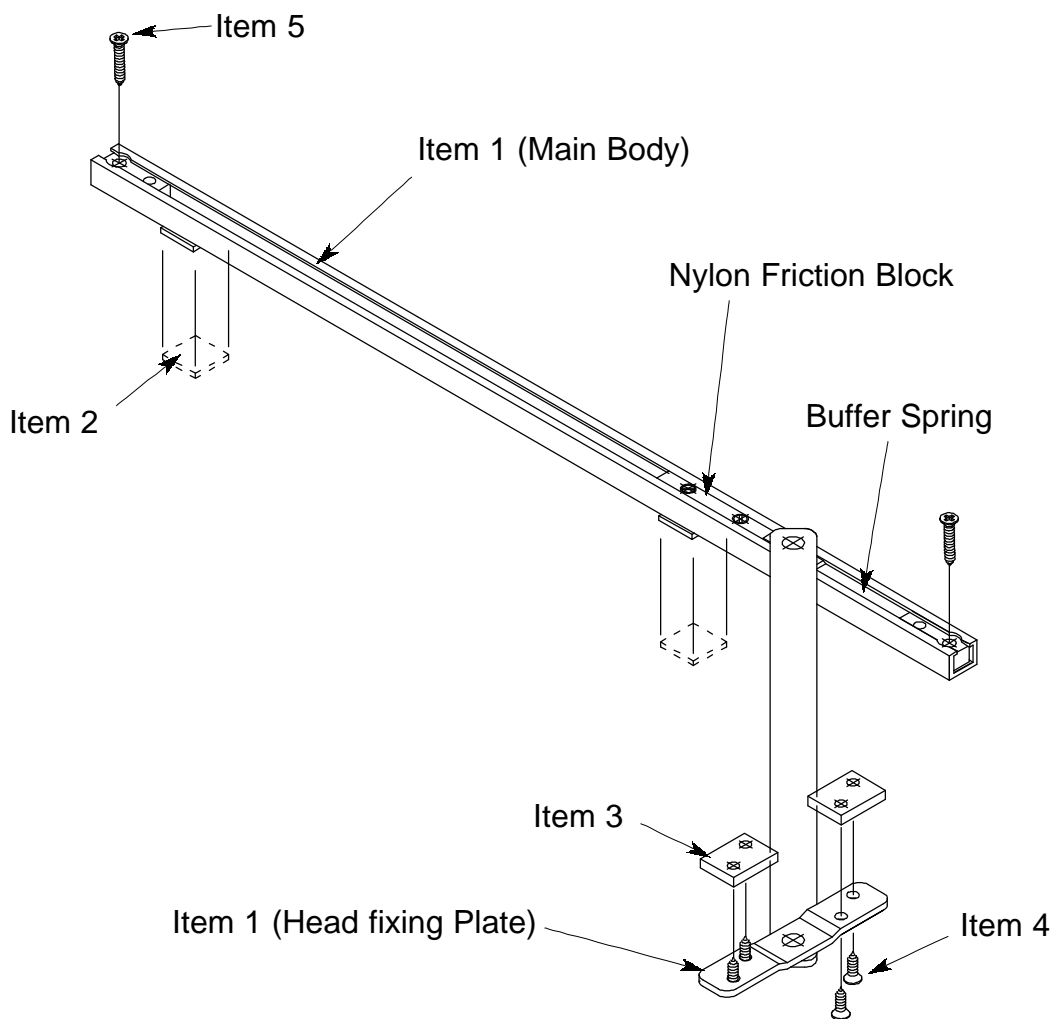

Fig.3.8.7a
Restrictor Kit Components

Fitting Instructions :-

- Fix the head restrictor plate (Item 1) up through the support blocks (Item 3) into the pre-drilled pilot holes within the outer frame head, using No.8 x 3/4" Pozi C'sunk Hd S/T screws. (ST834CPSS)

- Open the restrictor up, as per figure 3.8.7a, and position the main restrictor body into the top channel of the top rail.

- Taking the damping spring into account, position the main body onto the rail support blocks (Item 2) to achieve the required restricted angle, fix down with No.8 x 1 1/4" Pozi C'sunk Hd S/T screws. (ST8114CPSS)

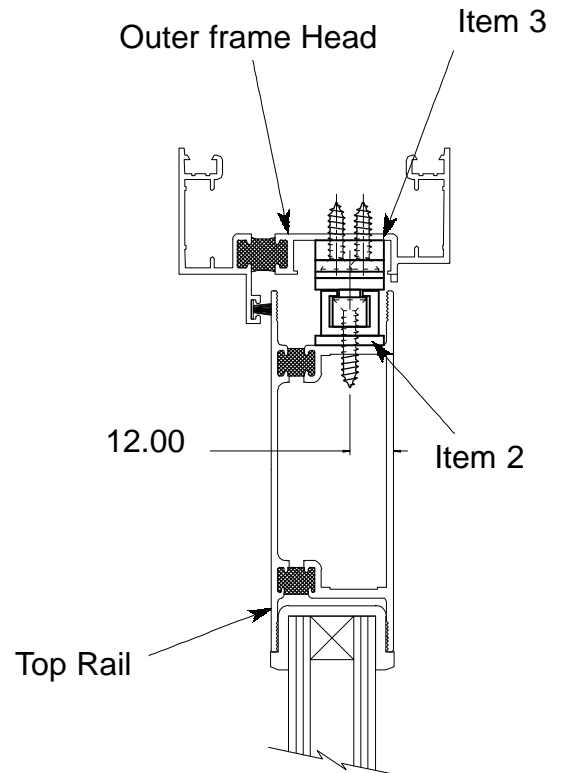

Fig.3.8.7b

- Positions shown in Fig.3.8.7c are an example of the approximate position for 90° restriction. Holes in top rail are to be drilled Ø3.50 to suit required angle.

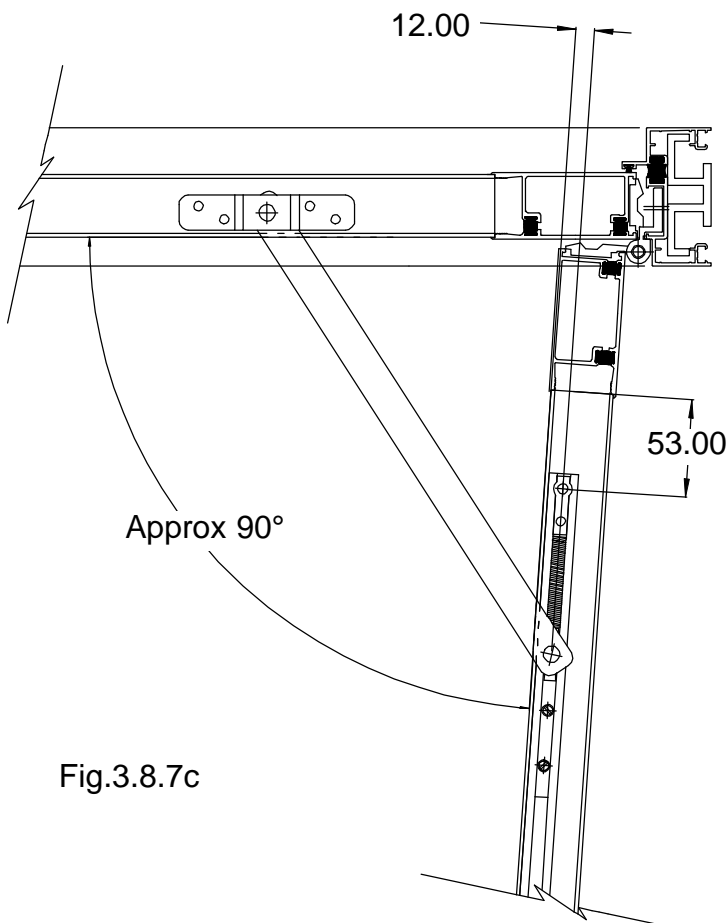

Fig.3.8.7c

Note :
Please note, where this restrictor is used, a cut out preparation 350mm by 2mm is required, at a position 200mm from the hinged corner. This preparation is to enable the swinging arm to rotate through.

9.0 Weather Rated Wheelchair Low Threshold

9.1 Introduction

This Low Threshold Cill has been designed for use with Monarch Monaframe Residential doors and can achieve a weather rating of 50 Pa Air/Water. It provides an easy access option for wheelchair use and replaces the need to use the normal standard cill with upstand.

The threshold is supplied in kit form with stiles prepared to accept the seal carrier running under the stiles and along the bottom rail cavity. The threshold and corresponding components are prepared at one end only, with the fabricator preparing the opposite end once the final width is known.

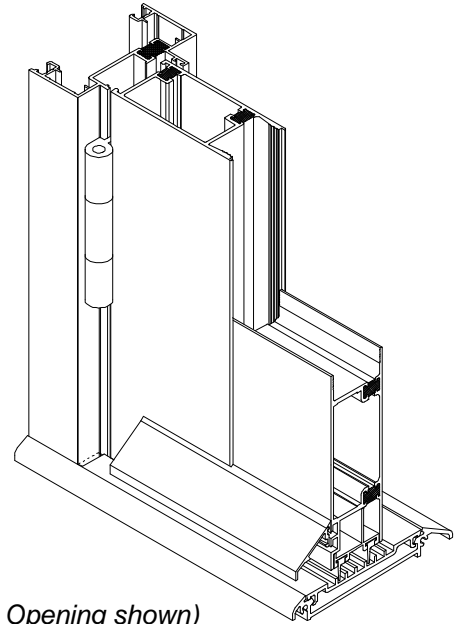

Fig.3.8.8
(Outward Opening shown)

9.2 Kit Codes

Codes for weather rated low threshold kits are configured by ;

RK-A-					<i>Resi - Thermal - Monaframe - Low Threshold</i>
	S				<i>Standard Kit - 885w x 2087h or 1685w x 2087h</i>
	H				<i>High Kit - 961w x 2163h or 1837w x 2163h</i>
	F				<i>Special Kit - 961w x 2087h</i>
		W			<i>White Poly Powder Coat</i>
		P			<i>Brown Poly Powder Coat</i>
		S			<i>Silver Anodized</i>
			A		<i>Multi-point Locking</i>
			B		<i>Mortice Locking</i>
				S	<i>Silver Lever / Lever Handle</i>
				W	<i>White Lever / Lever Handle</i>
				E	<i>Ebony Lever / Lever Handle</i>
				G	<i>Gold Lever / Lever Handle</i>
				5	<i>White Lever / Pad Handle</i>
				6	<i>Silver Lever / Pad Handle</i>
				7	<i>Ebony Lever / Pad Handle</i>
				8	<i>Gold Lever / Pad Handle</i>
				-	<i>No Handle</i>
				L1TS	<i>LHH Open In - Low Threshold Single Door</i>
				L2TS	<i>LHH Open Out - Low Threshold Single Door</i>
				R1TS	<i>RHH Open In - Low Threshold Single Door</i>
				R2TS	<i>RHH Open Out - Low Threshold Single Door</i>
				L1TD	<i>LHH Open In first - Low Threshold D'Door</i>
				L2TD	<i>LHH Open Out first - Low Threshold D'Door</i>
				R1TD	<i>RHH Open In first - Low Threshold D'Door</i>
				R2TD	<i>RHH Open Out first - Low Threshold D'Door</i>
				BS	<i>With BS Lock</i>
				H	<i>With Cathedral Hinges</i>

9.3 Component Identification

- The Threshold is made up of 4 main components.

- | | | | |
|----|------------------------------|----|------------------------------|
| 1. | Threshold Base (M995 - Mill) | 2. | Threshold Tray (M996 - Mill) |
| 3. | Flipper Track (M997 - Mill) | 4. | Flipper (105/184) |

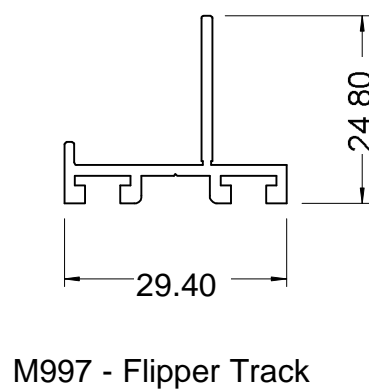
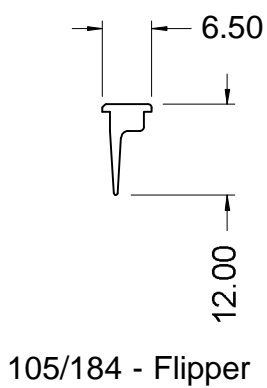
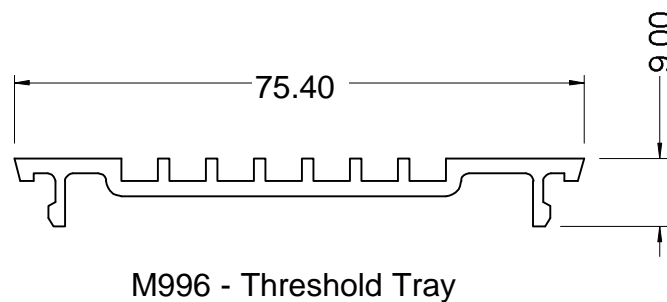
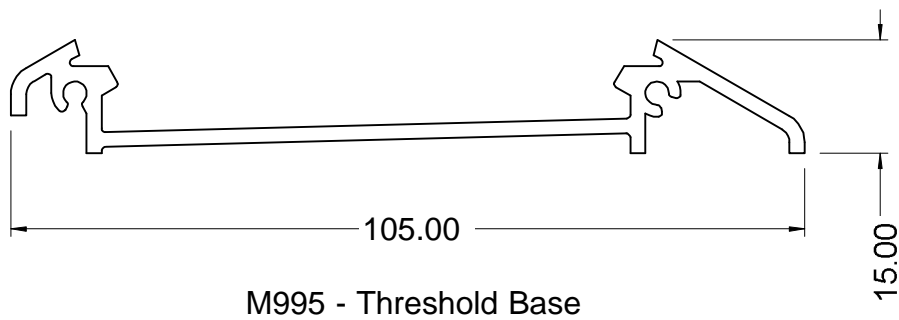

Fig.3.8.9

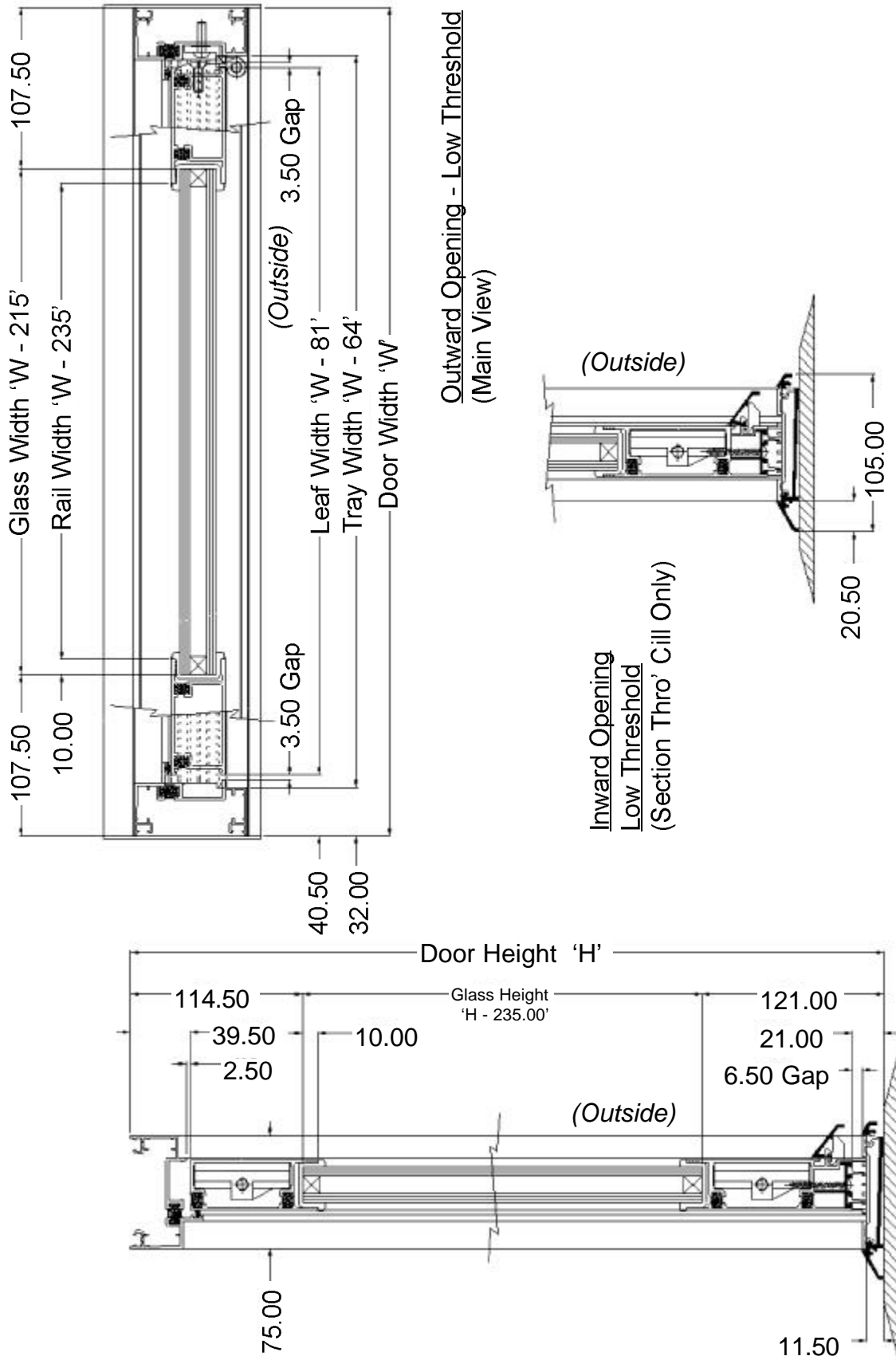
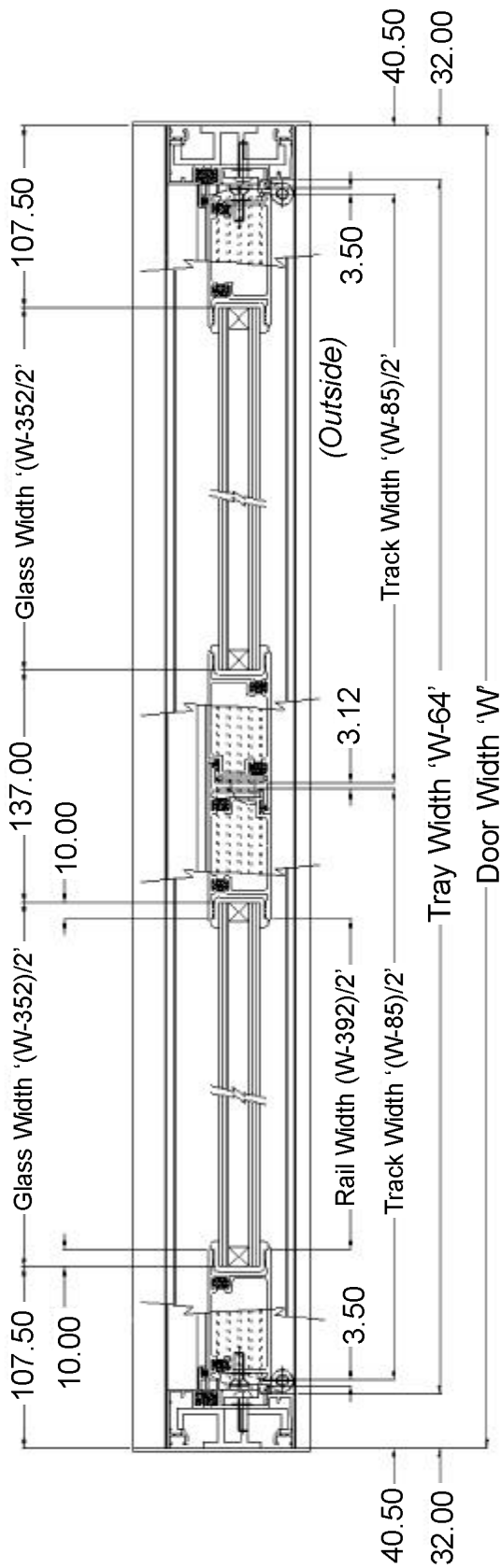
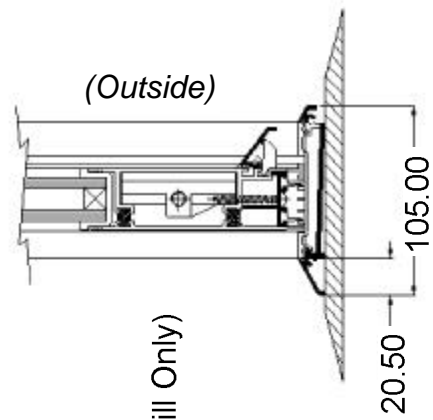

Fig. 3.8.10
GA for Single Door - Low Threshold



Outward Opening - Low Threshold
(Main View)



Inward Opening Low Threshold
(Section Thro' Cill Only)

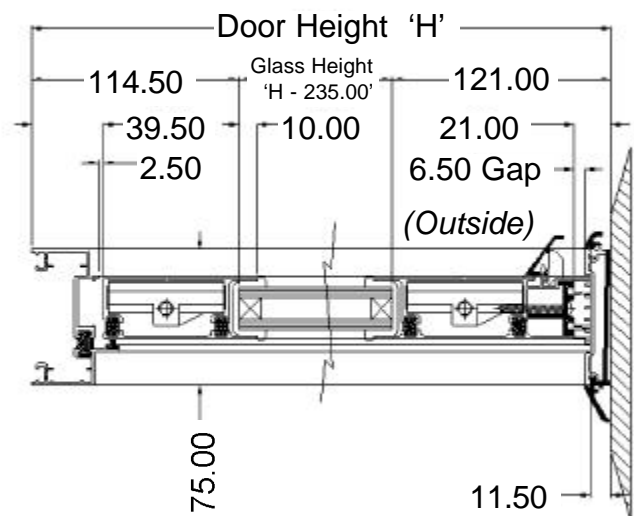

Fig. 3.8.11
GA for Double Door - Low Threshold

9.4 Component Measurements (Weather rated Low Threshold)

- Where components are mitred or angle cut, dimensions are taken over the longer edge of the angle. All dimensions are in (mm). These formulae are only valid for the Weather rated Low Threshold with the latest modified hinges - (C1529 'A4' - Ref Technical Bulletin TB1075D '2').

- The handing of the door will define the prep details for the threshold components and must be cut down and prepared as per the machining details.

- 'W' is the overall width of the outer frame and 'H' is the overall height of outer frame.
- Allowance for any clearance to brickwork must be considered when cutting kit components to final size.
- The minimum double door width cut down is 1090mm wide.
- The Threshold Base is straight cut, no end preps are required - drainage is pre-machined.
- The Threshold Tray and Flipper Track both require cutting back and notching at one end.
- End caps are 2mm thick.

Component	Low Threshold	
	Single	Double
Head	W	W
Jambs	H - 11.5	H - 11.5
Stiles	H - 60.5	H - 60.5
Rails (*See notes)	W - 235	$\frac{W - 392}{2}$
Flipper Track	W - 81	$\frac{W - 85}{2}$
Threshold Tray	W - 64	W - 64
Threshold Base	W	W
Weather Bar	Cut to Size	Cut to Size

(*) - Where double doors are cut down below 1450mm in width, it will be necessary to remove an extra 1mm from each rail width. This is to overcome the reduced arc of the door leaf.

i.e. **Rail length = (W-394)/2**

- For Cathedral Hinged doors, rail length for single doors is **(W-237)**. For double doors **(W-394)/2**.

Standard **Single door** Kit Sizes are **885w x 2087h**, **961w x 2087h** and **961w x 2163h**.

Standard **Double door** Kit Sizes are **1685w x 2087h** and **1837w x 2163h**.

9.5 Glass Formulae - to suit 'Weather rated' Low Threshold

No Midrail				
	Width		Height	
	Single	Double	Single	Double
Single Glass Unit	W - 215	$\frac{(W - 352)}{2}$	H - 235	H - 235

With 'A' Type Midrail (Std Height)				
	Width		Height	
	Single	Double	Single	Double
Top - Low Threshold	W - 215	$\frac{(W - 352)}{2}$	H - 1031	H - 1031
Typ Bottom Unit	W - 215	$\frac{(W - 352)}{2}$	715	715

Non-Standard 'A' Type Midrail Heights				
	Width		Height	
	Single	Double	Single	Double
Top - Low Threshold	W - 215	$\frac{(W - 352)}{2}$	T - 155	T - 155
Typ Bottom Unit	W - 215	$\frac{(W - 352)}{2}$	B - 161	B - 161

Std Height 'Dim B' = 876.00 for A Type Mid rail

Important Note ;

Where double doors are below 1450mm in width, it will be necessary to remove an extra 1mm from the glass width.

i.e. **Glass Width = $(W-354)/2$**

- For Cathedral Hinged doors, glass width for single doors is **$(W-217)$** .
For double doors **$(W-354)/2$** .

- All dimensions are in millimetres.

- Dimension 'B' and 'T' are to centre line of mid-rail.

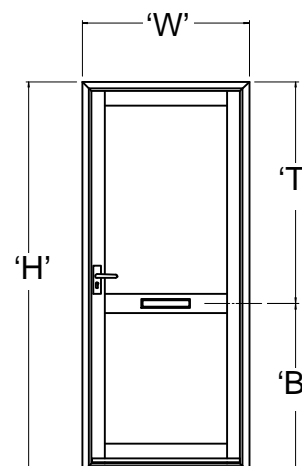

9.6 Threshold Machining Details

- Threshold Tray (Inward Opening)

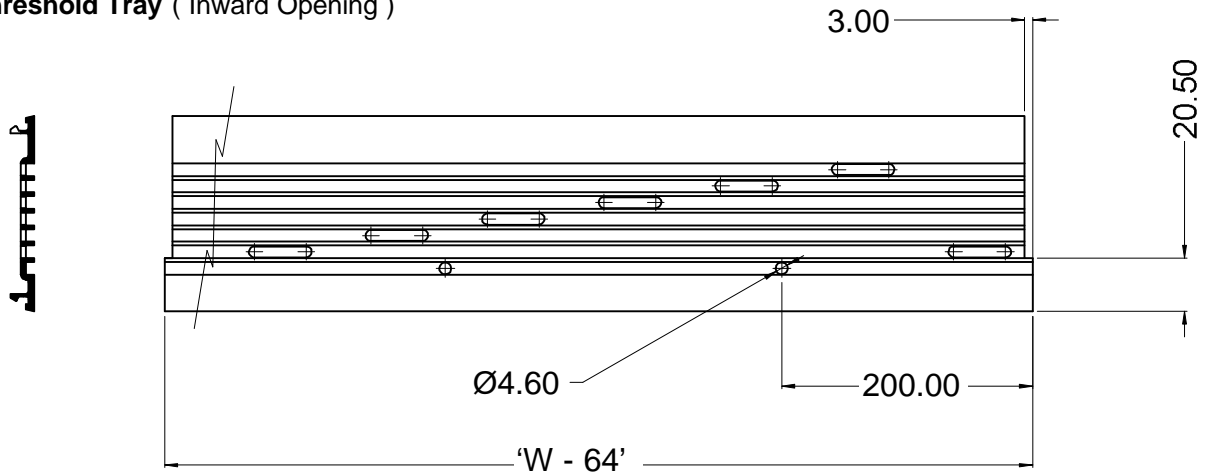

- Threshold Tray (Outward Opening)

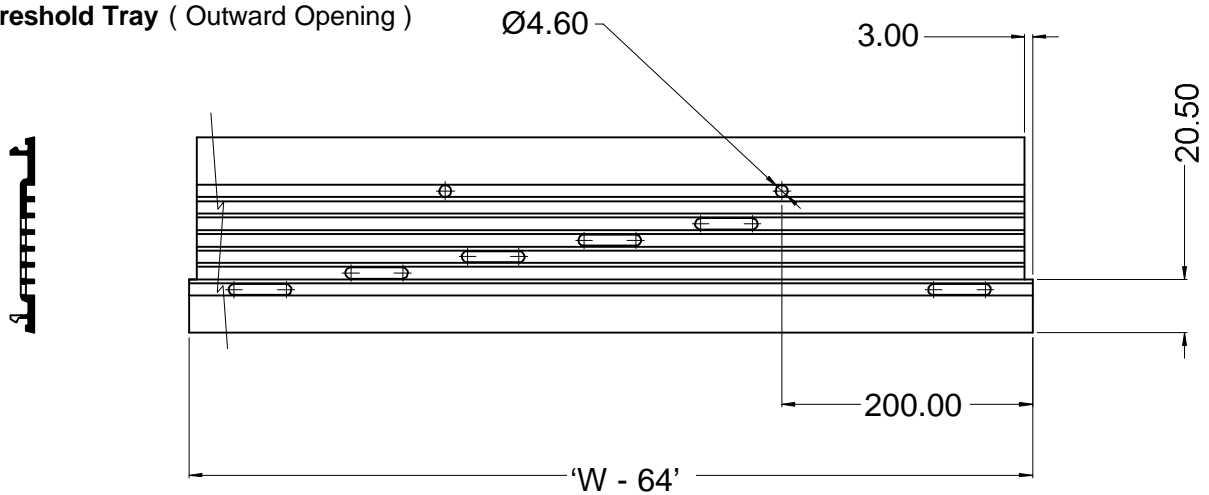

- Flipper Track

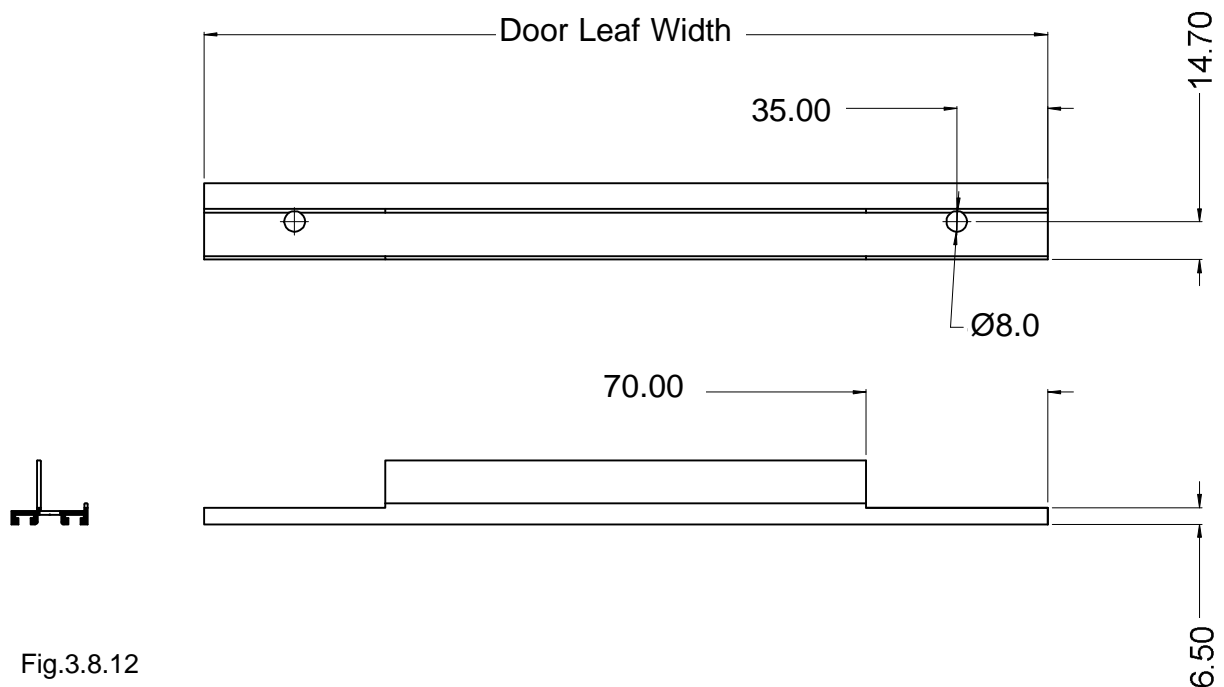

Fig.3.8.12

9.7 Assembly Details

Door Frame

- The jambs are supplied square cut, ready to sit down into the tracks on the tray. When a door frame is pre-assembled for delivery to site, the use of 'L' type brackets are required (C1692). Providing the jambs are securely fixed to the host wall or adjacent frames and the threshold base is fixed firmly to the floor, it is not necessary to use them.

- If the brackets are required drill 2 clearance holes at each end, $\text{Ø}4.20$ as per fig.3.8.13. Positioning the holes in the pre-prepared end of the track are as pictorially shown. The holes in the customer prepared opposite end, may vary in track location, so as to clear drainage slots.

- When fixing through the threshold base, liberally seal around any fixings to prevent water penetration.

- Fix the support brackets (C1692) to the track using the No.6 x 1/2" C'sk Hd Pozi flat end screws (ST612CPSS). Fig.3.8.14

- Slide the outerframe goal post down over the secured brackets. Drill $\text{Ø}3.80$ holes thro the jamb using the bracket holes as guides, fix thro from the inside of the jamb using No.6 x 3/8" Pan Hd Pozi screws (ST638PPSS). Fig.3.8.15 & 16.

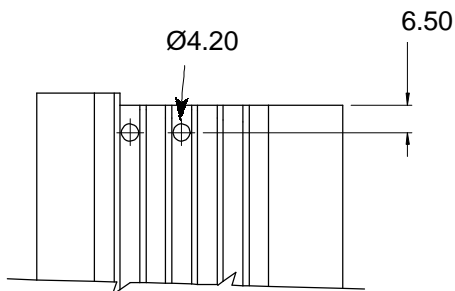

Fig.3.8.13

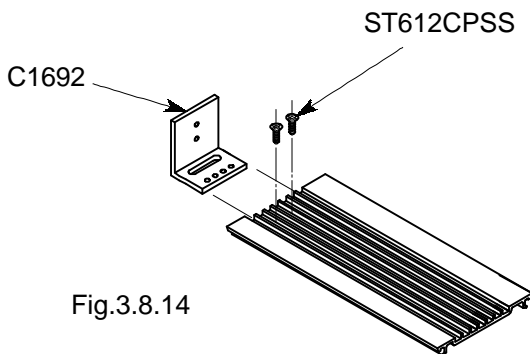

Fig.3.8.14

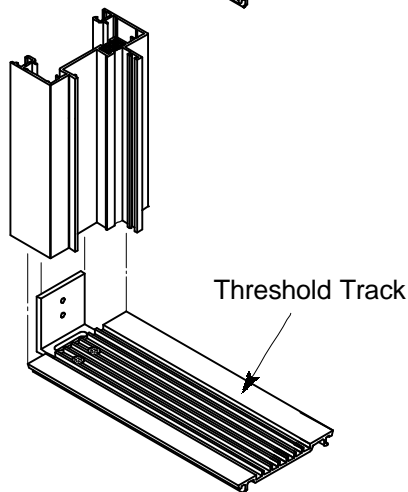

Fig.3.8.15

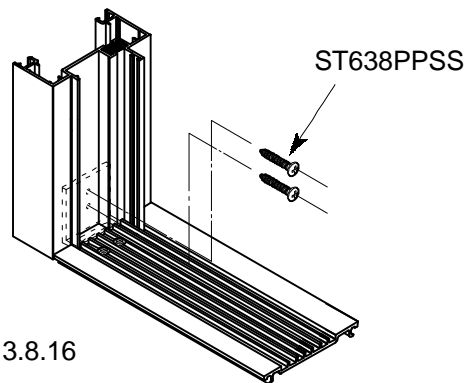

Fig.3.8.16

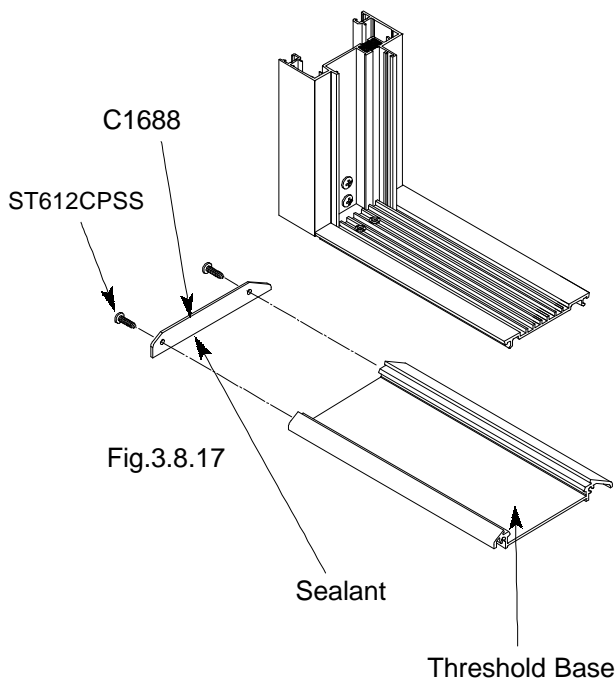

Fig.3.8.17

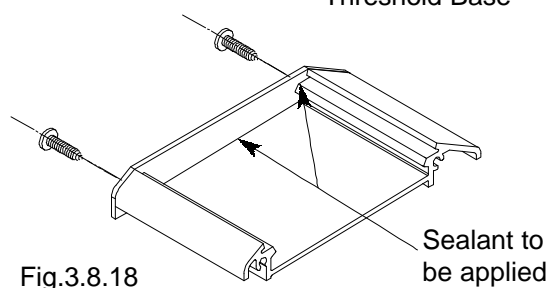

Fig.3.8.18

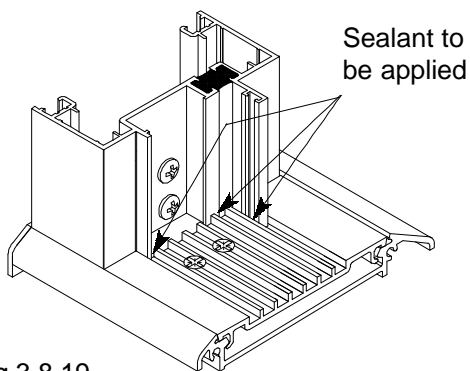

Fig.3.8.19

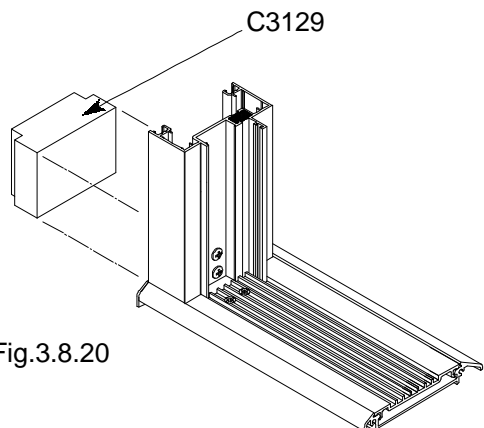

Fig.3.8.20

- If the end caps (C1688) have not already been fitted, apply sealant to threshold base end and fix the end caps using No.6 x 1/2" C'sk Hd Pozi screws (ST612CPSS).

- The end caps fixing holes will require counter sinking. The counter sink should be deep enough to ensure the fixing screw is flush with the end cap edge.

- Finish off by applying sealant around inside edge of base to end cap.(Fig.3.8.18)

- At this stage, please ensure orientation of door is correct. i.e the track to base relationship is correct. Base preps are always on the outside. Once the track is clipped down into the base it cannot be removed or repositioned without causing possible damage.

- Positioning the complete frame centrally to the base, it can now be push clipped down into the base. This may require applying a direct force. (Fig.3.8.17) Slip one leg of the track into the base prior to applying force.

- We advise that a block of wood or suitable alternative material be used to prevent any surface damage when applying the force.

- Seal around the jamb to track area as shown in Fig.3.8.19, and push fit a foam bung (C3129) down into the back of the jamb pocket.

- The bung should be positioned to sit level with the top edge of the base end cap, to allow for a small gap for water to drain away at the ends. Any gaps around the bung should then be filled with sealant to give a good watertight barrier.

Door Leaf

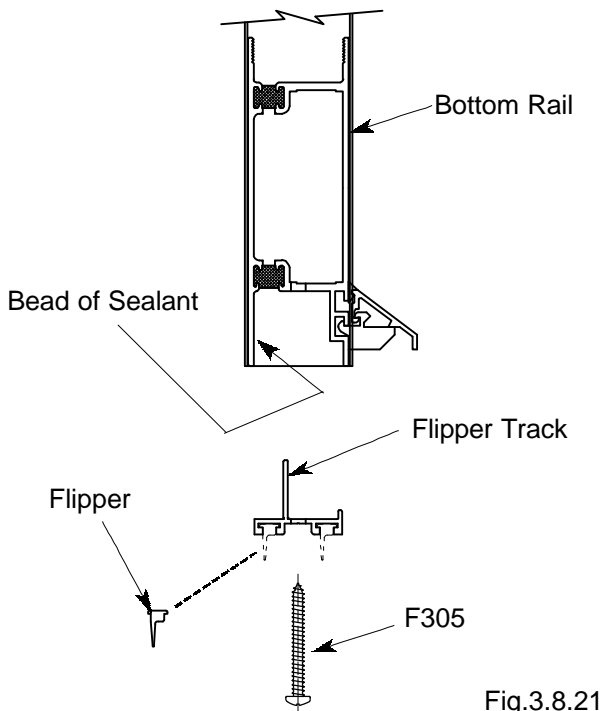

Fig.3.8.21

- Cut the kit down to its required size and prepare all threshold component ends where necessary.

- Assemble the door leaf in the normal way of butt fixing rails to stiles.

- Apply a liberal bead of sealant along full length of inner edge in bottom rail pocket. Check orientation of flipper track is correct (Refer to fig.3.8.22.) and slide track up into the rail pocket. This sealant should give a water proof seal with any excess sealant being cleaned off.

- Clamp the Flipper track up into the bottom rail pocket. Drill 4 holes, Ø3.50, equally spaced about the door leaf up thro' the track into the underside web of the bottom rail. Open up the holes in the track to Ø5.00 and fix both together with No.8 x 1½" Pan Pozi screws provided. (F305)

- For double door flush bolts, a clearance hole of Ø13mm must be made in the flipper tray on the slave/meeting leaf. Check the flush bolt operation is smooth and that no interference is caused between tray and bolt.

- Fit the flipper into the track, crimping the track ends to hold the flipper in place.

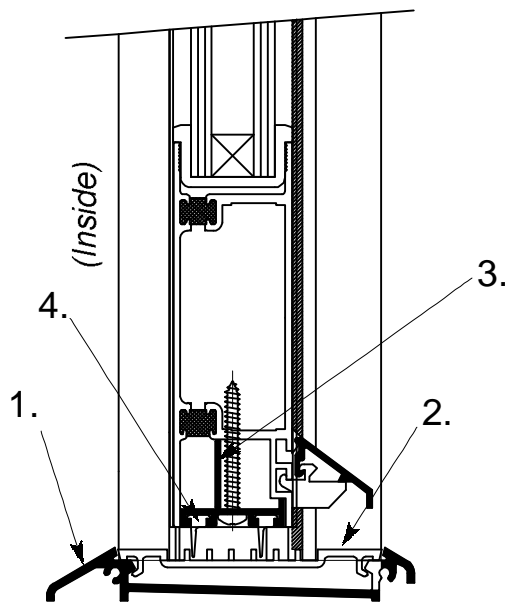

Inward Opening Sectional View

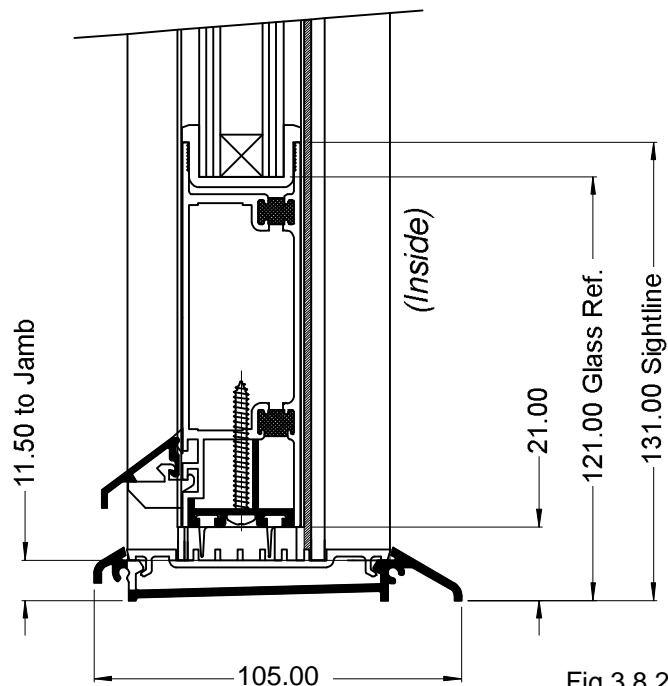

Fig.3.8.22

Outward Opening Sectional View

- 1. Threshold Base (M995 - Mill)
- 3. Flipper Track (M997 - Mill)

- 2. Threshold Tray (M996 - Mill)
- 4. Flipper (105/184)

Double Door Flush Bolts

- The top flush bolt on the slave/meeting stile is cut down, fitted and set up in the normal way. The retracted bolt end should be flush with the end of the stile. Once thrown, it will protrude out from the end by

- The bottom flush bolt is also fitted and set up in the normal way but an additional 2mm will require removing. The retracted bolt end should be 2mm up inside the stile and only protrude 16mm when thrown. This will prevent the thrown bolt fouling the threshold base as per fig.3.8.23

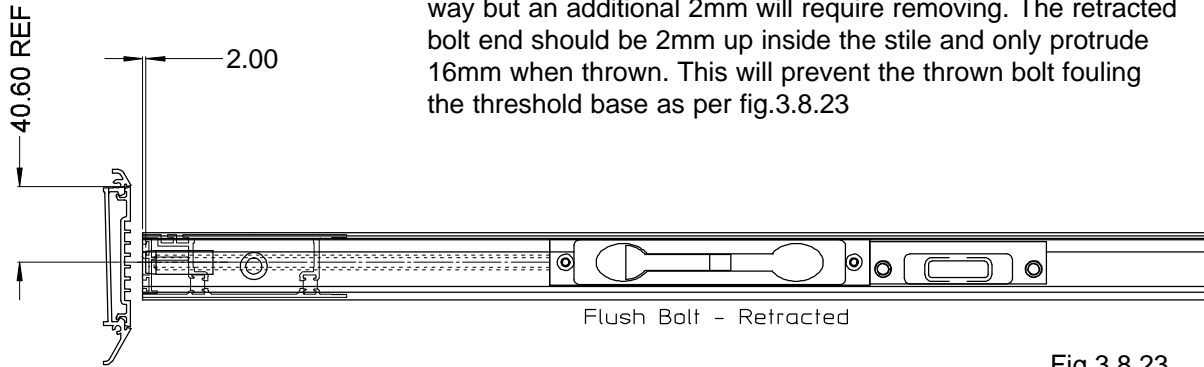
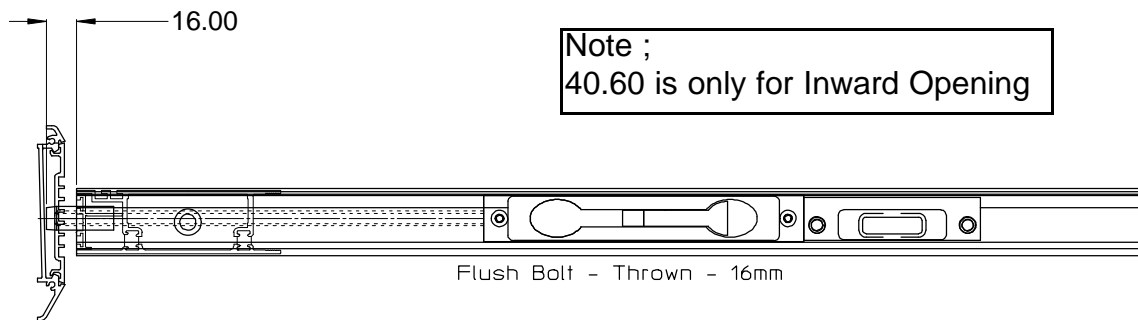

Fig.3.8.23



- Fig. 3.8.15 shows a general guide to key dimensions for setting up the flush bolt. Allowances should be made for variation of some components when installing, i.e. 6mm thread length into end guide.

- The doors can then be hung and the bottom flush bolt thrown to give an approximate position to drill a $\varnothing 13.00$ clearance hole. Before drilling check correct compression is achieved as per standard doors.

Only drill through threshold tray, DO NOT DRILL THROUGH BASE
- this will affect drainage causing water to penetrate onto the floor.

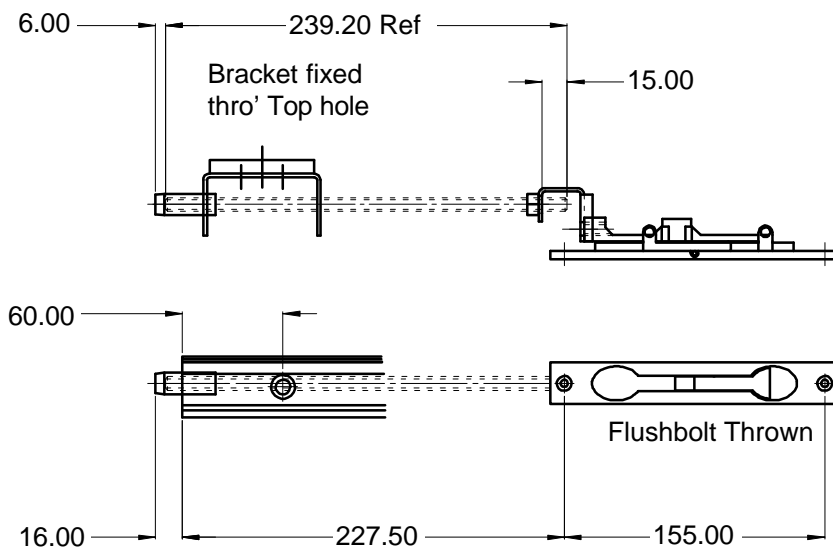

Fig.3.8.24

9.8 Additional Details

For all outward opening doors where the weather rated low threshold is used, it essential that a flipper seal is fixed to the external face at the top of the door. When this is fitted, the additional sealing method will guarantee the doors specified weather rating.

The carrier, flipper and fixings will be supplied as part of outward opening kits as standard.

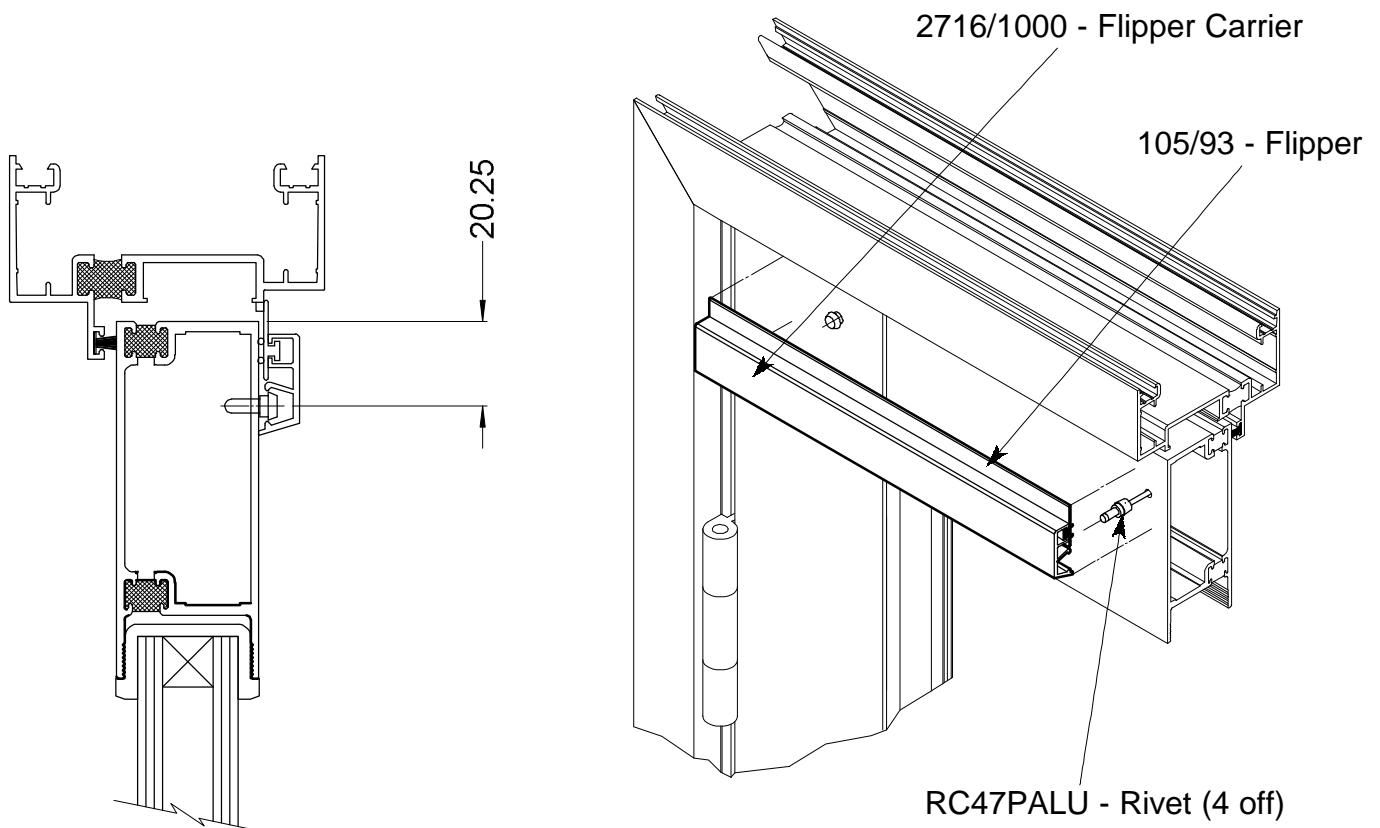

Fig.3.8.25

- Drill 4 holes $\text{Ø}4.2$, to suit the rivets, on the outer face of the door. Two positioned equally about the door leaf and one in each stile. They are to be positioned down 20.25mm from the top of each stile and top rail.
- Fix the 4 rivets, thro' the holes on the outer face of door leaf, using a suitable gun.
- Cut the Flipper Carrier and Flipper to a suitable length, and assemble by sliding flipper into carrier. The complete assembly should ideally cover the full width of door leaf, but may require to be cut short in some applications.
- Push and secure the complete Flipper Carrier assembly onto the mating rivet heads.
- A small bead of white silicone sealant, along the underside of carrier may be required to finish trim off.

10.0 Standard Low Threshold

10.1 Introduction

This Low Threshold Cill has been designed principally for use with both Monafame residential doors but may be used with woodfix doors. It provides an easy access option for wheelchair use and replaces the need to use the normal standard cill with upstand. ***It does not have a weather rating.***

The threshold components are only available in bar length.

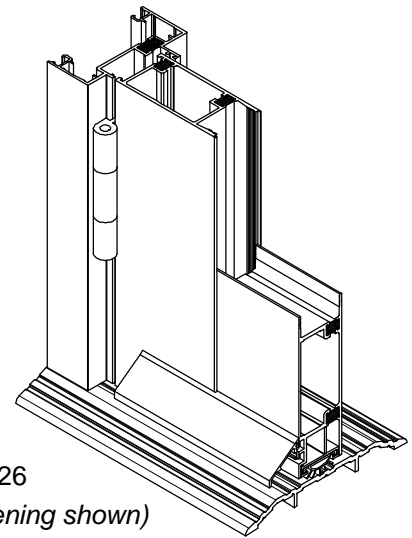

Fig.3.8.26
(Outward Opening shown)

10.2 Bar length Codes

Threshold (Mill)	3050mm	M998-3050M
Seal Carrier (Mill)	3050mm	M999-3050M
Hedgehog Seal	10 x 1M	A3255

10.3 Component Identification

- The Threshold is made up of 3 main components.

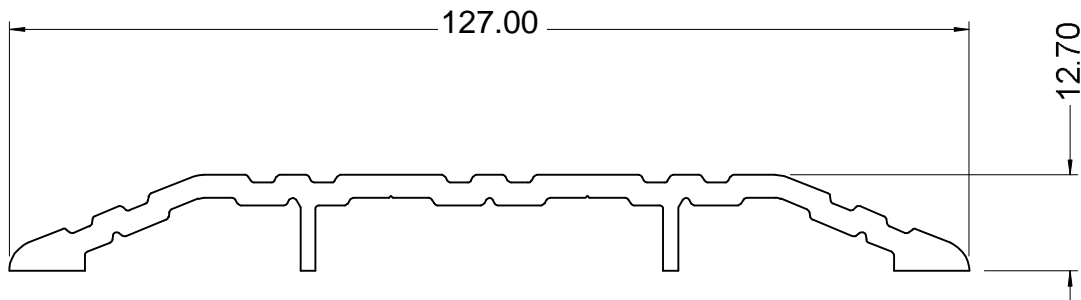

M998 - Threshold

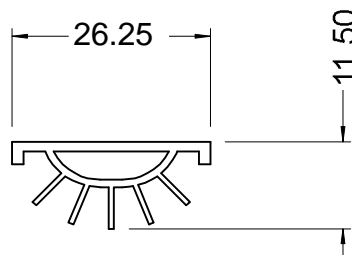

C3255 - Hedgehog Seal

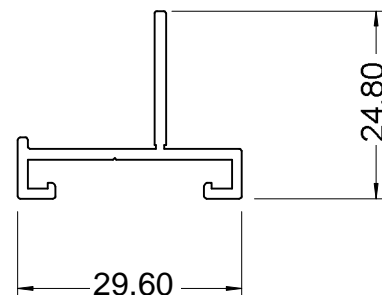

M999 - Seal Carrier

Fig.3.8.27

10.4 Component Measurements (Std Low Threshold)

- Where components are mitred or angle cut, dimensions are taken over the longer edge of the angle.
- All dimensions are in (mm). Formulae below are for where Monafame outer frame is used with the latest modified hinges - (C1529 'A4' - Ref Technical Bulletin TB1075D '2').
- Refer to Monarch Technical for Woodfix sizes.
- 'W' is the overall width of the outer frame and 'H' is the overall height of outer frame.
- Allowance for any clearance to brickwork must be considered when cutting kit components to final size.
- The minimum double door width cut down is 1090mm wide.

Component	Std Low Threshold	
	Single	Double
Head	W	W
Threshold	W	W
Jambs	H - 13	H - 13
Stiles	H - 57.5	H - 57.5
Rails (*See notes)	W - 235	$\frac{W - 392}{2}$
Seal Carrier	W - 79	$\frac{W - 85}{2}$
Weather Bar	Cut to Size	Cut to Size

(*) - Where double doors are cut down below 1450mm in width, it will be necessary to remove an extra 1mm from each rail width. This is to over come the reduced arc of the door leaf.
 i.e. **Rail length = (W-394)/2**

- For Cathedral Hinged doors, rail length for single doors is **(W-237)**. For double doors **(W-394)/2**.

10.5 Glass Formulae - to suit Standard Low Threshold

No Midrail				
	Width		Height	
	Single	Double	Single	Double
Low Threshold with Monaframe	W - 215	$\frac{(W - 352)}{2}$	H - 232	H - 232
Low Threshold with Woodfix	W - 169	$\frac{(W - 304)}{2}$	H - 210	H - 210

With 'A' Type Midrail (Std Height)				
	Width		Height	
	Single	Double	Single	Double
Top - LT with Monaframe Btm - LT with Monaframe	W - 215	$\frac{(W - 352)}{2}$	H - 1027 715	H - 1027 715
Top - LT with Woodfix Btm - LT with Woodfix	W - 169	$\frac{(W - 304)}{2}$	H - 1005 715	H - 1005 715

With 'B' Type Midrail (Std Height)				
	Width		Height	
	Single	Double	Single	Double
Top - LT with Monaframe Btm - LT with Monaframe	W - 215	$\frac{(W - 352)}{2}$	H - 997 598	H - 997 598
Top - LT with Woodfix Btm - LT with Woodfix	W - 169	$\frac{(W - 304)}{2}$	H - 975 598	H - 975 598

Std Height 'Dim B' = 872.70 for A Type Mid rail
 = 799.20 for B Type Mid rail

Important Note ;

Where double doors are below 1450mm in width, it will be necessary to remove an extra 1mm from the glass width.

i.e. **Glass Width = (W-354)/2**

- For Cathedral Hinged doors, glass width for single doors is **(W-217)**.
 For double doors **(W-354)/2**.

- All dimensions are in millimetres.

- Midrail Height 'B' from underside of threshold to centre line of rail.

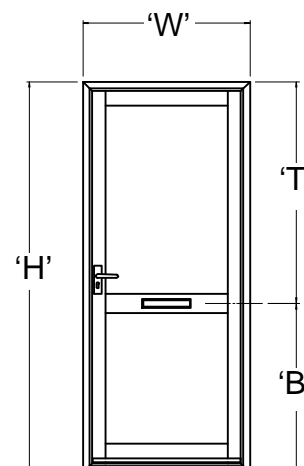

10.6 Machining Details

- Lock and Hinge Stile (Also Meeting Stile for Double Doors)

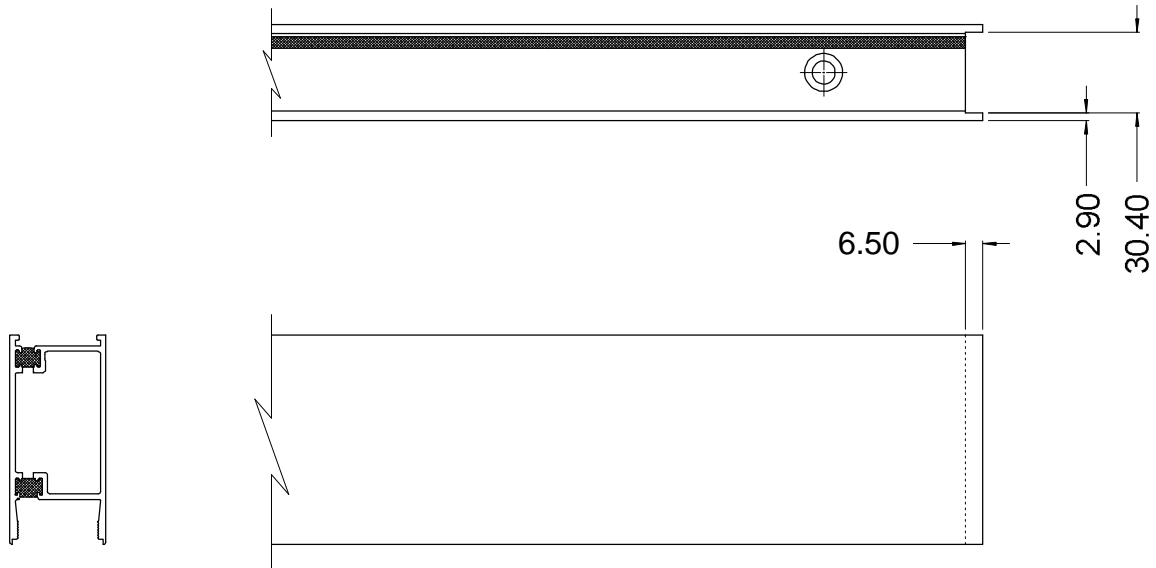

- Seal Carrier

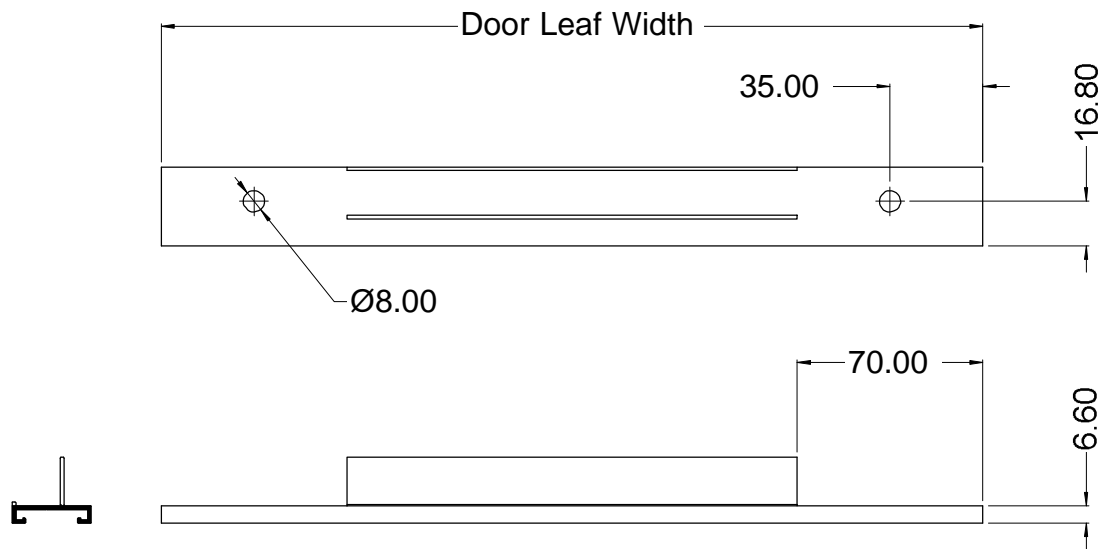

Fig.3.8.28

- The threshold is straight cut with no additional preps.

10.7 Assembly Details

Door Frame

- The jambs are supplied square cut ready to sit down onto the threshold. When a door frame is pre-assembled for delivery to site, it is suggested that suitable 'L' type brackets are used to secure the jambs down to the threshold. Providing the jambs are securely fixed to the host wall or adjacent frames and the threshold is fixed firmly to the floor, it will not be necessary to use them.

- After the frame has been installed make sure the jamb to threshold joints are carefully sealed with silicone to prevent water tracking under the jambs into the brickwork. Seal all around outer frame as per the normal standard methods.

Door Leaf

- Once all the components have been cut to size using the formulae cutting chart, assemble the door leaf in the normal method of butt fixing rails to stiles. Refer also to machining details.

- Apply a liberal bead of sealant along full length of inner edge in bottom rail pocket. Check orientation of seal carrier is correct (Refer to fig.3.8.29) and slide carrier up into the rail pocket. This sealant should give a water proof seal with any excess sealant being cleaned off.

- Clamp the seal carrier up into the bottom rail pocket. Drill 4 holes, $\text{Ø}3.50$, equally spaced about the door leaf up thro' the track into the underside web of the bottom rail. Open up the holes in the track to $\text{Ø}5.00$ and fix both together with No.8 x $1\frac{1}{2}$ " Pan Pozi screws provided. (F305)

- For double door flush bolts, a clearance hole of $\text{Ø}13\text{mm}$ must be made in the seal carrier on the slave/meeting leaf. Check the flush bolt operation is smooth and that no interference is caused between carrier and bolt.

- Fit the hedgehog seal into the carrier, crimping the track ends to hold the flipper in place.

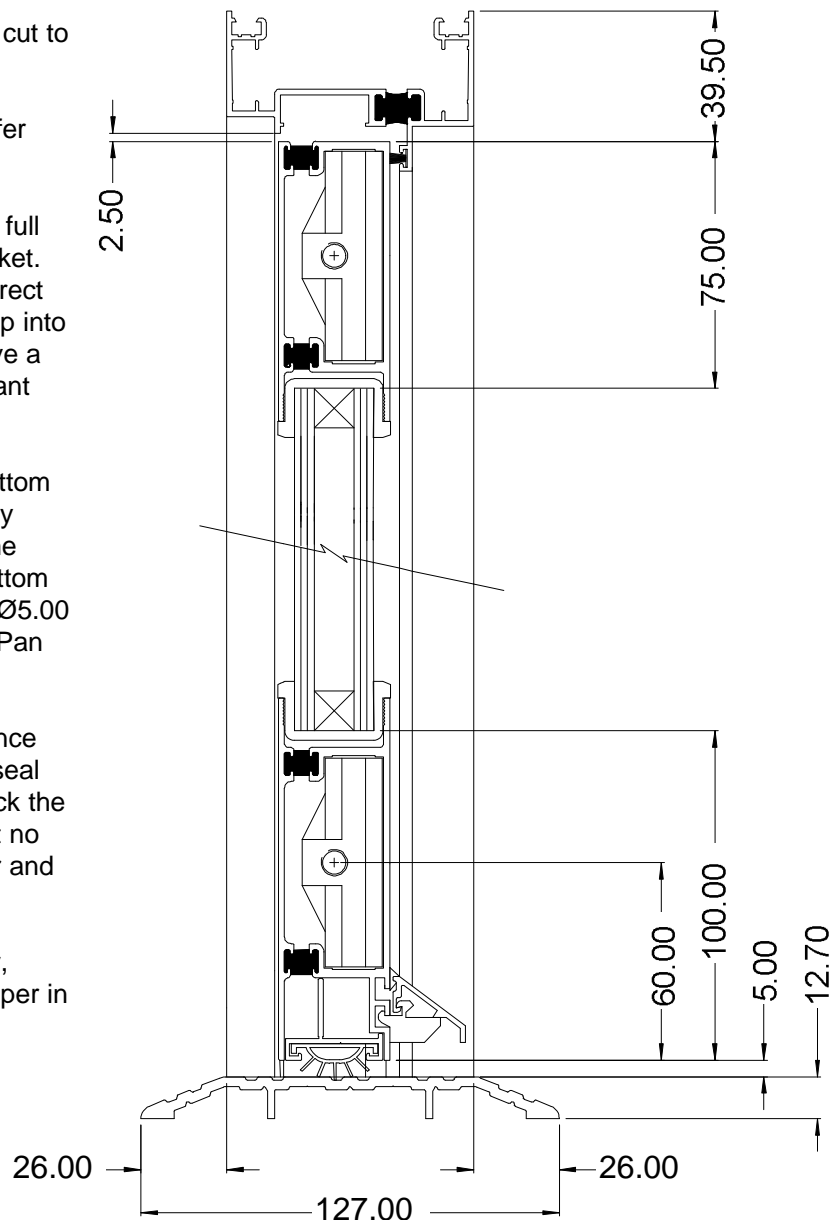

Fig.3.8.29