

312

50 mm

Curtain Wall

Index

	Page No.	Last Issue Date
Additional Specialist Profiles & Bulletins 107, 115, 118, 119, 120, 132,138,143,146A, 150,155,162A, 175, 176, 177 & 196		12.93
Specification	3	05.88
General Arrangement	4&5	07.92
Vertical Glazing	6	10.88
Sloping Glazing	7	05.88
Mullion Jointing and Fixing	8	05.88
'Hung' Condition	9	0688
'Prop' Condition		
Mullion Assemblies	10&11	05.88
Corner Details & Rail Assemblies	12&13	0688
Opening Light Assemblies	14	07.92
Ridge & Roof Rail Assemblies	15	0688
Eaves Assembly	16&17	05.88
Glazing Variations	18	0688
Parts List	19	07.92
	20&21	05.88
Sealants	22	10.88
Strength Calculations	23&24	05.88
	25	06.92
Range of Inertia Values	26	05.88
Guidance Notes	27	06.92
	28	05.88
Workshop Data	29	0688
Preparation of Mullions	30&31	05.88
	32	0688
Corner Adaptor & Mullion/Ridge Relationship	33	05.88
Rails & Clamp Plates	33&34	05.88
Sub Cill & Cappings	35	0688
Cappings	36	05.88
Roof Rails & Ridge	36	05.88
	37	06.92
Eaves Lining, Gutter and Sleeve	38	05.88
Roof Vent and Adaptor	39	05.88

Index (continued)

	Page No.	Last Issue Date
Assembly		
Vertical and Sloping Mullions	41	05.88
Vertical and Sloping Mullions	42	06.92
Rails for Vertical and Sloping Glazing	43	05.88
Roof Ventilator & Ridge Assembly	43 & 44	05.88
Installation		
Sub Cill	47	0688
Mullion & Rails in Vertical Glazing	47 & 48	0688
Ridge & Mullions in Sloping Glazing	48	0688
Roof Rail	49	05.88
Preparation for Glazing	49	05.88
Glazing	50	05.88
Application of Cappings	50	05.88
Application of Ridge Capping and Gutter	51	0688
Gutter Outlets and Downpipes	52	0588



312 50mm CURTAIN WALLING

Additional Specialised Profiles

1st JULY 1989

312 ADDITIONAL SPECIALISED PROFILES

WE ARE INTRODUCING A NUMBER OF NEW PROFILES WHICH HAVE BEEN SPECIFICALLY DESIGNED TO CATER FOR SOME OF THE SPECIAL CONDITIONS MET IN VERTICAL AND SLOPING CURTAIN WALLING

THIS, AND THE FOLLOWING PAGES, GIVE DETAILS OF THE PROFILES, NOTES OF THEIR USE AND TYPICAL APPLICATIONS WHICH SHOULD BE READ IN CONJUNCTION WITH THE 312-MANUAL.

THE ALUMINIUM PROFILES DETAILED BELOW ARE HALF FULL SIZE. THE GASKETS ARE FULL SIZE:-

ALUMINIUM PROFILES

PART No	DESCRIPTION
17172	VALLEY GUTTER
17173	VALLEY LINER
17190	80mm CLAMP PLATE
17191	INSERT ADAPTOR
17192	APEX BOSS
17193	CAPPING
17194	EAVES RAIL
17195	HEAD

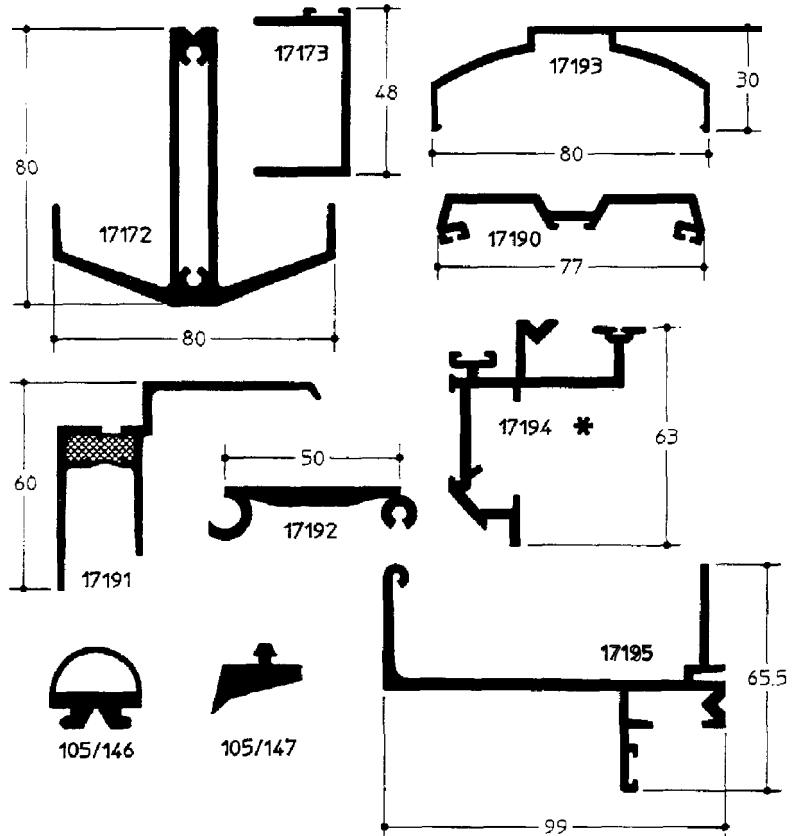

GASKETS

105/146	INNER BULB SEAL
105/147	ANGLED OUTER GASKET



COMPONENTS

312/38	80mm CLAMP PLATE IS SUPPLIED AS A PRE-PUNCHED COMPONENT 6100mm LONG FROM PROFILE 17190.
312/35	EAVES RAIL BRACKET (90° CONDITION)
312/36	APEX BOSS BRACKET

NOTE : WHEN USED TO PROVIDE VENTILATION, PROFILE 17194 CAN BE PROVIDED PRE-SLOTTED AND FITTED WITH INSECT MESH AND CONTROL SLIDE, TO ORDER.

SLOPING VALLEY GUTTER ASSEMBLY

NOTE : THIS DETAIL INDICATES TYPICAL ASSEMBLY WITH NEAR MAXIMUM ANGLE. SHALLOWER ANGLES CAN BE ACCOMMODATED BY ADJUSTING RELATIONSHIPS

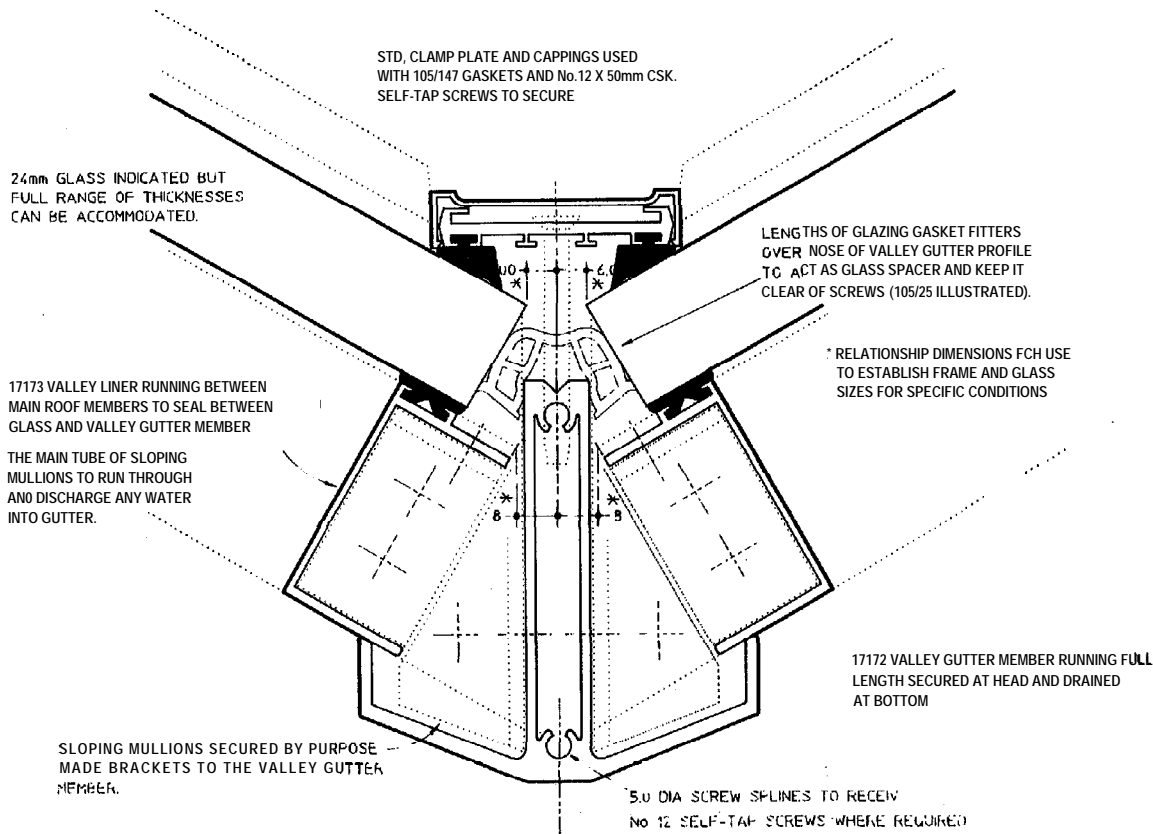

EAVES JUNCTION WITH DIFFERING VERTICAL AND SLOPING MULLION CONDITIONS

(NON-VENTED CONDITION WITHOUT GUTTER)

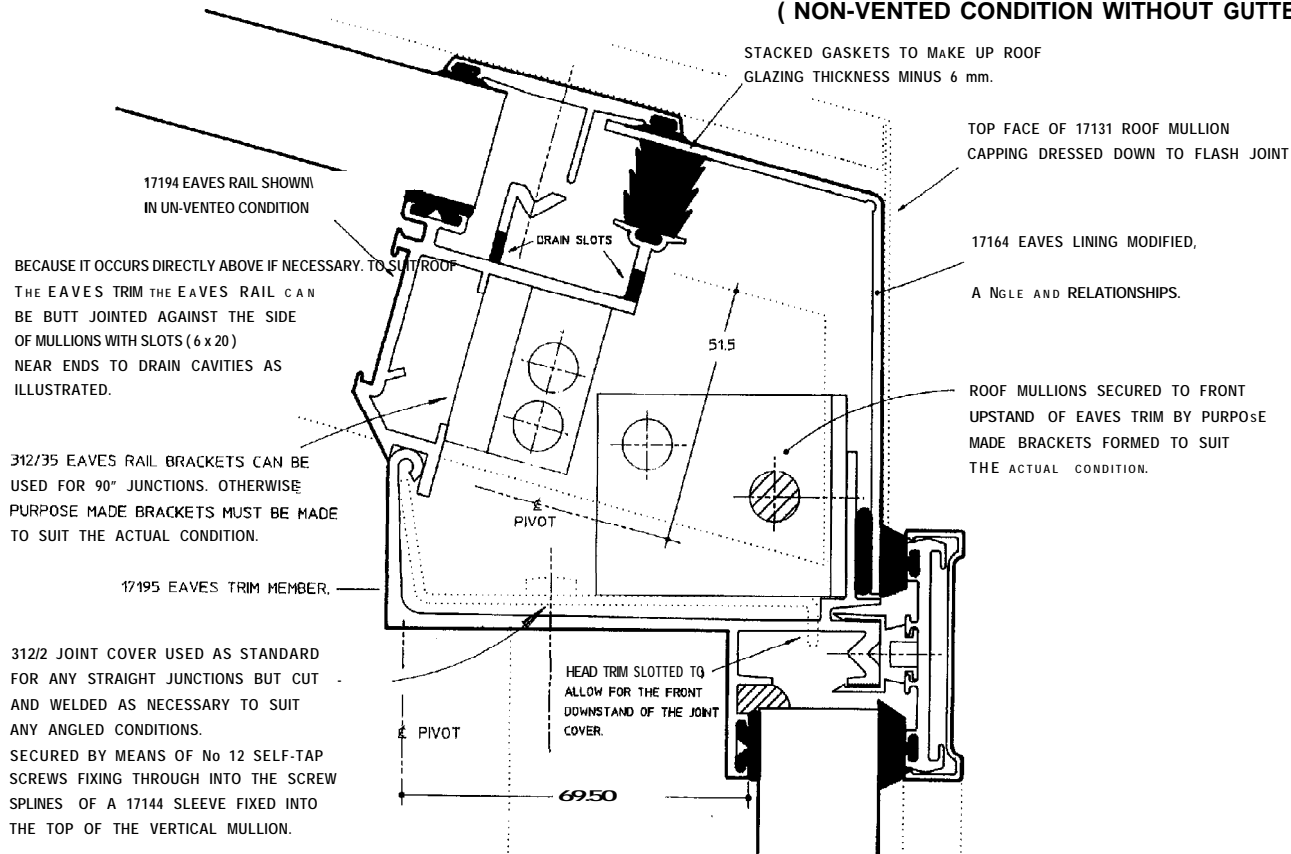

APEX CONNECTING BOSS ASSEMBLY

THIS PROFILE INTERLOCKS ONTO ITSELF AND ALLOWS ALMOST ANY CONFIGURATION OF APEX BOSS TO BE FORMED.

THE FINAL SHAPE IS THEN CAPPED AT TOP AND BOTTOM BY PURPOSE MADE 10 GAUGE ALUMINIUM PLATES SECURED AT EACH SCREW SPACING BY No 12 x 13mm SELF-TAP SCREWS.

TYPICAL HALF FULL SIZE DETAILS GIVEN BELOW.

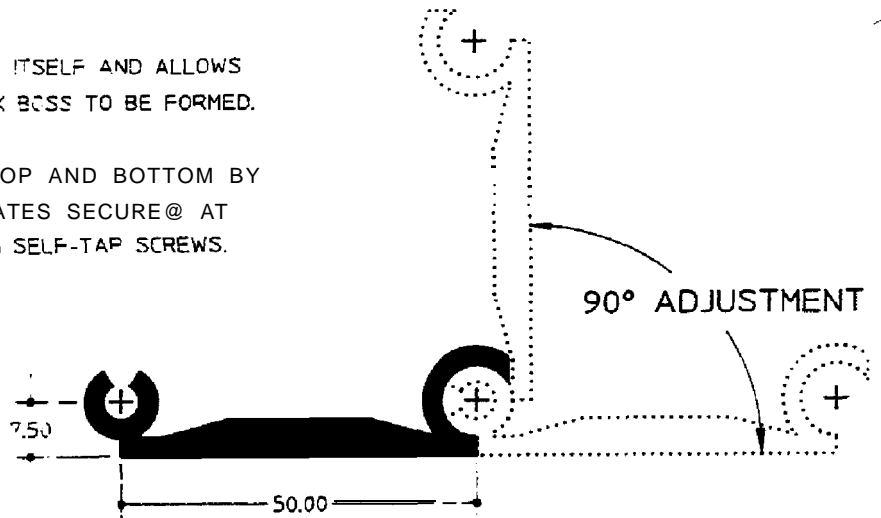

THE COMPLETED APEX ASSEMBLY WILL FORM A SOLID BASE FOR ANY FORM OF VISUAL CAPPING REQUIRED.

THE HEIGHT OF THE APEX BOSS MUST BE SUFFICIENT TO RECEIVE THE MULLION DEPTH AT THE ROOF ANGLE CONCERNED

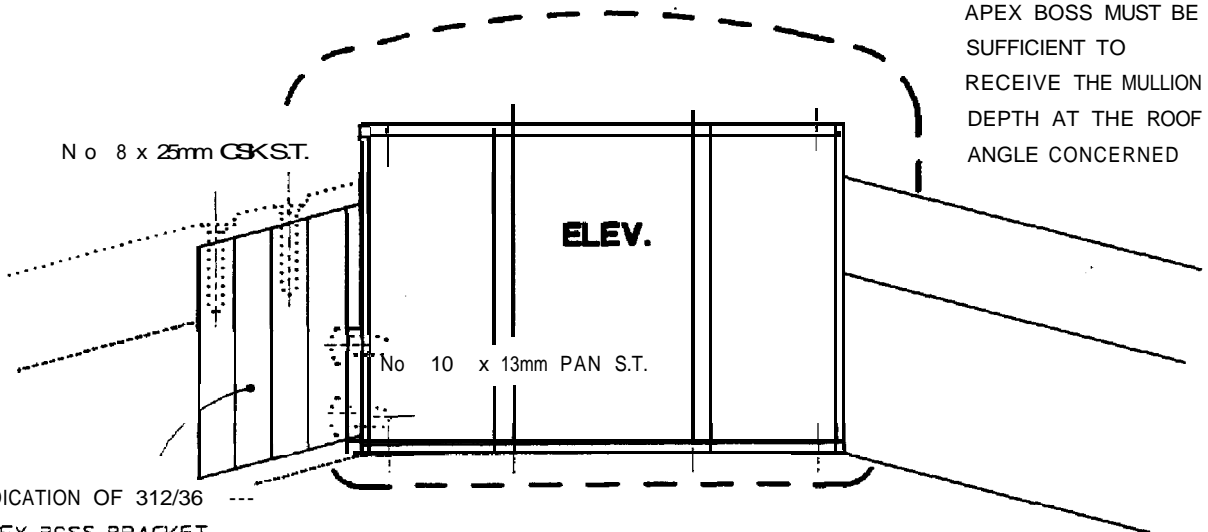

INDICATION OF 312/36 APEX BOSS BRACKET SECURING ROOF MULLIONS TO BOSS SEGMENT.

IN ITS STANDARD FORM THIS BRACKET DIRECTLY SUITS A 15° SLOPE BUT THE TOP SURFACE WILL NEED TO BE CUT TO SUIT ANY OTHER ANGLE

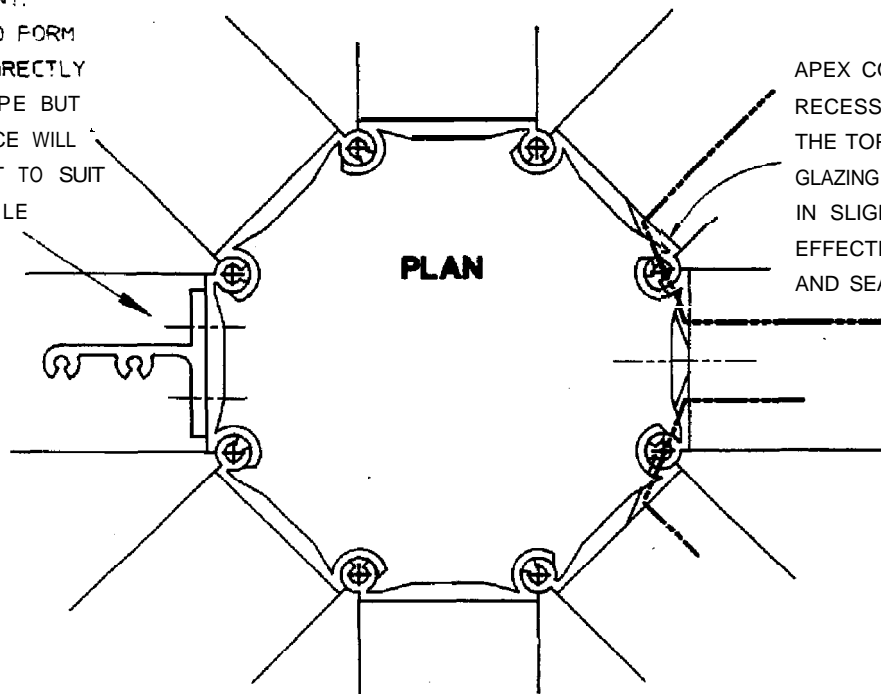

APEX CORNERS MUST BE RECESSED TO ALLOW THE TOP CORNER OF GLAZING TO RECESS IN SLIGHTLY TO ALLOW EFFECTIVE SEATING AND SEALING.

WIDE CAPPING TO ACCOMMODATE VARYING 24mm GLAZING ANGLES

(90° DOWN TO 60° RELATIVE TO THE CENTRE LINE OF MULLION)

MULLION 17107 IS SHOWN BUT
THIS ARRANGEMENT APPLIES
EQUALLY TO THE FULL RANGE
OF MULLIONS.
IT CAN ALSO BE USED FOR BOTH
VERTICAL AND SLOPING GLAZING.

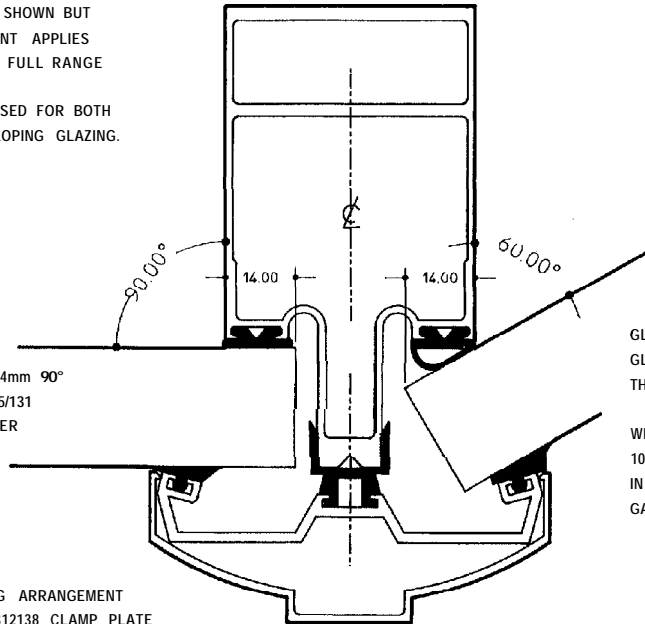

GLAZING GASKETS ON 24mm 90°
GLAZING SHOULD BE 105/131
INNER AND 105/136 OUTER

OUTER CLAMPING ARRANGEMENT
FORMED FROM 312138 CLAMP PLATE
WITH 17152 15mm) LOCATION SPACER
AND 17193 CAPPING

GLAZING GASKETS ON 24mm ANGLED
GLAZING MUST BE VARIED TO SUIT
THE ACTUAL CONDITION

WE WOULD SUGGEST THAT THE
1051146 INNER BULB SEAL IS USED
IN ALL CASES WITH THE OUTER
GASKET BEING VARIED AS FOLLOWS :-
105/147 FROM 60° TO 69°
105/133 FROM 70° TO 84°
1051136 FROM 85° UPWARDS.

FITTING OF TYPICAL OPENING LIGHT INSERTS INTO ANGLED MULLIONS

NOTE THAT THE ANGLED
MULLION MUST BE 17102
OR LARGER TO ACCOMMODATE
THE ADAPTOR PROFILE.

THE SPECIAL ADAPTOR PROFILE ALLOWS
ANGLED GLAZING DOWN TO 60° FROM THE
MULLION CENTRE LINE.

FOR GREATER ANGLES THE ADAPTOR LEGS
WILL NEED TO BE SHORTENED AS NECESSARY.

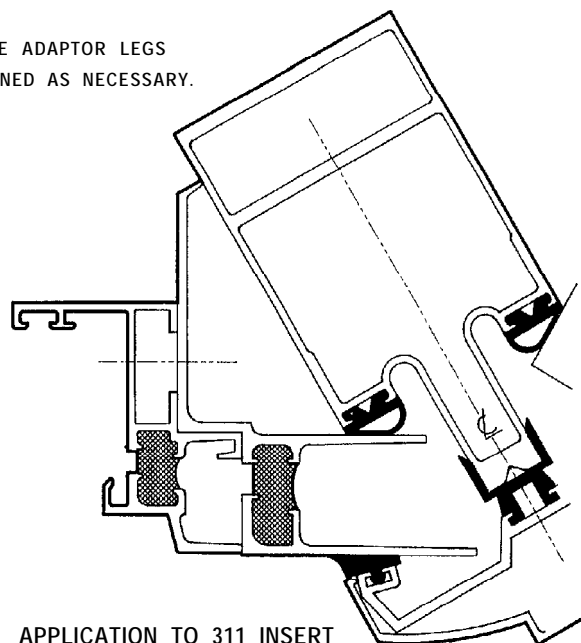
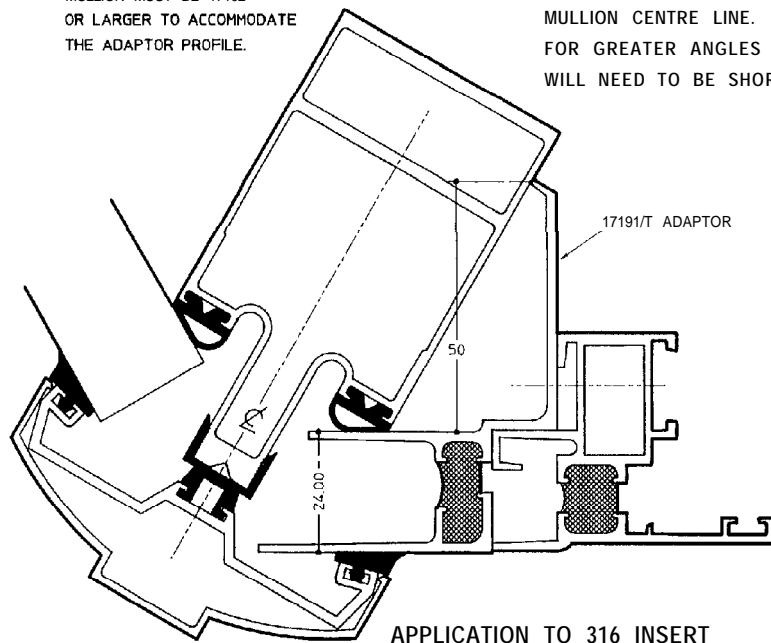

Please **circulate to all personnel who should be informed.**

312 (50mm) Curtain Wall.

Two additional profiles are now included in this range to increase the options available.

17114 is an Adaptor profile which, when applied to transom rails 17110 or 17111, gives the same basic shape as mullion 17101 so that the cappings on both will then line through - this allows a flush inner face to be achieved when necessary.

17139 is a squared off version of the existing 17136 Capping and it can be used in the same manner and gives the same strength values.

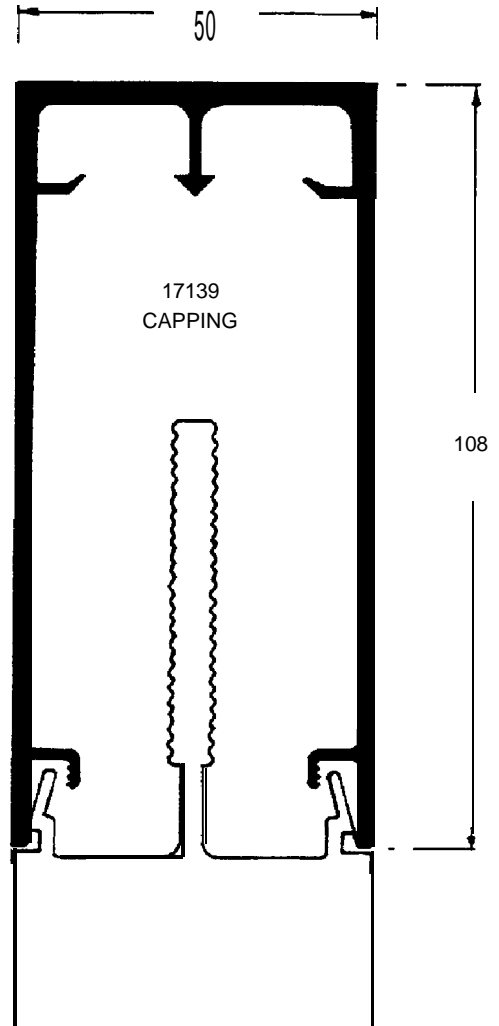
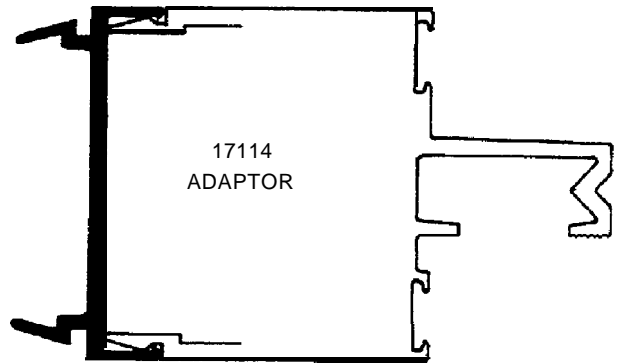

Date 1st JULY 1989

General Bulletin

No. 115

312 CURTAIN WALL

ADDITIONAL CAPPING PROFILES

The basic inner capping for rail members is 17131 (10mm) which lines through with the back face of the basic 17100 mullion, but we are now introducing 3 additional cappings which will line through with the larger box profiles 17102, 17103 & 17104.

In addition to their use as inner rail cappings, all these profiles can also be used as outer feature cappings, *on* both mullions and/or rails, whilst 17129 can be used as a squared off alternative to 17135 to cover the serrated inner flange of the 17101 mullion.

Wind loading inertia values for these cappings are:-

17128	1 4,579mm ⁴
17129	259,364mm ⁴
17132	83,709mm ⁴

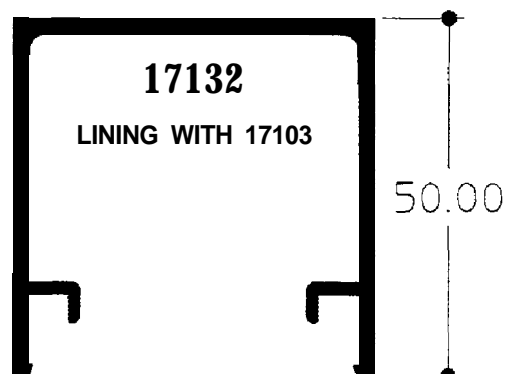
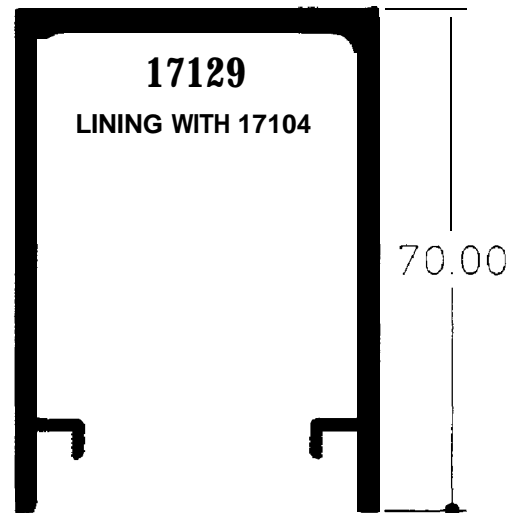
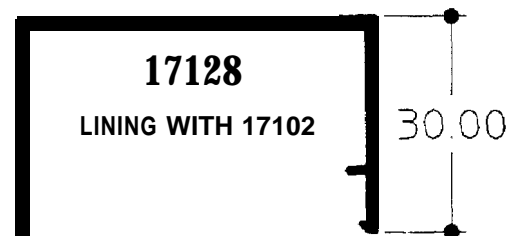

Date 1 Ith September 1989

General Bulletin

No. 118

312 CURTAIN WALL

ADDITIONAL PROFILES

An additional mullion capping 17127 is being introduced which is a Rush face version of the existing 17133.

This profile will provide the slight step (2 mm) between basic cappings at mullion/rail junctions while still maintaining the plain flat surface.

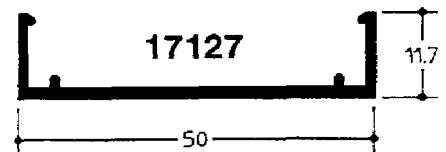

A new clip profile 17143 is also introduced which will provide additional retention when feature cappings are fitted to mullion or rail clamp plates. Without additional retention these cappings are too easily dislodged because of the leverage resulting from their projection.

This profile is provided in 3000 mm lengths, mill finish only, and should be cut into small pieces (approximately 30 mm) and clipped into place at 200 mm centres on the fitted clamp plate. A small bead of silicone, or simitar, should be applied to the legs of each clip to ensure that they do not slide down the mullion.

When the feature capping is fitted, the spring dip engages onto the capping shoulders and holds it securely in place.

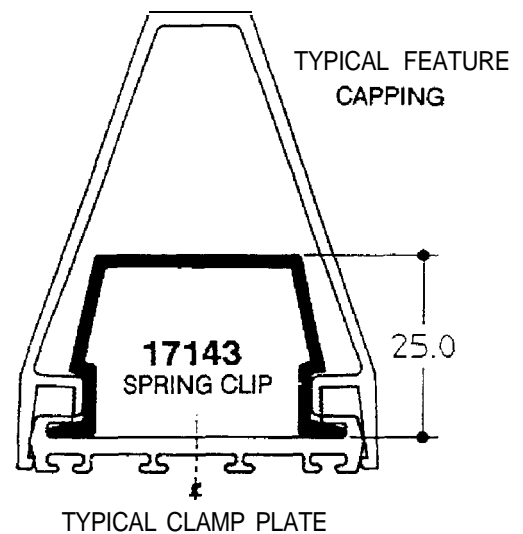

- * Please note this Bulletin replaces the original issue dated 28th August, 1989.
 (Additional note regarding silicone added Para 2 - 17143)

Date 11 th September 1989

General Bulletin

No. 119

312 CURTAIN WALL

ADDITIONAL MULLION PROFILE 17104

The mullion range is being extended by the introduction of a deeper (134 mm) box mullion, as illustrated.

The lower (front) box shaping relates exactly to all other existing mullions the only variation being the upper (back) extension.

The wind loading inertia value for this new mullion in combination with the basic 312/1 8 clamp plate is 2,000,000 mm⁴

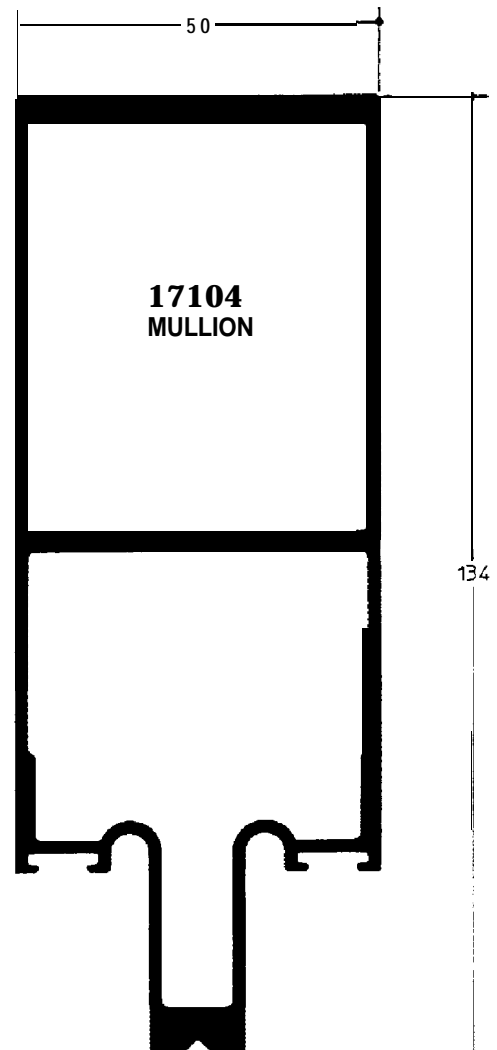

** Please note this Bulletin replaces the original issue dated 23th August, 7989 (Change to dimension stated in Para 1)

Date 28th August 1989

General Bulletin

No. 120

312 CURTAIN WALL

312 CURTAIN WALL STANDARD FIXING BRACKETS

314/16 standard fixing bracket already exists for use with mullion 17101, but with the increasing use of rectangular box mullions we are now introducing an additional bracket 312/15 for use with that type of mullion.

This new bracket is prepared with two 13 mm diameter holes A, two 9 mm x 38 mm slots B and eight 9 mm diameter holes C.

The holes A are for M12, or similar, bolts securing the bracket to the building structure. Ideally these should fix to 'Unistrut' or 'Halfen' type cast in channel inserts to allow sideways adjustment.

The slots B are to allow for first stage fixing of the box mullion with M8 screws to allow for 30 mm of in/out adjustment in the mullion position.

The holes C offer alternative positions for the remaining two M8 screw for which the mullion should be drilled only after final lining up so that they lock the mullion in its correct position. The holes which avoid clashing with mullion flanges should be used.

The set screws/bolts to be used at B and C should be M8 x 90 mm hex HD, with washers and lock nut, all in class 300 'A2' stainless steel.

Provided the fixing to structure is adequate this bracket will safely support 6.5 kn wind load and 9.7 kn dead load (allowing a safety factor of 2).

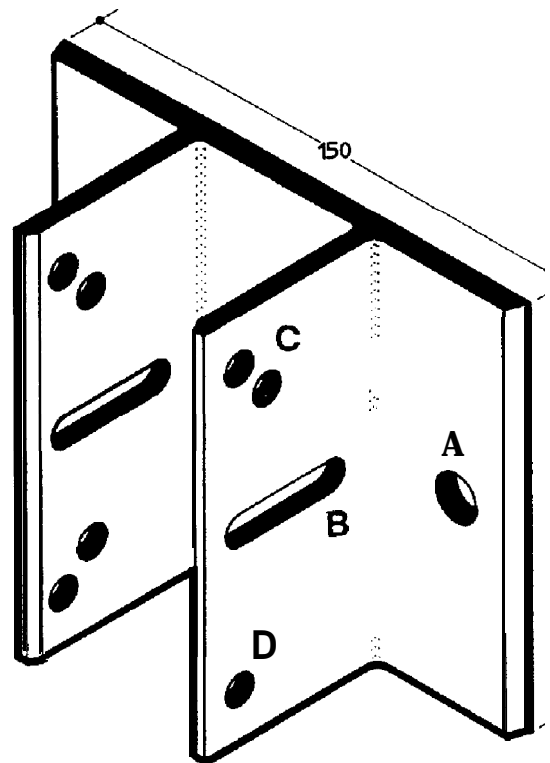

312/15 BRACKET



Date 24th January 1990

General Bulletin

No. 132

312 CURTAIN WALL

RAIL FLASHING FOR DOUBLE GLAZING - DUAL HARDNESS PVC PROFILE 17155

In some cases the manufacturers of double glazed units are not prepared to maintain their guarantees if water is allowed to get onto the top surface of their units, no matter how little or for how short a time.

In our 312 curtain walling, as with any other drained system, it is possible that drops of water could lodge for a short period so we are now introducing a special rail flashing, 17155, which will pick up and drain any water which is in this area.

When this flashing is used it will also allow the bead of silicone detailed in manual note 5.25 to be omitted.

The flashing profile is square cut to length (mullion centres minus 18mm) and is then inserted into the underside of each rail and centralised so that it does not block the fitting of mullion clamp plate spacers. The double glazing below can then be inserted and should be packed up to make contact with the front nose of the flashing.

The flashing should always be used in unbroken lengths wherever possible, but if a joint cannot be avoided, the void above the joint must be filled with silicone to prevent any water overflow at the joint.

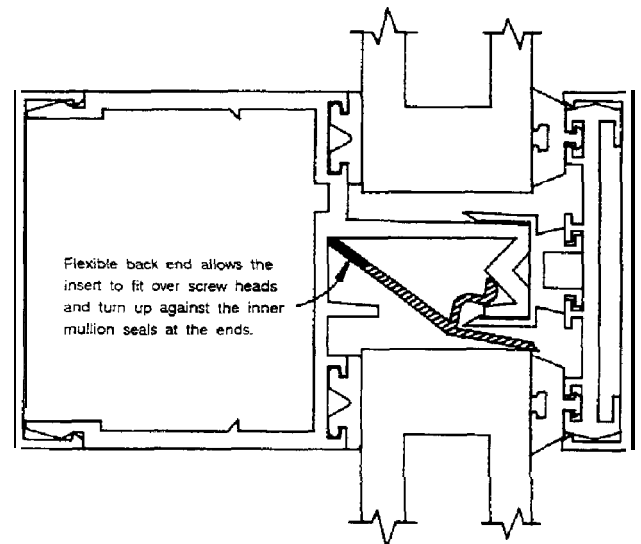

Typical Application

RECOMMENDATION: To avoid any dispute over any double glazed units which may fail, we would advise that this new rail flashing should be used as a standard wherever double glazing is fitted.

Date 19th March 1990

General Bulletin

No. 138

312 CURTAIN WALL

INTERMEDIATE DRAINAGE MOULDINGS 312/31,32 & 312/31,32 & 33

This is a fully pressure equalised rain screen form of construction which allows any water which may get past the outer baffles to drain safely down to the su-cill, which in turn drains it back to the outside.

To avoid the danger of any excessive build up of this draining water on tail applications, we are now introducing a range of mouldings which can be applied to the nose of mullions to collect and drain this water at intermediate points. These mouldings should be fitted **in vertical mullions only** where vertical, or vertical and sloping mullion runs exceed 6 metres. Three types are available, with nose extensions to match the thickness of the clamp plate location spacers, and they are colour coded in a similar way:-

312/31 - Black -to suit the 1 mm location spacer 17150

312/32 -White-to suit the 5mm location spacer 17152

312/33 - Grey - to suit the 9mm location spacer 17153

Where used, these drainage mouldings must be positioned immediately below the 13mm Dia outlet holes in the mullion nose above mullion joints.

They are sealed onto the mullion nose through prepared square holes (27 x 27) in the clamp plate after glazing, and outlets are provided in the sides of clamp plate and capping as detailed overleaf.

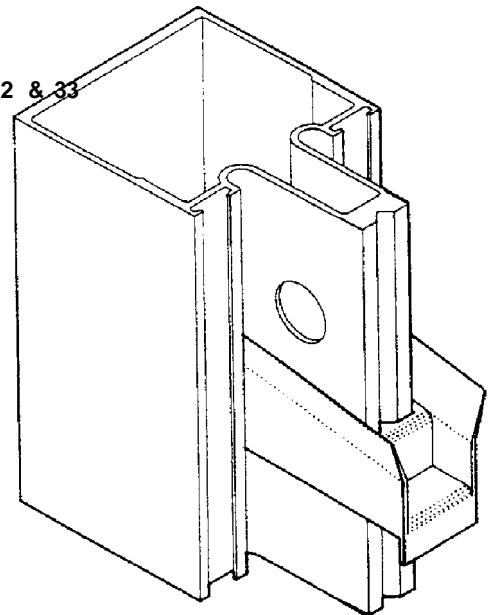

(not to scale)

TYPICAL APPLICATION OF INTERMEDIATE DRAIN MOULDING

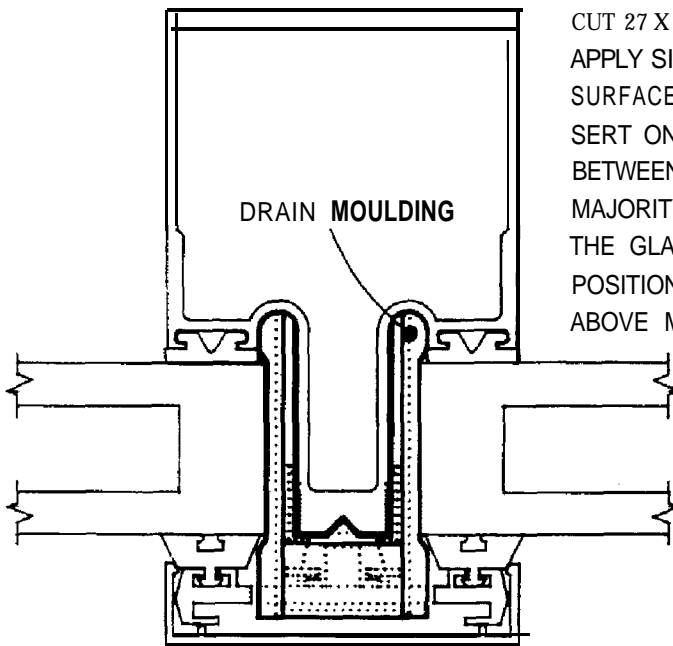

CUT 27 X 27 SQUARE HOLE IN CLAMP PLATE.
APPLY SILICON SEALANT TO ALL SURFACES OF THE DRAIN MOULDING AND INSERT ONTO THE NOSE OF THE MULLION BETWEEN THE GLASS/PANELS TO COLLECT THE MAJORITY OF ANY WATER RUNNING DOWN IN THE GLAZING RECESSES.
POSITION JUST BELOW THE DRAINAGE HOLES ABOVE MULLION JOINTING SLEEVE.

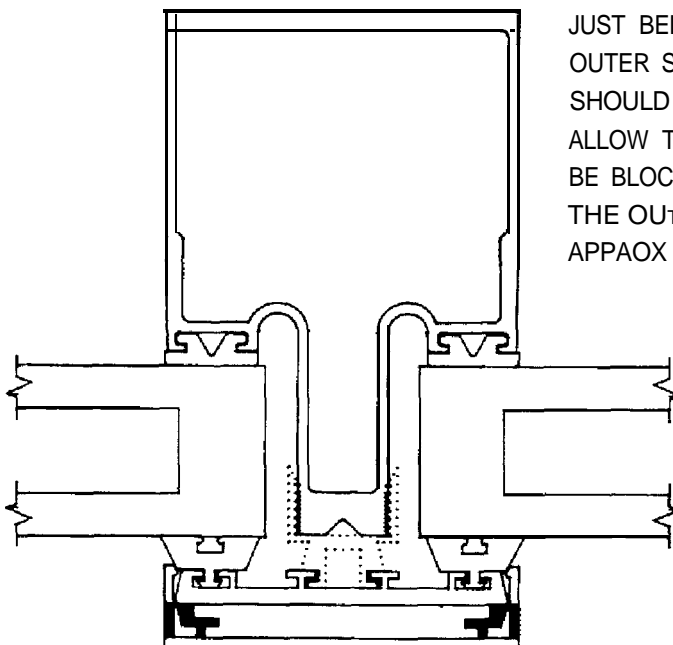

JUST BELOW THE DRAINAGE MOULDING THE OUTER SIDE WALLS OF THE CLAMP PLATE SHOULD BE REMOVED FOR ABOUT 50MM TO ALLOW THE CLAMP PLATE/CAPPING CAVITY TO BE BLOCKED OFF AND ANY WATER DRAINED TO THE OUTSIDE.
APPROX 10 X 4 SLOTS IN CAPPING SIDE WALLS.

Date 20th April 1990

General Bulletin

No. 143

312 CURTAIN WALL

ANGLED MULLIONS

By using existing 105/1 31 and 105/1 36 gaskets in conjunction with the 312/38 wide clamp plate and 17193 capping, it is at present possible to accommodate changes in the glass angle of up to 60° with a single mullion. To allow this angle to be increased up to a full 90° we are now introducing two additional gaskets, an outer solid EPDM gasket 105/1 54 and an inner sponge EPDM gasket 105/155 as illustrated below.

This facility can be especially useful for corner applications where vertical and sloping glazing join because it will allow a single mullion to be mitre jointed at the eaves and accommodate the variation in angle between the vertical and sloping glazing. These variations will mean that packing may need to be added to the spacer, or extra care taken not to overtighten the clamp plate, and a practical trial should be carried out for each condition variation.

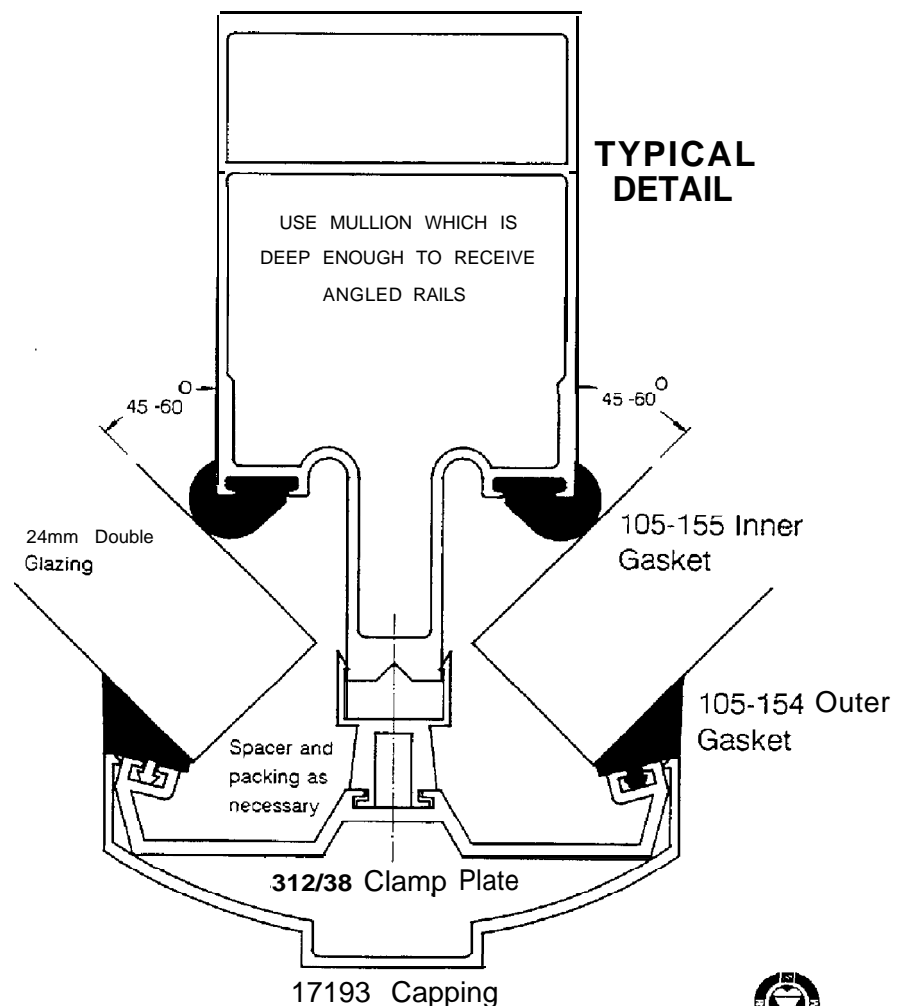

Date 12th November, 1990

General Bulletin

No. 146A

312 CURTAIN WALL

NEW GLAZING PACKER 312/81

As shown in the 312 Manual on page 50, a 5mm thick setting block must be positioned 50mm in from each end of every rail.

We are now introducing a special moulding for this purpose, as shown below, which must always be used. This item is used in exactly the same way as described on page 50, except that it is not necessary to notch back the top flange of the clamp plate spacer as this part is specifically shaped to fit over it. It is also recessed on the underside to allow any water to pass underneath and escape.

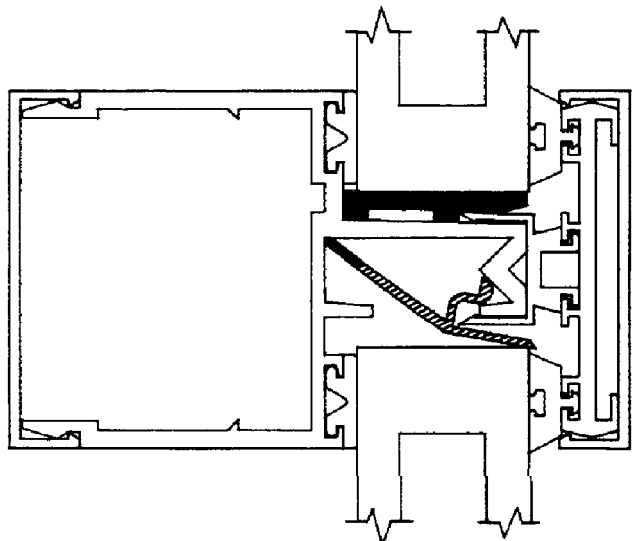
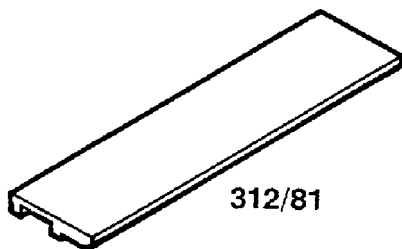

APPLICATION DETAIL

**Please Note that this Bulletin incorporates revised Application Detail.
It replaces previous Bulletin 146 dated 19th October, 1990**

Date 14th December, 1990

General Bulletin

No. 150

312 CURTAIN WALL

DISCONTINUATION OF 314 (65mm) CURTAIN WALL

Further to our **Dealer Support communication of 25th September 1990 concerning the above, the following parts are retained for use on the 312 Curtain Wall and have** been transferred into the 312 system as follows:

314/1 6 Serrated Mullion Bracket	now becomes	31216
314/1 52 Sub-cill fixing bole jig	now becomes	3121152

These new reference should be used for all future orders.

Date 25th March, 1991

General Bulletin

No. 155

312 CURTAIN WALL

17111 DRAINED RAIL

As a result of our policy of continuous product development, we are withdrawing profile 17111 Drained Rail, with immediate effect. Recent practical trials have shown that the system will drain effectively and still comply with BS 6375 Pan 1, Class 300 with the 17110 Normal Rail installed in place of the Drained Rail.

The withdrawal of this profile will remove the need for certain preparation details and will therefore simplify fabrication and installation, whilst in addition, the Normal Rail offers a material saving of approximately 12% over the Drained Rail in Mill finish.

The 312 Product Manual and Price List will be amended to reflect this change as soon as possible, the Curtain Walling Data Sheet having already been updated.

Further information may be obtained from Gtostal's Technical Department.

Date 29th May, 1991

General Bulletin

No. 162A

312 CURTAIN WALLING

GLASS SIZE

When using the double glazing edge protector 17155 it is recommended that after calculation of the glass size, the height be reduced by a further 1.0mm to ease application.

Note: This and all other curtain walling glass units should be held to a tolerance of + 1.0mm -2.0mm

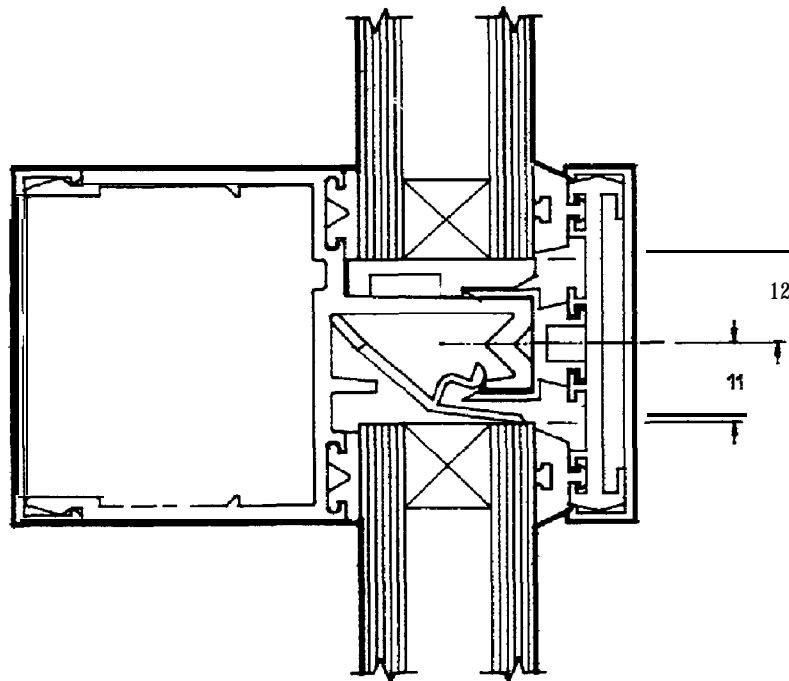

Dealer Information

August 1993

Technical Bulletin No 196

Additional Capping for 312/313 Curtain Walling

We are now introducing a new 60mm Mullion Capping 17235 to complement the existing range, details as shown, for use on both 312 and 313 Curtain Wall systems.

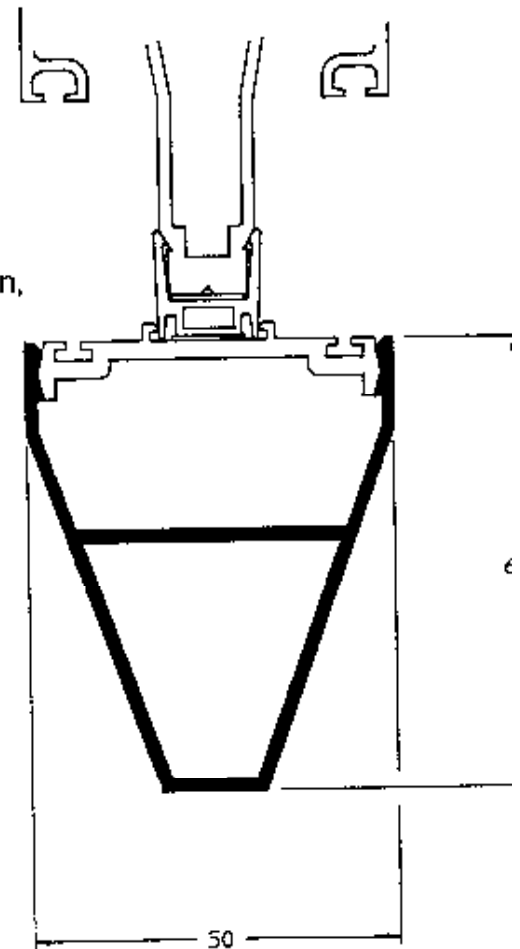

Gross Selling Prices

			per length	Per metre
17235	6100	ML	32.70	5.36
		SP	45.20	7.41
		ES	39.41	6.46
		B7	48.14	7.89

PLEASE ENSURE THIS INFORMATION IS CIRCULATED TO ALL DEPARTMENTS FOR ACTION AS APPROPRIATE

Date 28th January 1992

Technical Bulletin

No. 175

312 50mm CURTAIN WALL

THERMAL BARRIER SUB CILL

The existing sub cill profile 17120 has a very small exposed outer surface which means that it allows very little heat loss, but this would increase where it is linked with cill pressings.

To cover for this condition and any others where possible heat loss may be critical, we have introduced two new profiles which, when linked by gasket **105/142** form a thermal barrier assembly. It is applied in exactly the same way as the existing sub cill, using the 312113 cill retainers and 312/2 joint covers.

The only variation which must be allowed for is the 8mm height increase which was necessary to accommodate the thermal barrier detail. All as indicated on the full size profile detail below.

Note that the 17723 nose profile will receive 14g pressed cills or linings and, where appropriate, the pressing can fit directly into the gasket completely replacing the extruded nosing.

1
 105/1 42 Connecting Gasket

2
 Recess sealed with silicone
 when assembled

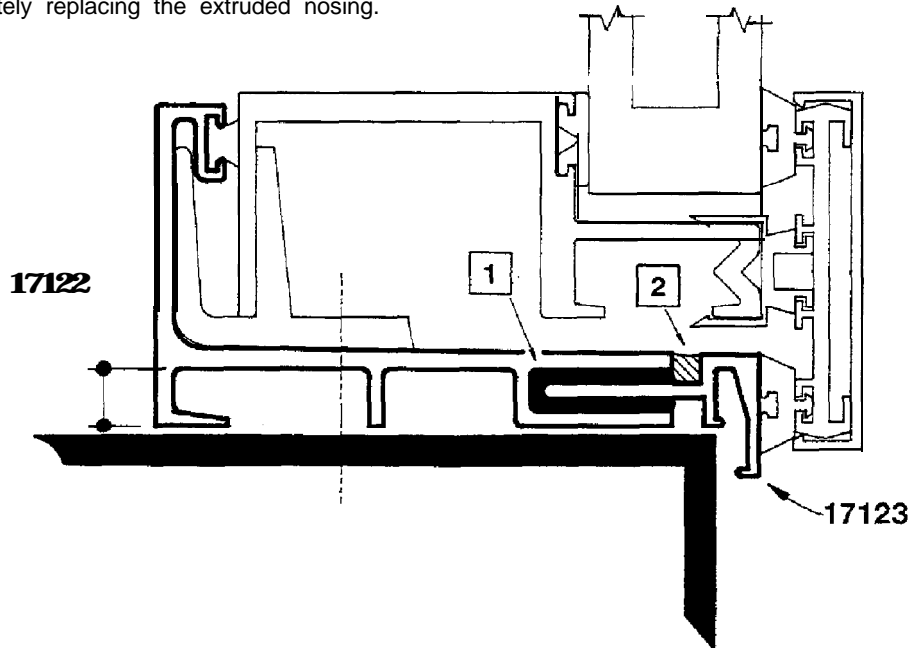

Manual	•	Price List	•	Tooling	•	Estimating Data	•	CAD	•	Data	•
--------	---	------------	---	---------	---	-----------------	---	-----	---	------	---

PLEASE ENSURE THIS INFORMATION IS CIRCULATED TO ALL DEPARTMENTS FOR ACTION AS APPROPRIATE.

Date 28th January 1992

Technical Bulletin

No. 176

312 50mm CURTAIN WALL

ADDITIONAL MULLION PROFILE 17108

The number of mullions in this range is being extended by the introduction of an additional 160mm box mullion, as illustrated.

The lower (front) box shaping relates exactly to all other existing mullions, the only variation being the upper (back) extension.

The wind loading inertia value for the new mullion in combination with the basic 312/1 8 clamp plate is 3,838,000mm⁴.

This inertia value can obviously be increased by the addition of reinforcements into the back tube as appropriate.

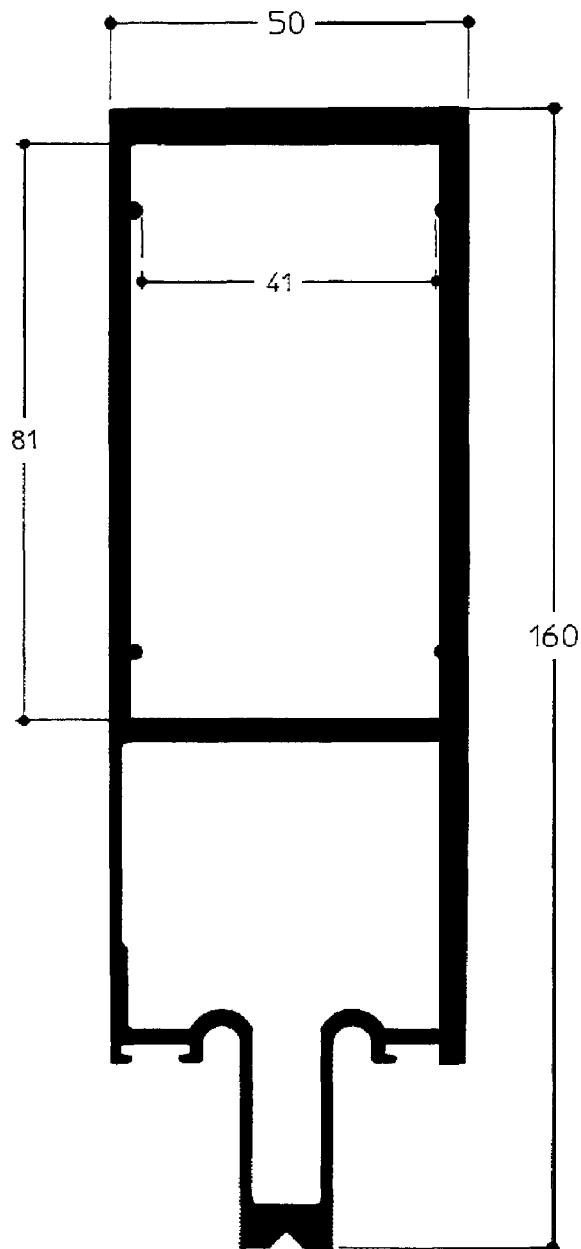

Manual •	Price List •	Tooling	Estimating Data •	CA D Data •
----------	--------------	---------	-------------------	-------------

PLEASE ENSURE THIS INFORMATION IS CIRCULATED TO ALL DEPARTMENTS FOR ACTION AS APPROPRIATE.

Technical Bulletin

No. 177

Date 28th January 1992
 amended December 1993

312 50mm CURTAIN WALL

SELF SUPPORTING EAVES RAIL

To deal with conditions where roof mullions come in the centre of a vertical frame and where the vertical mullions are too widely spaced to use the normal 17195 eaves trim, we are introducing two new profiles 17295 and 17333, as illustrated.

The upper portion of this new rail is similar to the 17195 eaves trim and will receive the 17194 roof rail, but it has been designed to fit between the vertical mullions instead of running continuously across the top.

The lower portion is arranged to repeat the standard rail, so that the standard glazing and clamp plate condition can apply, and an upstand nib to receive eaves inings.

Its depth has been arranged to give effective 'sag' support and also accommodate added reinforcement to increase its strength still further where necessary. Either aluminium profile 975 or a 90 x 50mm rectangular steel hollow can be accommodated.

The capping profile 17333 is arranged to clip onto the inside legs when fitting is complete.

The 'sag' inertia value of profile 17195 is

The 'wind load' inertia value is

See overleaf for typical application details.

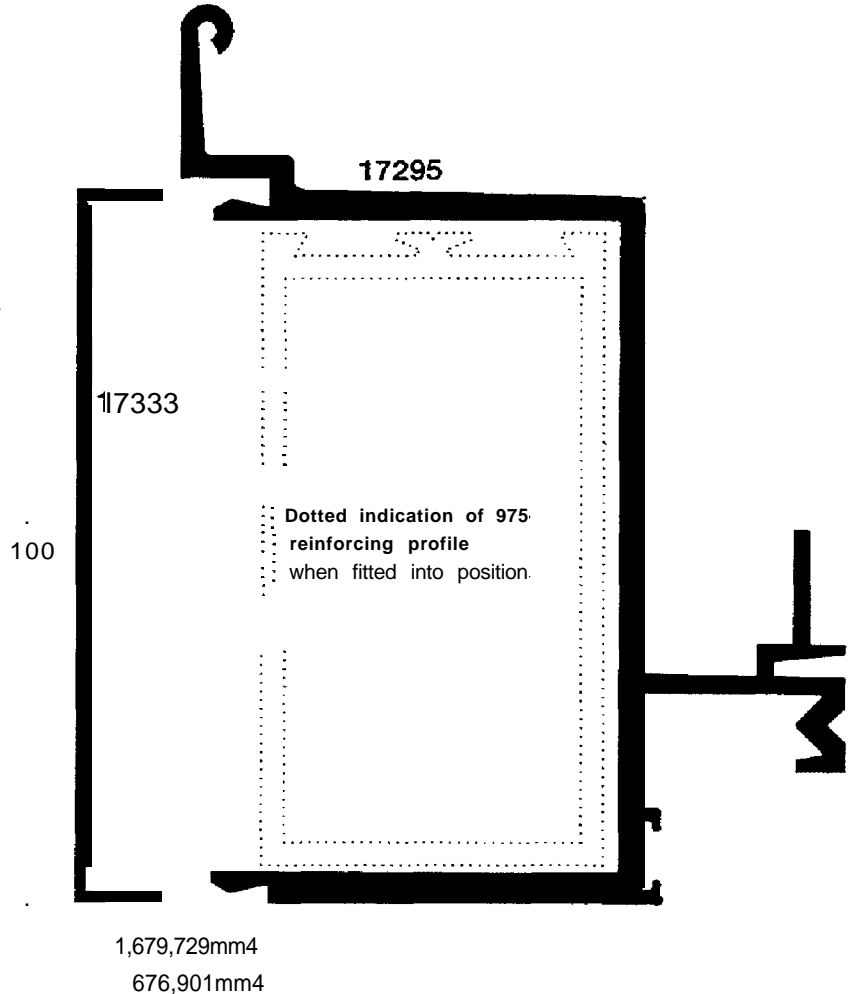

TYPICAL APPLICATION OF DEEP EAVES RAIL ASSEMBLY

This detail illustrates the mullion attachment at sides. Any intermediate sloping mullion which terminates at the rail must be shaped at end to dress over the inner upstand of the rail and be securely bracket fixed to it.

- 1** Very important that the perimeter of the rail joint with mullions is completely sealed with a bead of silicone in hatched areas to prevent any water penetration.
- 2** Eaves lining formed from pressed aluminium and angle as appropriate to suit the sloping angle and thickness of glazing.
- 3** Eaves lining joined to, and insulated from, the rail upstand by 3mm thick double sided adhesive sponge tape.

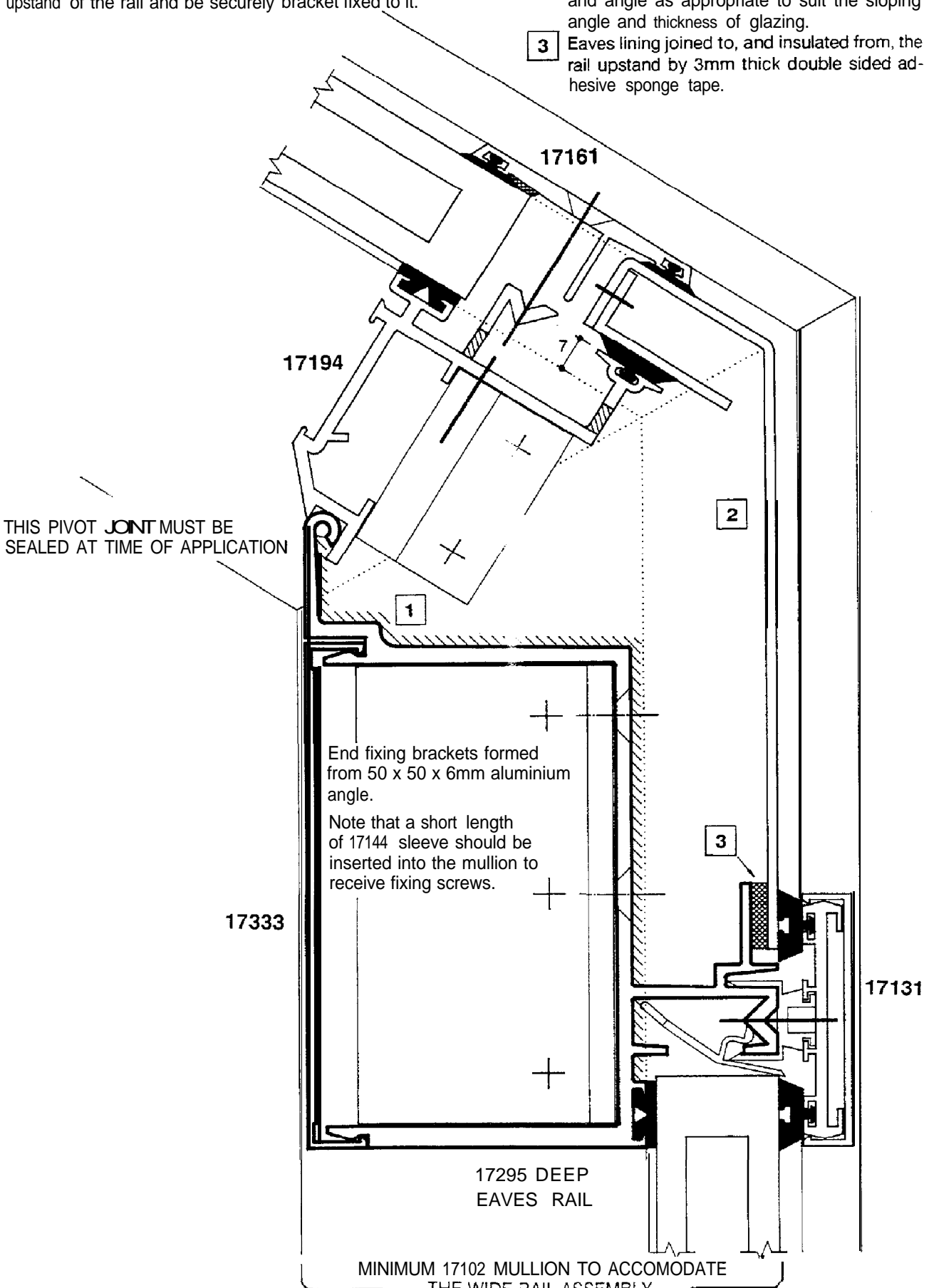

Technical Bulletin No 196

Additional Capping for 312/313 Curtain Walling

We are now introducing a new 60mm Mullion Capping 17235 to complement the existing range, details as shown, for use on both 312 and 313 Curtain Wall systems

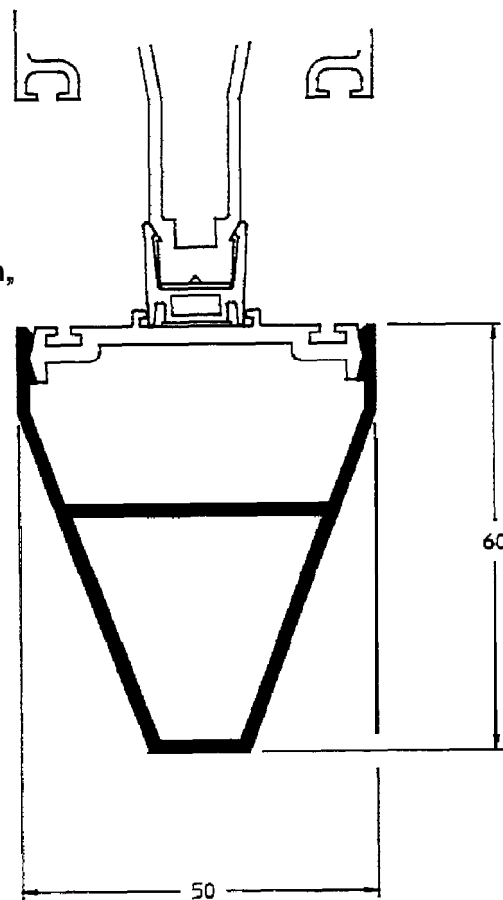

PLEASE ENSURE THIS INFORMATION IS CIRCULATED TO ALL DEPARTMENTS FOR ACTION AS APPROPRIATE

Specification

Scope

- 1.1 This specification defines the basic design concept, construction, materials, fittings and performance of the Glostal 312 (50mm) Curtain Wall and sloping glazing.

Design concept

- 1.2 The profiles and components in this range have been specially designed by Glostal to provide a simple form of thermally insulated construction which will have a universal application.
- 1.3 Built-in features, such as complete pressure equalisation of glazing cavities and the accommodation of all vertical and horizontal thermal movement without any stress on seals or joints, overcome the problems which plague many other forms of curtain wall.
- 1.4 In addition to vertical glazing this construction can also be extended into sloping (roof) glazing using the same mullion members.

Materials

- 1.5 Aluminium alloy 6063 TE & TF, stainless steel and appropriate high quality seals used throughout.

Finishes

- 1.6 The construction allows for fabrication of all exposed members from pre-finished lengths of aluminium extrusion.
- 1.7 These exposed profiles will be available in a range of finishes:
 - a) Anodised to BS 3987, Grade AA25. Etched and anodised natural self-colour.
 - b) Anodised to BS 3987, Grade AA25. Etched and anodised Glostal Bronze.
 - c) Anodised to BS 3987, Grade AA25. Etched and anodised Glostal Black.
 - d) Stoved organic finish in RAL colours to BS6496

Construction

- 1.8 Many years of practical experience have been built into the form of 'stick' construction adopted, which consists of main mullion members with intermediate transom rails fitted to prepared brackets to form the basic framing grid. The infill of glass, panels or opening lights is then applied and the installation completed by the fitting of the outer clamp plates and cappings.

Glazing /Infill

- 1.9 The range has been designed for a basic 24mm glass or panel thickness, but it is also arranged so that any thickness between 5 mm and 32 mm can be accommodated by varying the glazing condition.
- 1.10 A range of opening lights and doors can be directly accommodated in the vertical glazing, and a roof ventilator is also available.

Performance (thermal)

- 1.11 In its double glazed condition the inside structural members are separated and insulated from the outside cappings which results in an effectual thermal barrier giving a thermal transmittance value for the aluminium framing of approximately 3.0 watts per square meter per degree centigrade. This closely matches the double glazing and reduces heat loss and condensation.

Performance (weather)

- 1.12 The unique construction allows for a very effective inside seal which is free from any stress caused by thermal movement. This, combined with automatic pressure equalisation and drainage, means that any correctly installed Curtain Wall framing will be completely watertight under the maximum 'class 300' pressure specified in BS 6375: Part 1: 1983.
- 1.13 This form of construction also means that the Curtain Wall framing can meet the maximum 'class 600' (air conditioning) pressure specified in BS 6375: Part 1: 1983 for air leakage.
- 1.14 For wind resistance, the Curtain Wall framing will meet any specified requirement subject to the adjustment of spans and fixings.

Performance (inserts)

- 1.15 As will be appreciated, the thermal and weather performance of any insert will depend on the unit concerned and the appropriate technical details should be consulted.

Sapa's policy is one of continual system development and we reserve the right to incorporate design improvements and changes. Every effort is made to ensure that all details are correct at time of publication. However, it is the responsibility of the customer to check the accuracy of the relevant facts and information before entering into any contract or other commitment. Up to date information is freely available from the Sapa Building Systems Webshop.

All Products and systems which Sapa supply are supplied subject to Sapa's standard Terms and Conditions of Sale current from time to time.

General arrangement - vertical glazing

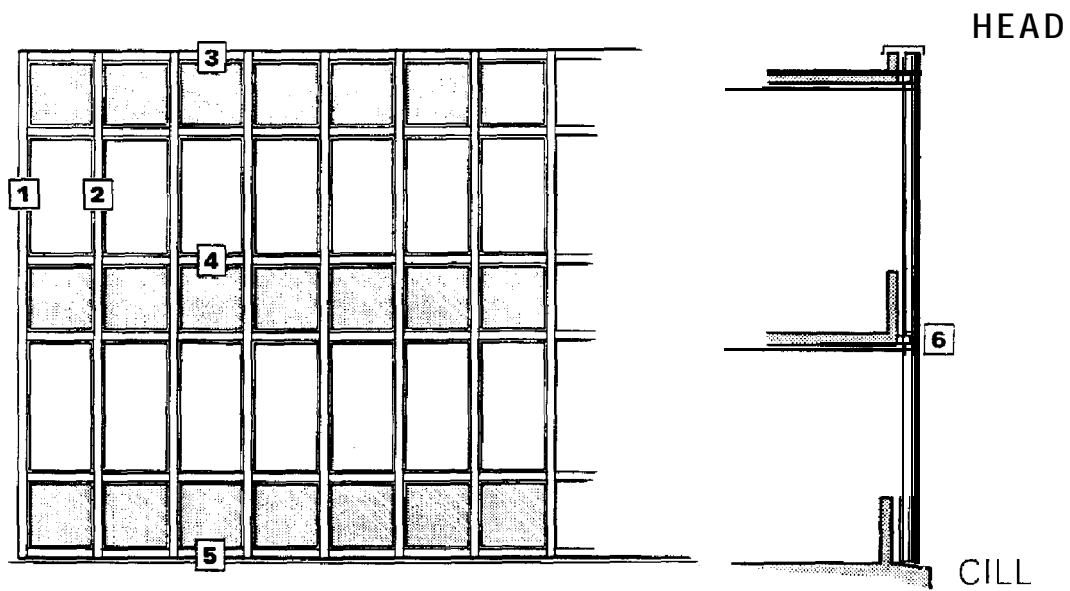

INSIDE

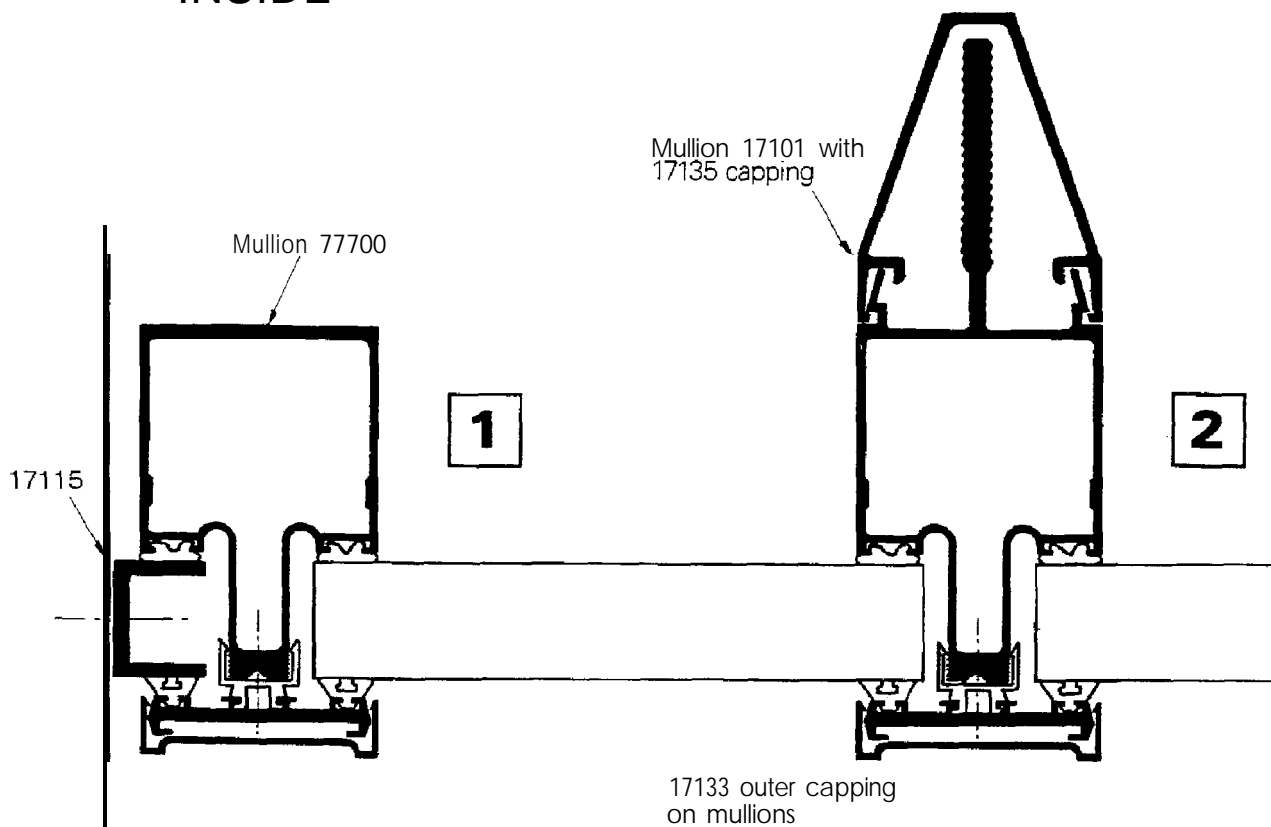

OUTSIDE

3

HEAD

1710 5 channel lining

Normal rails 17110
with 17131 inner capping

312118 clamp plates
with 17131 capping

4

Bottom rail 17112

5

Sub-cill 17120

CILL

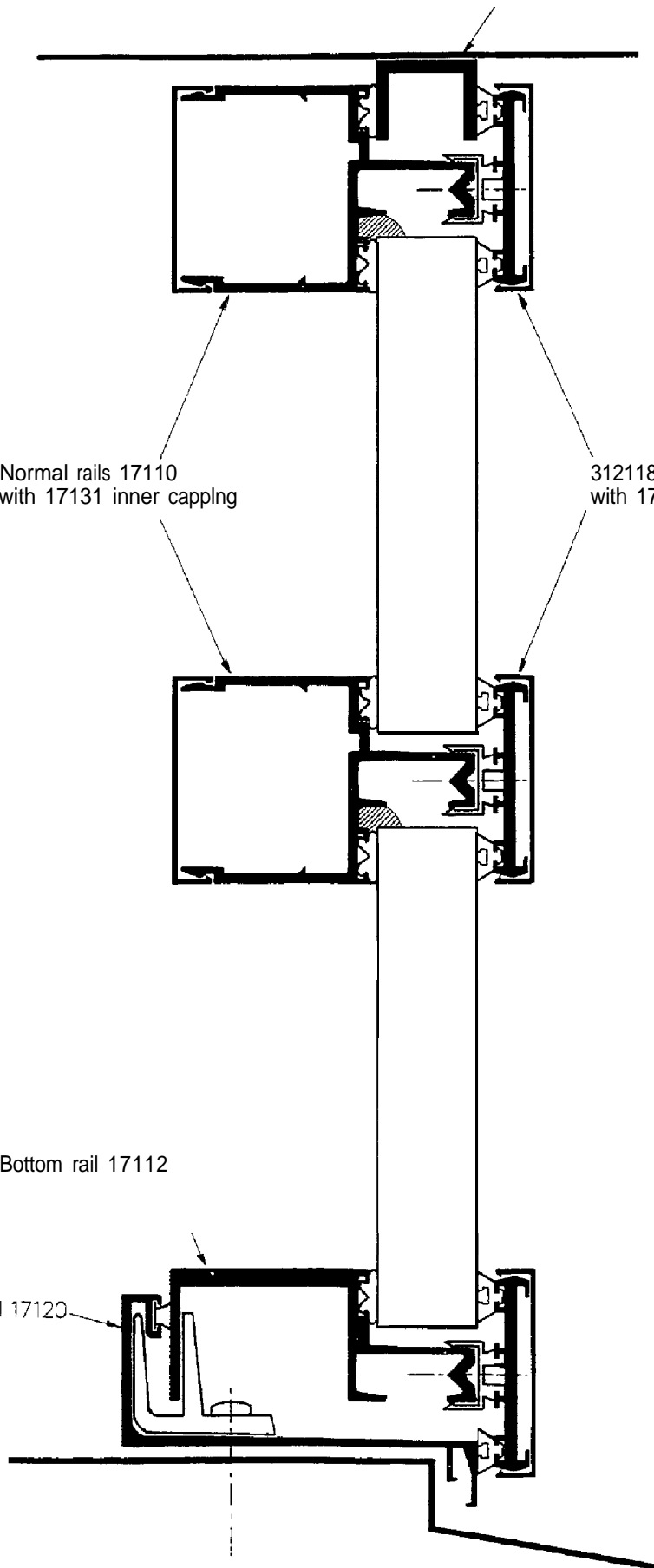

Typical general Arrangement: sloping

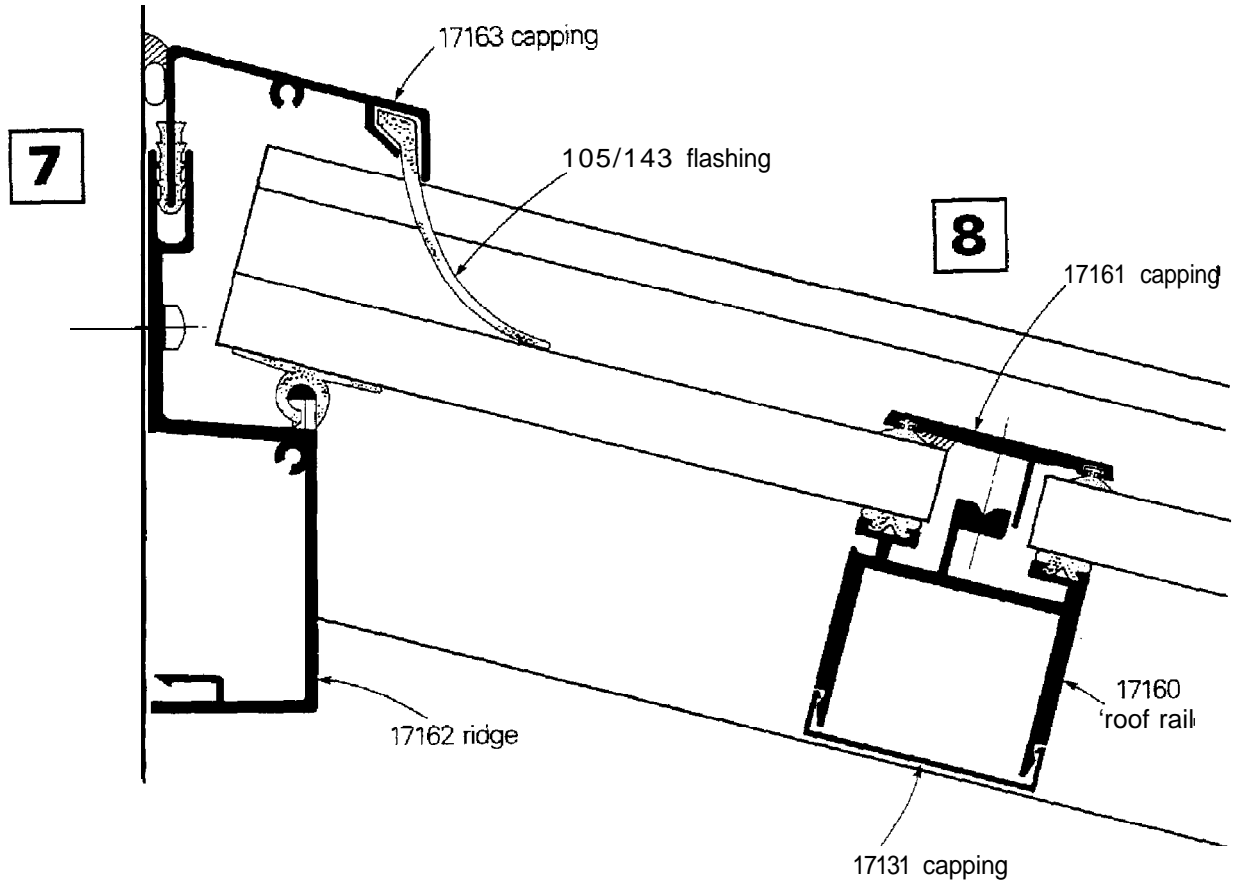

10

Pressed aluminium corner lining and modified 312116 spacer blocks to suit the condition

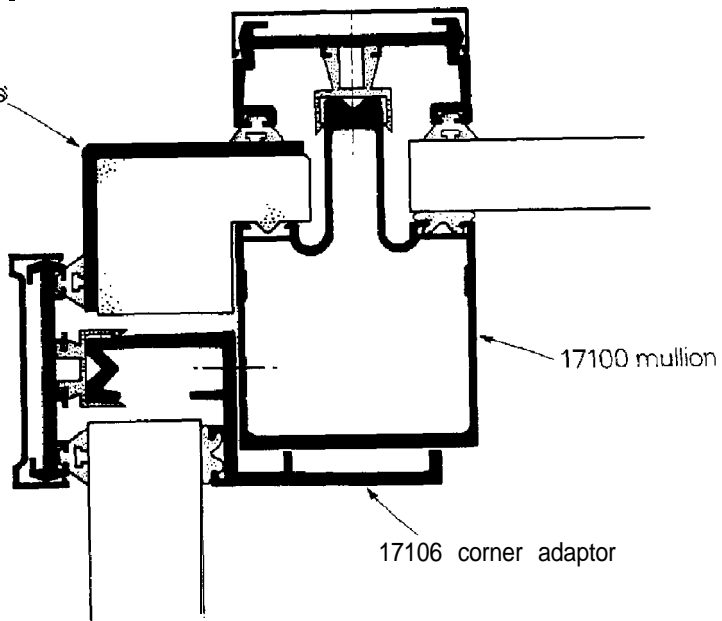

Glazing

Details based on 15" slope with 24mm vertical glazing, 16mm polycarbonate roof glazing and gutter

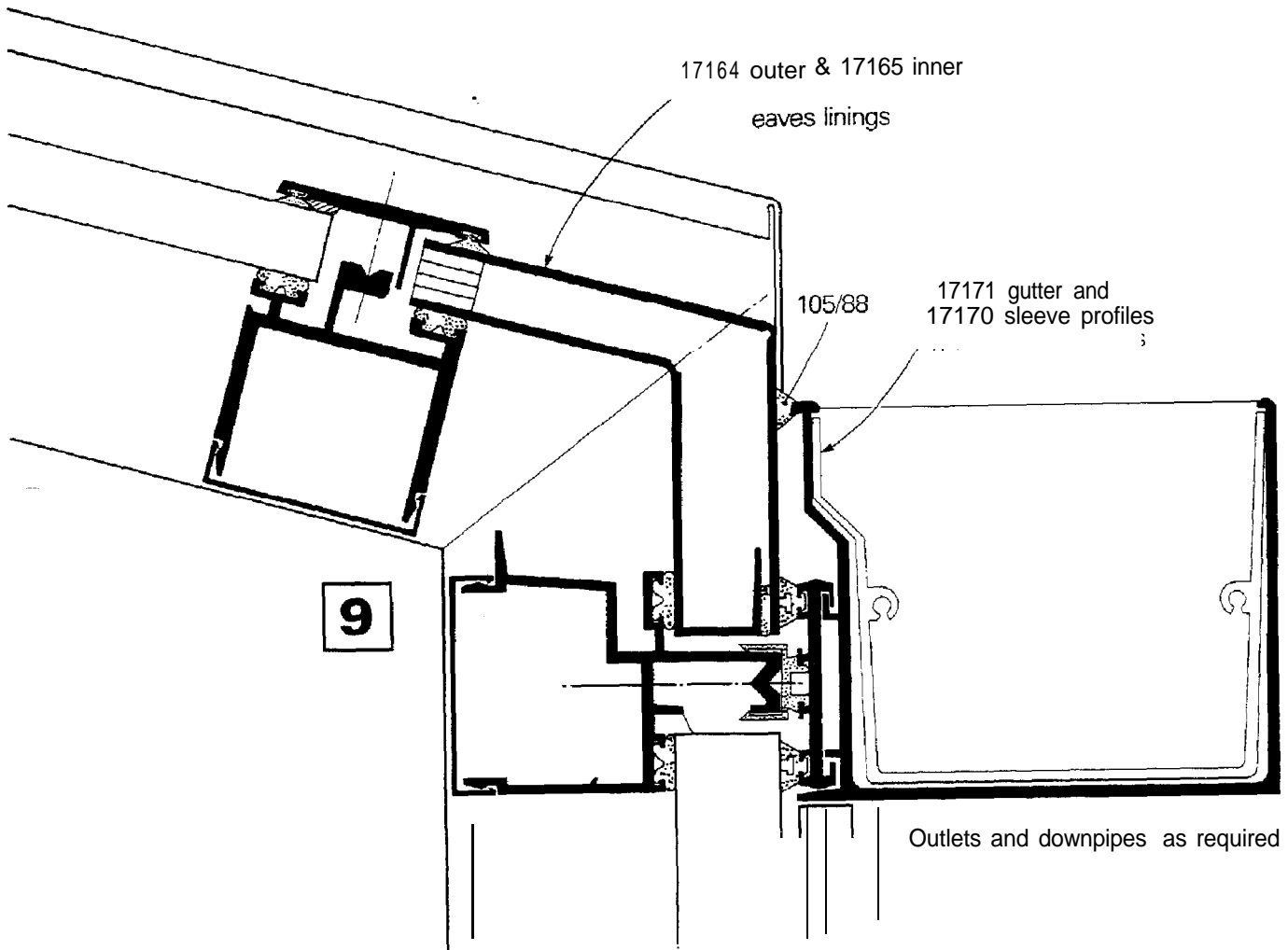
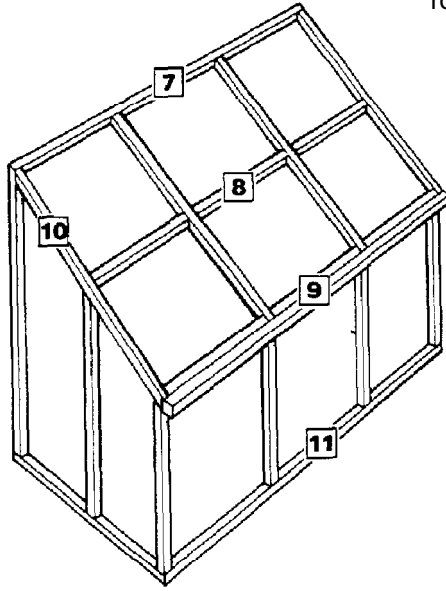

Mullion jointing and fixing – ‘hung’ condition

314/16
mullion
bracket

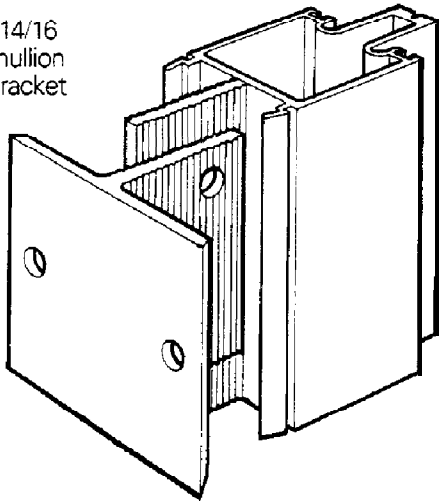

13mm dia outlet holes
through the sides of
mullion nose just in
front of shoulders.

Two 312/17 mullion
plugs with silicone to
'completely seal the
mullion tube

155

200mm length of mullion
sleeve 17144 secured to
the mullion above and a
sliding fit into the mullion
below

Nominal 5 mm expansion
gap between mul-
lions

Sleeved joint

Solid fixing

Note that clamp plates should
be the same length as mul-
lions but cappings should be
butt jointed about 100mm
below the mullion joint

Anchor bolt

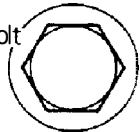

Anchor bolt

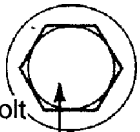

Mullion bracket 31. 16
- securely bolted to the top
of the mullion and fixed
back to the structure

- Line and level bolt

Typical fixing
channel cast
into the floor
slab

M10 x 40 hex
set screw

85 ± 15mm

Note: Mullion shown
prior to glazing

6

'prop' condition

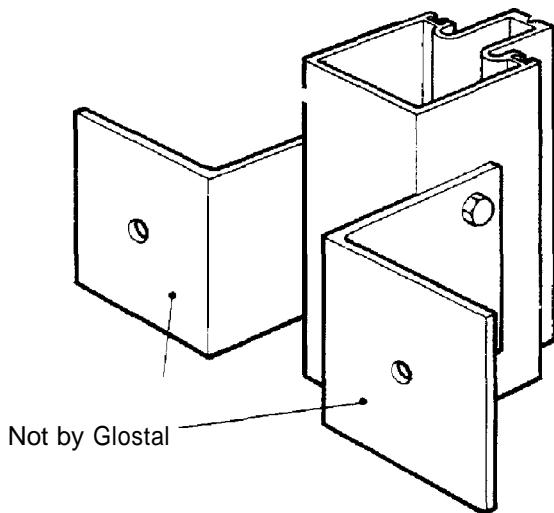
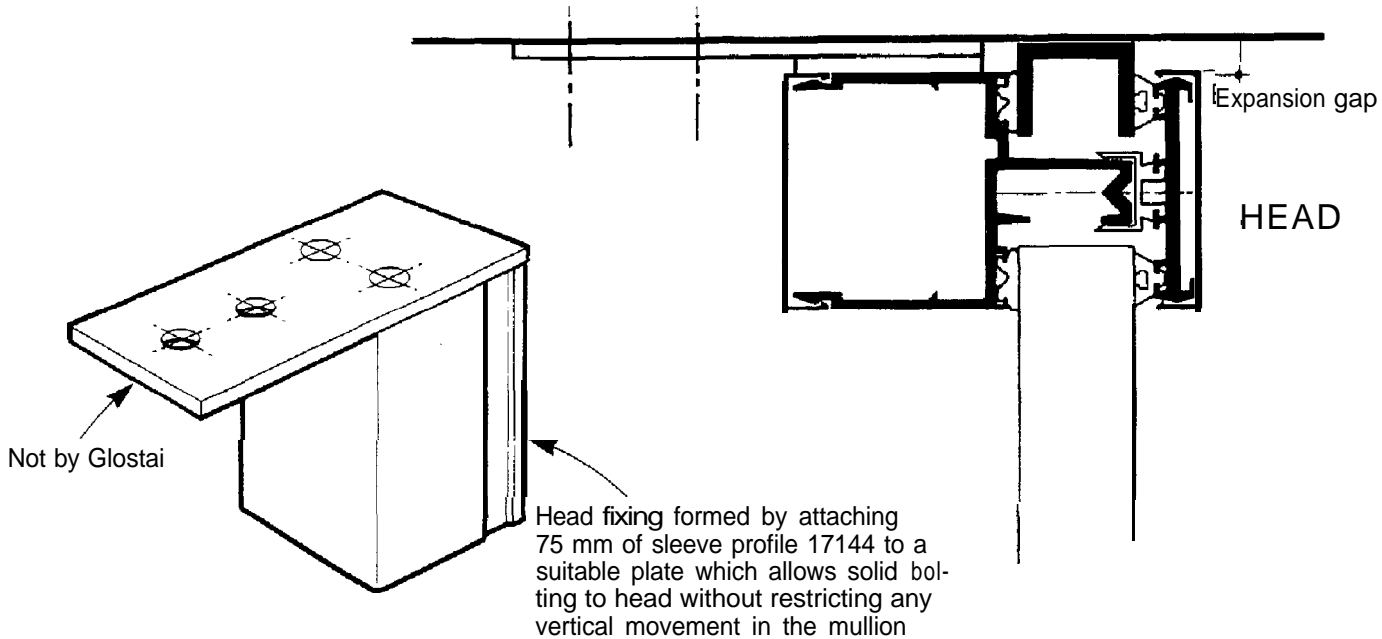

Typical fixing bracket arrangement for securing box mullions 17100,2 & 3 using angles secured at the sides of the mullion and bolted to the building structure. Solid fixings for 'hung' construction but slotted to allow for thermal movement when used as fixing ties in 'prop' construction.

Note: Bolts securing the angles to the mullion should be long enough to run through the whole assembly.

The 'prop' condition is appropriate where the total height allows for single length mullions and where the head and any intermediate structure is not strong enough to carry the dead weight of the curtain wall.

In these cases the mullions and bottom rails are taken further into the sub-cill to sit directly onto the cill retainers so that the total dead weight is taken at these fixing points as illustrated.

All fixings above are then only required to give support against wind loading and allow for thermal movement

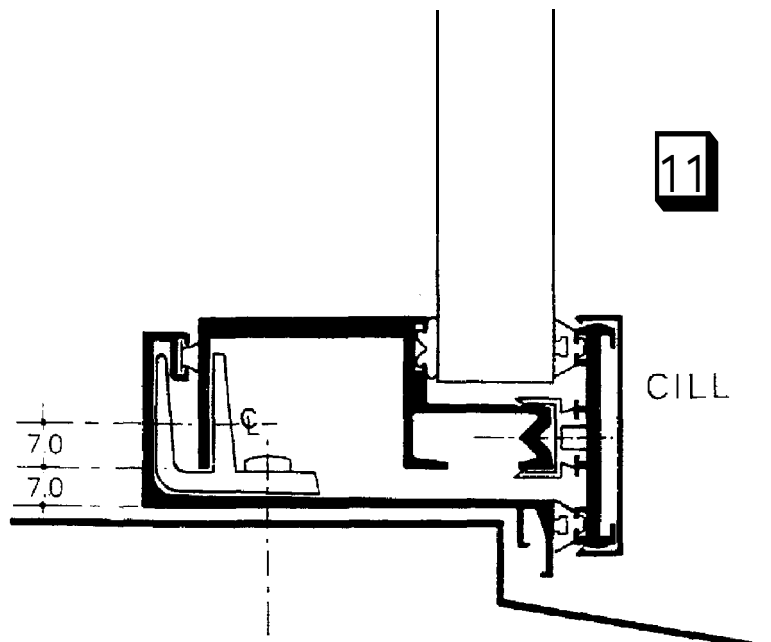

Mullion assemblies - basic

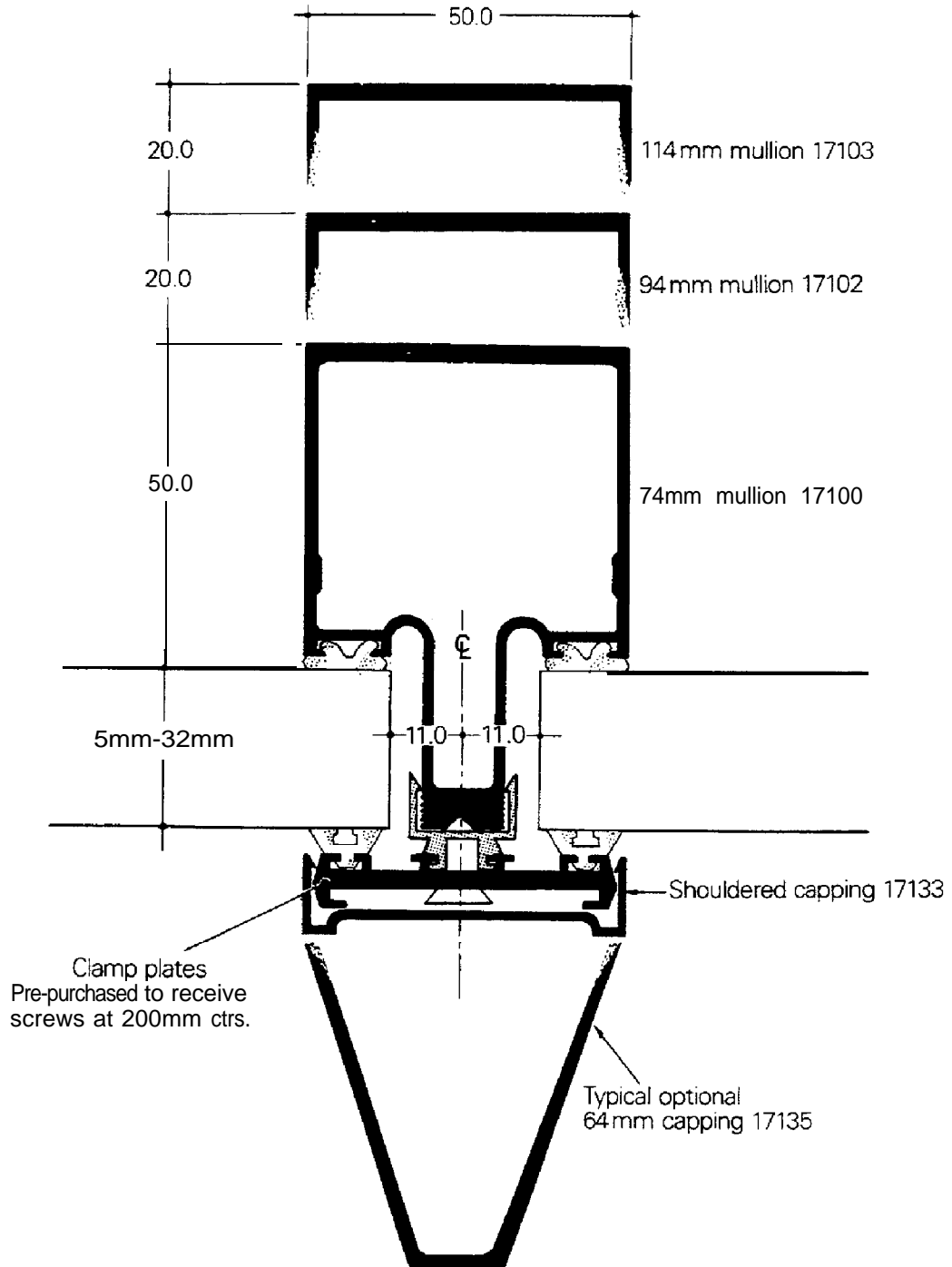

Mullion assemblies - reinforced

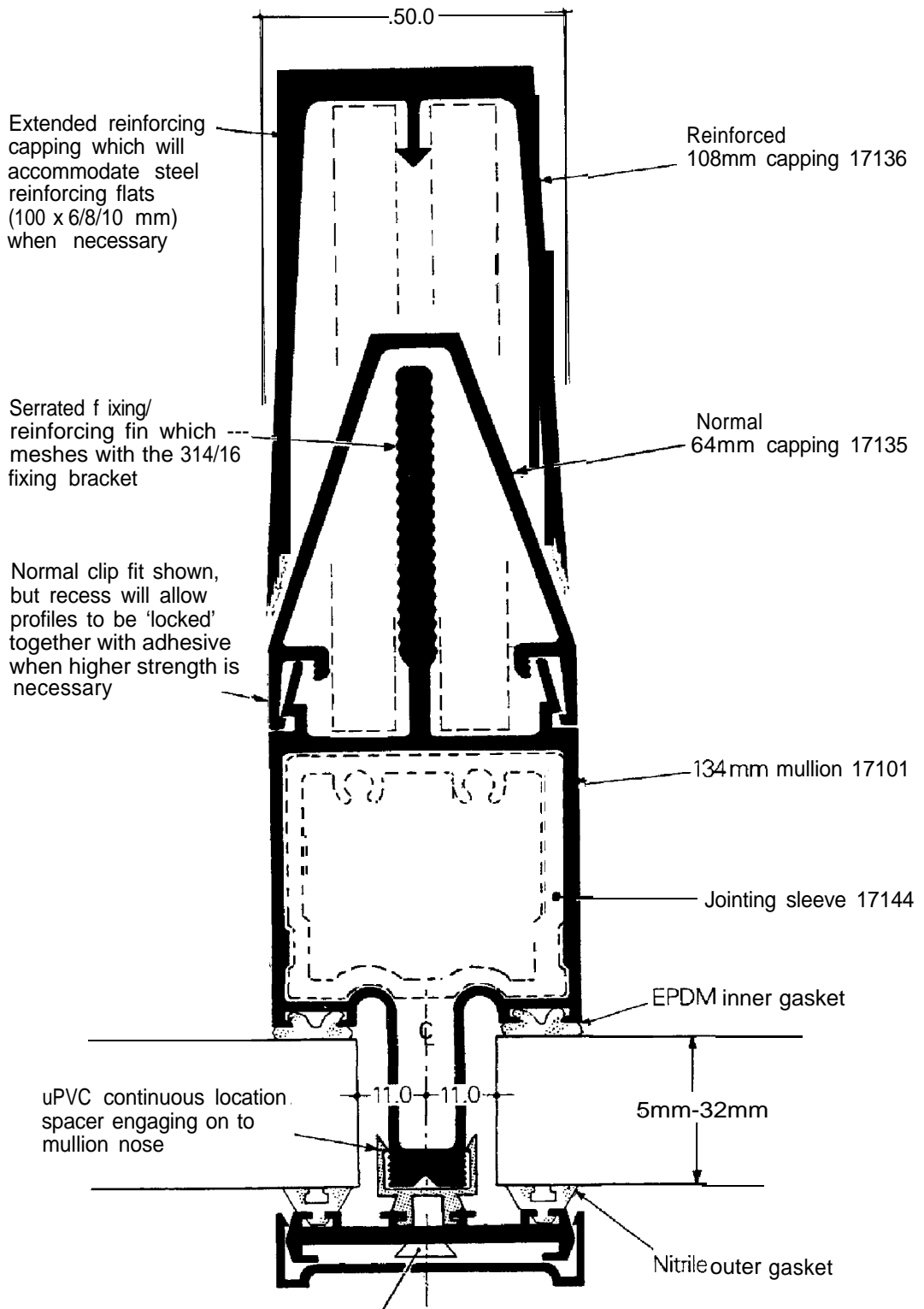

All clamp plates secured by No. 12 x 1" csk stainless steel self-tapping screws passing through prepared holes in clamp plate into 4.8mm dia drilled holes in mullion/rail.

OUTSIDE

Corner details

Based on 24mm glazing

The basic 17100 mullion can almost always be used in these conditions because both the change of direction and additional members give much greater strength

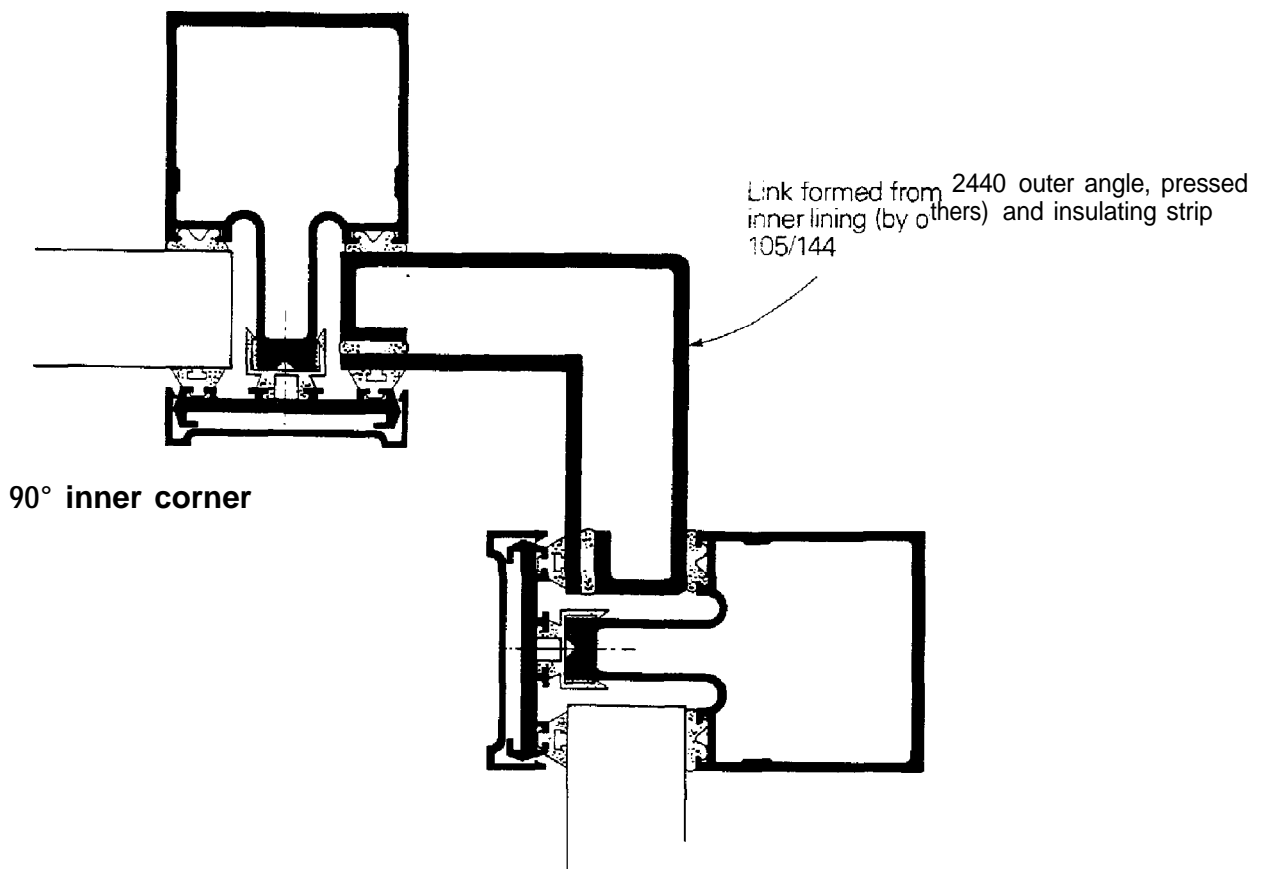
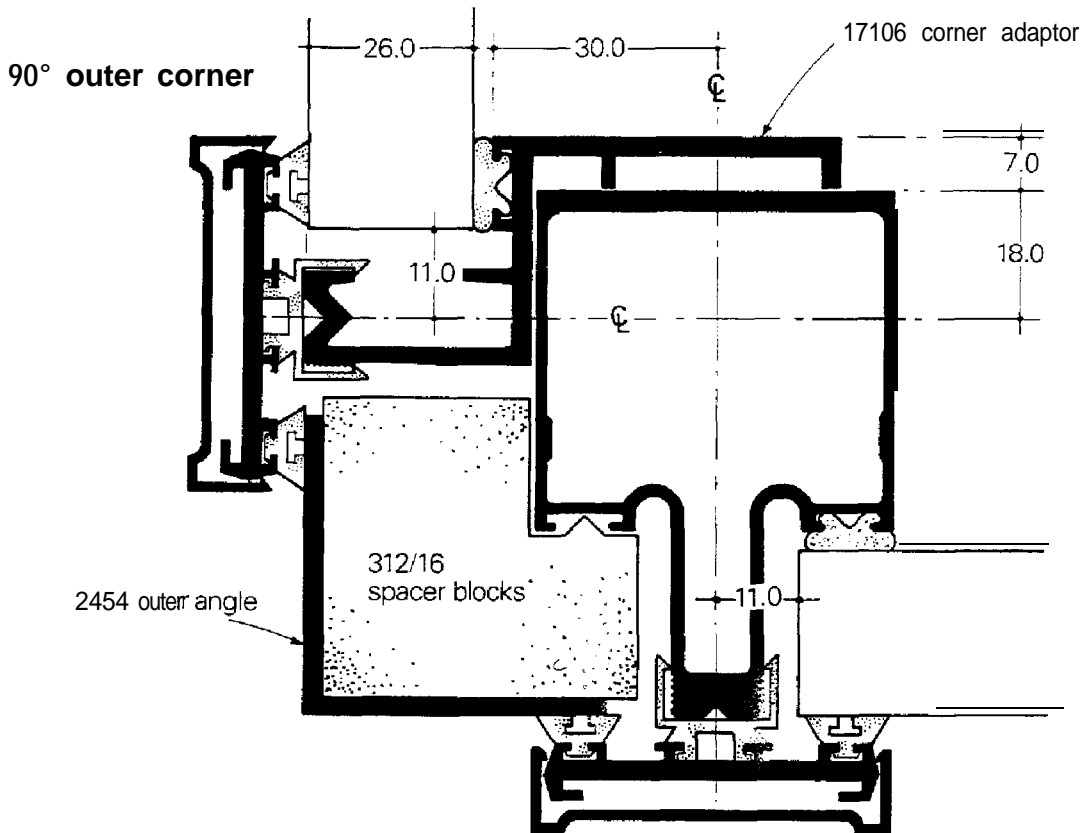

Rail assemblies

Normal rail 171 10

Rails fit over mullion brackets and are then closed off with 17131 capping

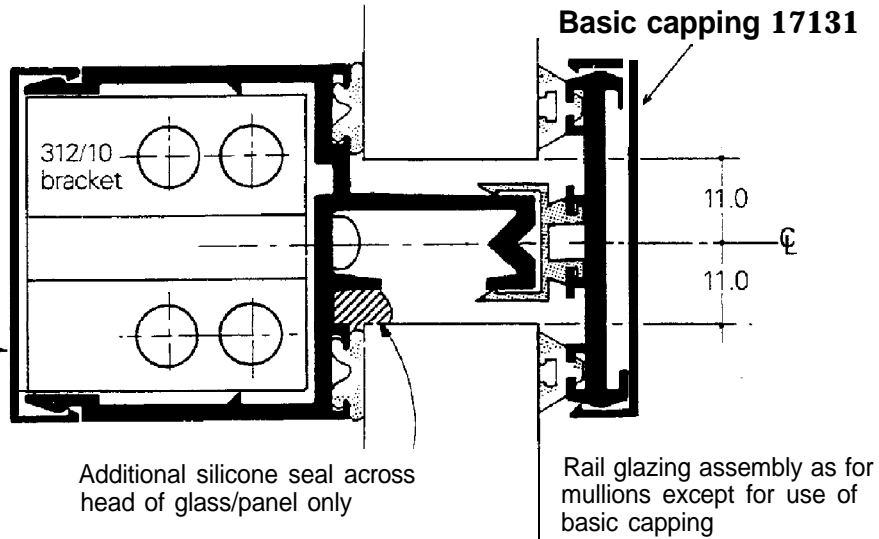

Drained rail 77111

This rail is fitted below all mullion joints, opening lights, eaves, or wherever an inside drainage facility is appropriate

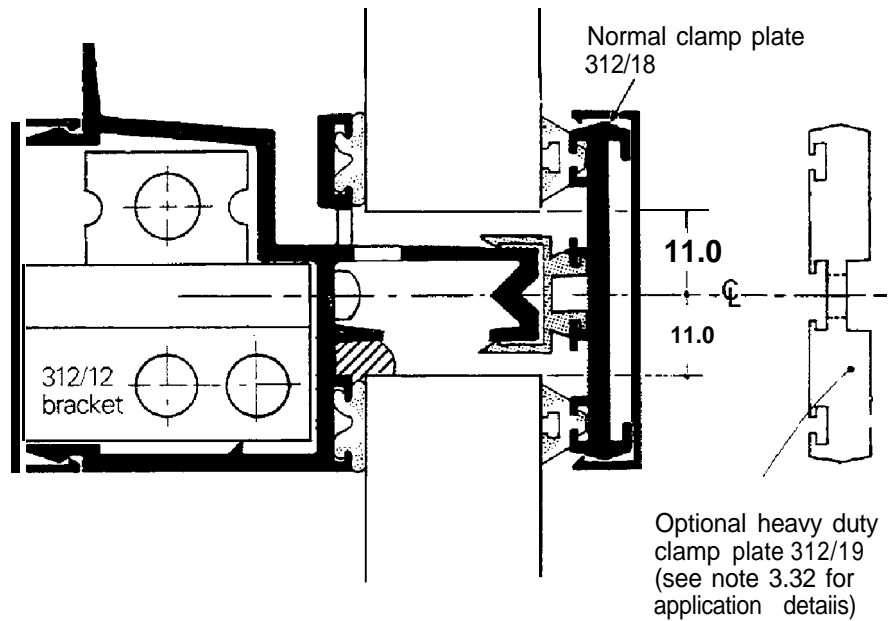

Bottom rail 17112

Sub-till 17120

'Hung' condition - 11.0 (7mm 'prop')

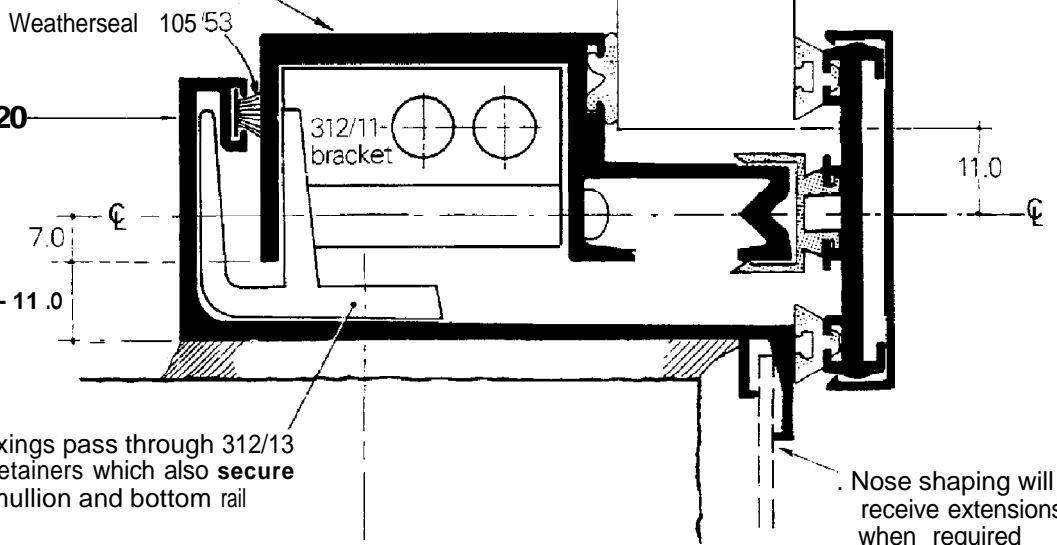

Opening light assemblies

Typical condition (316)
 illustrating the use of special
 frame profiles available for 311
 & 316 ranges
 [311: profile 12113 (T)
 316: profile 16004 (T)

Typical detail illustrating the
 use of profile 17115 fitted to
 box frame units to allow
 direct glazing

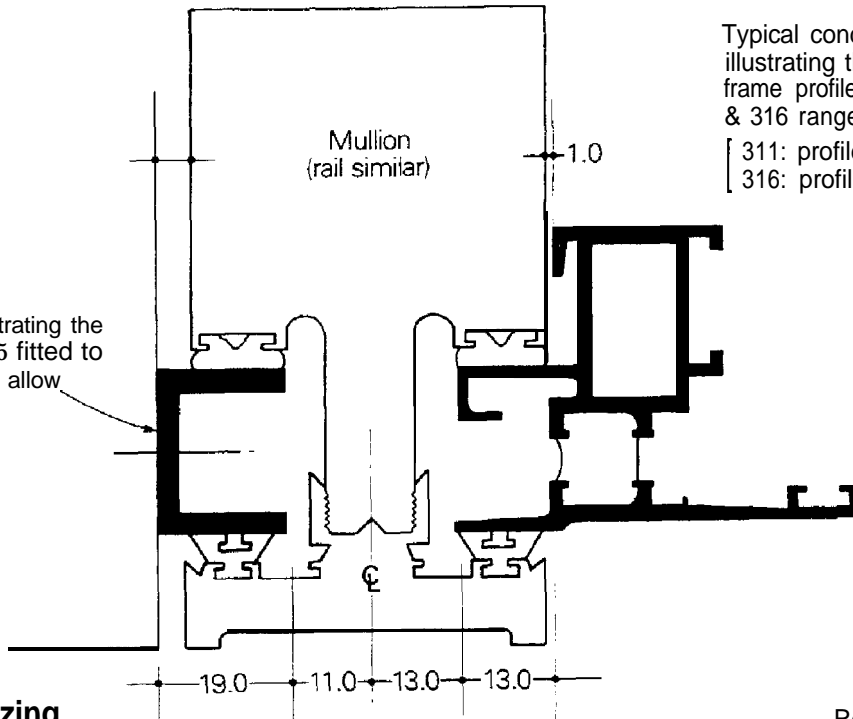

Roof vent glazing sealed by
 channel gaskets

17180/T opening vent mitred at corners
 and secured by 31/28 cleats and No 12
 x 2" pan hd S.S. self-tap screws

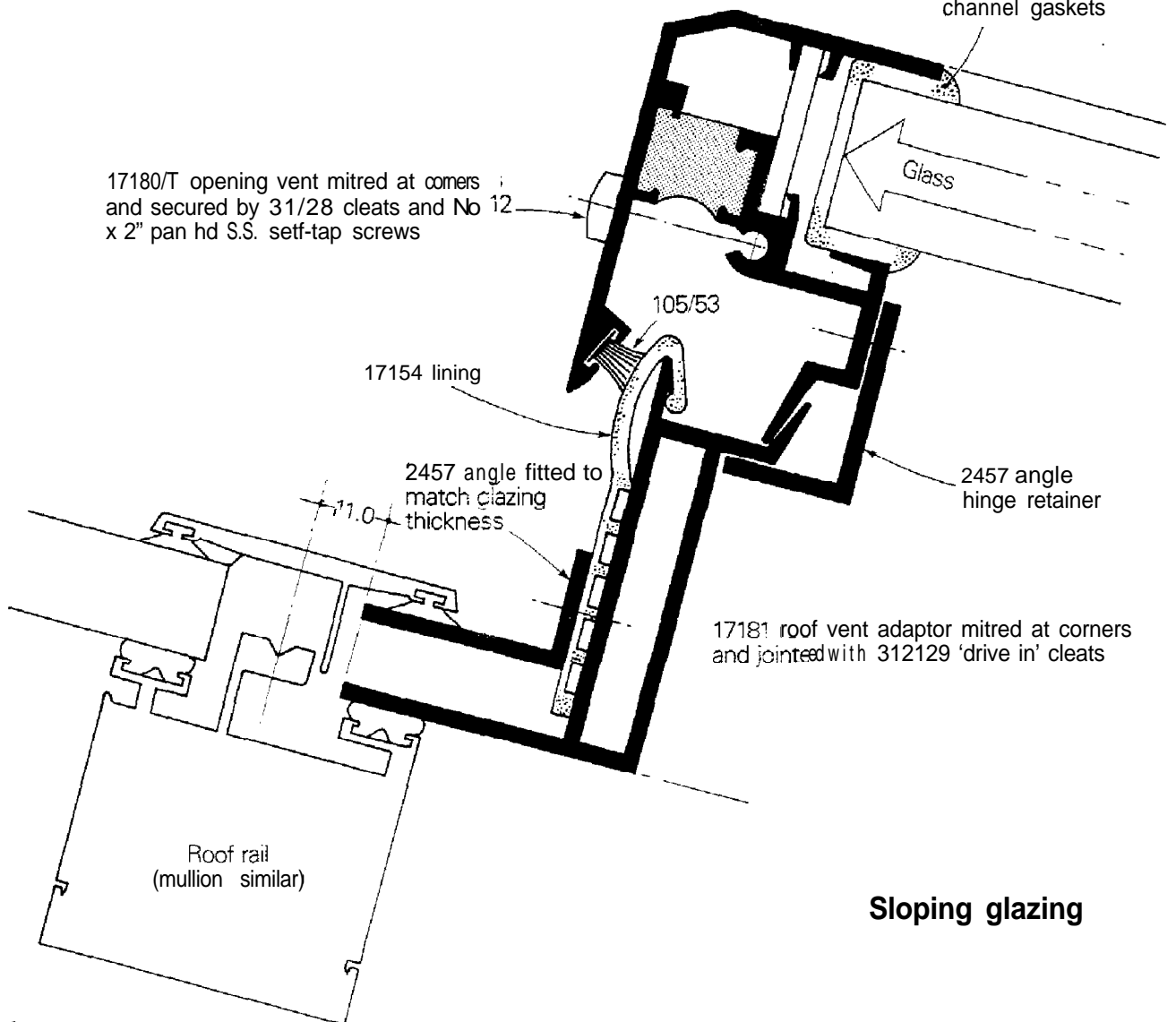

Ridge & roof rail assemblies

88

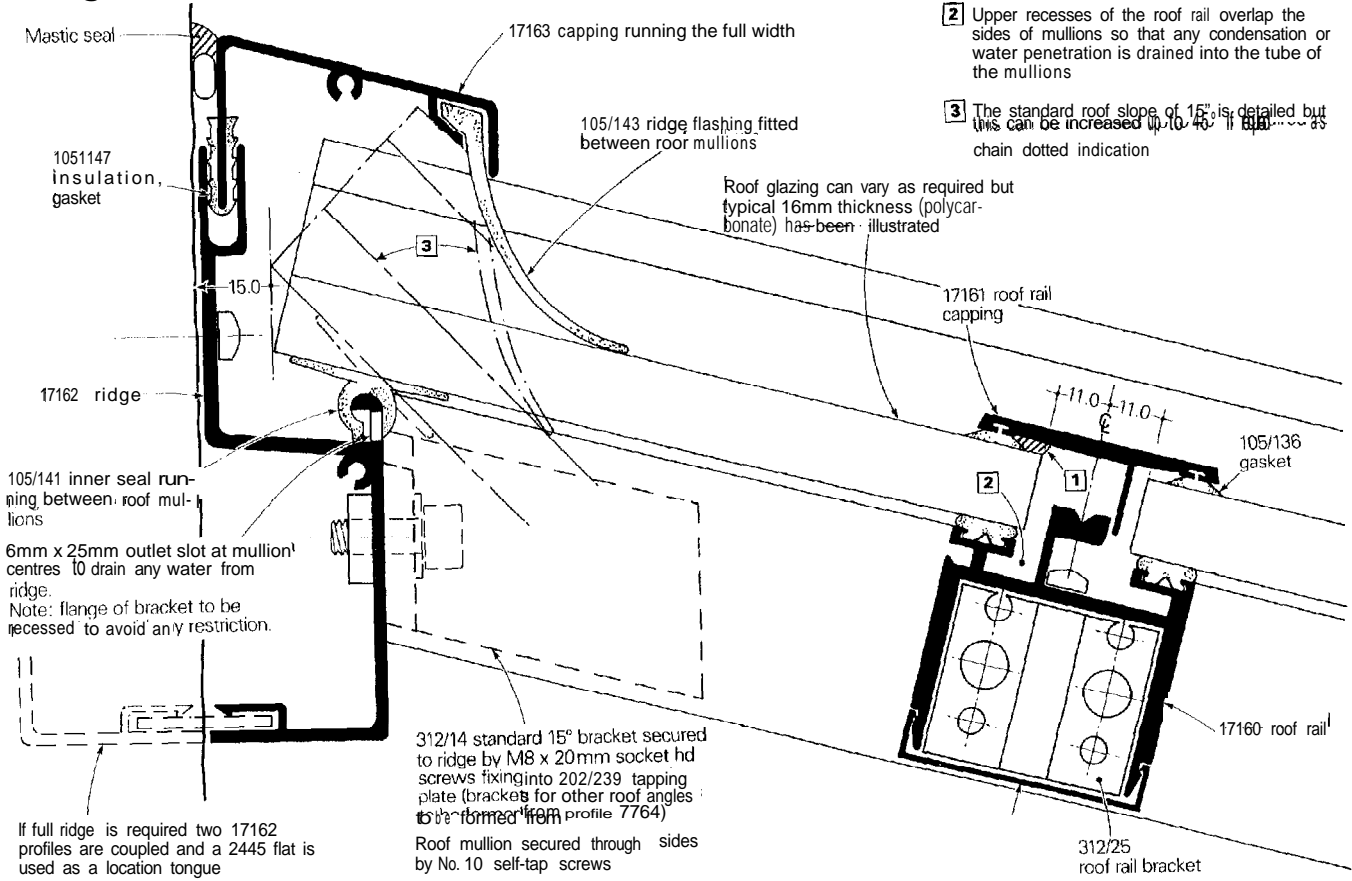

- 1** Silicone backing seal to form extra barrier to water penetration.
- 2** Upper recesses of the roof rail overlap the sides of mullions so that any condensation or water penetration is drained into the tube of the mullions
- 3** The standard roof slope of 15° is detailed but this can be increased up to 40° if required as chain dotted indication

Eaves assembly (without gutter)

Shown with typical differing glazing thicknesses, 16mm in slope, 24mm in vertical

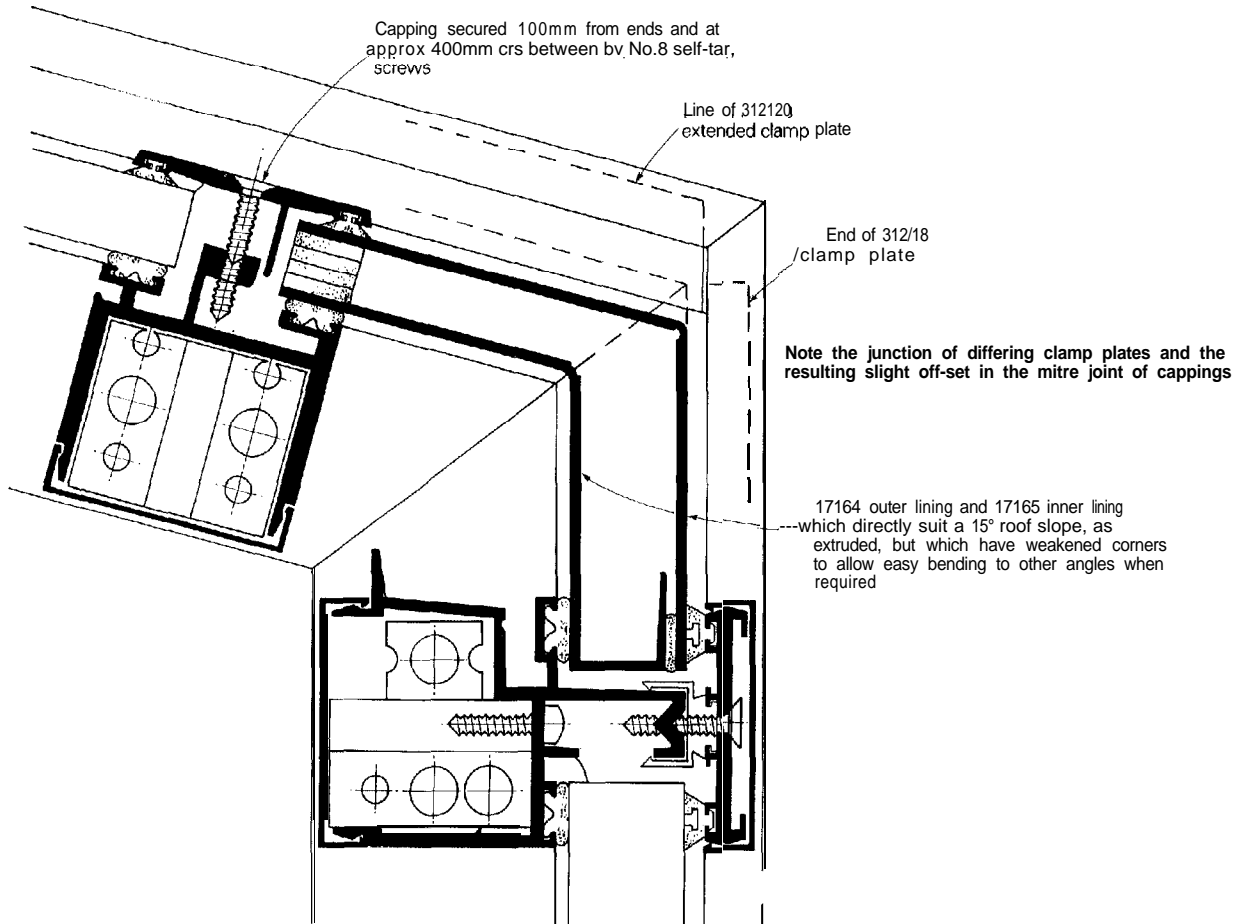

Eaves assembly (with gutter)

3121144 (15 x 31 self adhesive packing strip which insulates the eaves linings and is built up to appropriate thickness

Side flanges of 17131 capping cut back and top face dressed down to close off the mullion ends

105188 wedge gasket

312/23 stop end

17164
17165

17171 gutter profile engaged into clamp plate and locked in place by wedge gasket

Dotted indication of 17170 joint sleeve profile which is pressed home into sealant and clips under gutter shoulders

Glazing variations

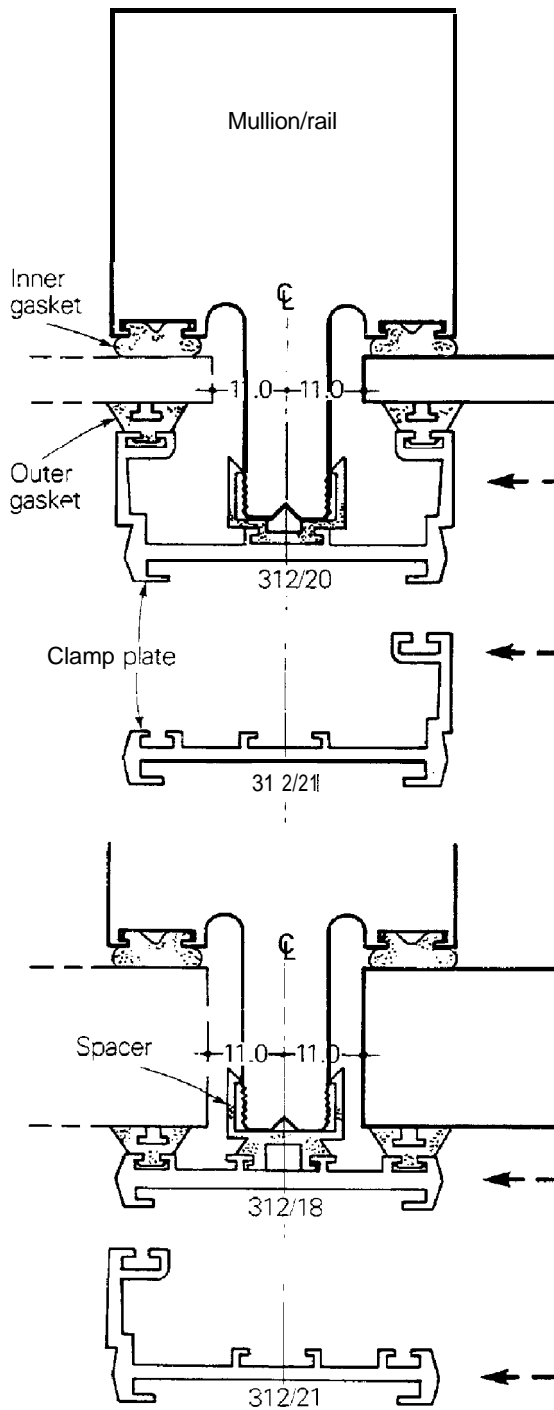

Glass mm	Spacer	Gaskets	
		Inner 105/-	Outer 105/-
5	17150	132	134
6	.	131	.
7	.	132	133
8	.	131	.
9	.	132	136
10	.	131	.
9	17152	132	134
10	.	131	.
11	.	132	133
12	.	131	.
13	.	132	136
14	.	131	.
13	17153	132	134
14	.	131	.
-15	.	132	133
16	.	131	.
17	.	132	136
18	.	131	.
19	17150	132	134
20	.	131	.
21	.	132	133
22	.	131	.
23	.	732	136
24	.	131	.
23	17152	132	134
24	.	131	.
-25	.	132	233
26	.	131	.
-27	.	132	136
2%	.	131	.
27	17753	132	134
28	.	131	.
-29	.	132	133
30	.	131	.
31	.	132	136
32	.	131	.

NOTES:

The design is based on a norm of 24mm thick glazing but can very simply be adapted to receive any thickness between 5 mm and 32 mm as indicated above. A considerable intermix of thicknesses is also possible, limited only by having to relate to the same spacer at any one member.

Any special conditions not covered above may be possible by increasing the outer gasket thickness as noted at the bottom of page 21,

Important: In areas where security against unauthorised infill removal is required the silicone head seal, illustrated on page 13, should be extended round the whole perimeter taking care not to block the outlets on any drained rails.

Parts list

Aluminium profiles

Part No.	Description
17100	74mm mullion
17101	134mm mullion
17102	94mm mullion
17103	114mm mullion
17106	Corner adaptor
17110	Normal rail
17111	Drained rail
17112	Bottom rail
17113	Narrow rail
17120	Sub-cill
17131	10mm capping
17133	Shouldered capping
17135	64mm capping
17136	108 mm capping
17144	Sleeve
17145	Reinforcement
17160	Roof rail
17161	Roof rail capping
17162	Ridge
17163	Ridge capping
17164	Eaves lining
17165	Eaves lining
17170	Gutter sleeve
17171	Gutter
17180/T	Roof vent
17181	Roof vent adaptor
2445	Flat 1" x 1/8"
2457	Angle 1/4" x 3/4" x 1/8"
17115	Channel 1" x 3/4" x 1/8"
2704	Bracket

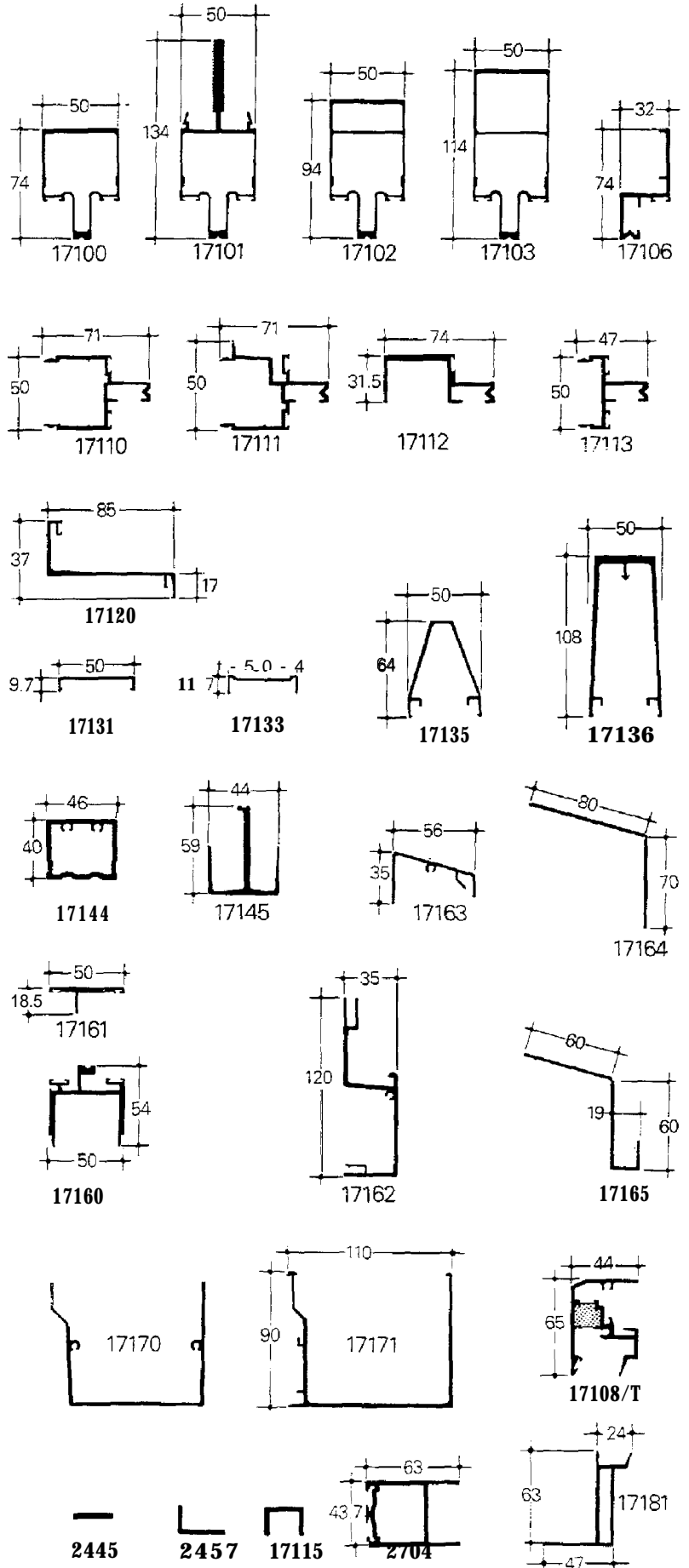

Components

Illustration	Part No.	Description
	312/2	Sub-cill joint cover (pressing)
	312/10	Normal rail bracket
	312/11	Bottom rail bracket
	312/12	Drained rail bracket
	312/13	Cill retainer
	312/14	15° ridge bracket (ex 2704)
	312/16	Spacer block
	312/17	Mullion plug
	312/18	Normal clamp plate
	312/19	Heavy duty clamp plate
	312/20	Extended clamp plate
	312/21	Unequal Clamp plate
	312/22	Ridge stop end
	312/23	Gutter stop end
	312/25	Roof rail bracket
	312/26	Narrow rail bracket
	312/27	Eaves bracket (ex 17145)
	312/28	Roof vent cleat
	312/29	Roof vent adaptor cleat
	314/16	Mullion bracket
	202/239	Tapping plate

fixings

Size	Head	Description
No.8 x 3/4"	PAN	S.S. self tapping (rail to bracket and stop ends)
No.8 x 3/4"	CSK	S.S. self tapping (roof rail capping)
No.8 x 1"	CSK	S.S. self tapping (roof rail capping)
No.8 x 1 1/4"	CSK	S.S. self tapping (roof rail capping)
No.10 x 1/2"	PAN	S.S. self tapping (bracket to mullion)
No.12x 1"	CSK	S.S. self tapping (clamp plate to mullion)
No.12 x 2"	PAN	S.S. self tapping (roof vent)
M8 x 20	Socket	S.S. set screw (ridge bracket)
M8	-	S.S. washer (ridge bracket)
M10x40	HEX	S.S. set screw (314/16 mullion bracket)
M10	HEX	S.S. look nut (314/16 mullion bracket)
M10	-	S.S. washer (314/16 mullion bracket)

Tools

Illustration	Part No.	Description
	312/150	Jig for rail bracket holes in mullions
	312/151	Jig for rail to bracket fixings
	312/153	Jig for drainage holes in rails
	312/154	Jig for roof rail capping fixing holes
	312/155	Jig for roof rail to bracket fixings
	312/156	Jig for ridge to bracket fixings and drainage
	314/152	Jig for sub-cill fixing holes
	312/360	Stepped drill for rail to bracket fixings (jig no 312/151)

Rigid P.V.C. profiles

Part No.	Description
17150	1 mm locatton spacer
17152	5 m m location spacer
77153	9 mm location spacer
17154	Roof light liner

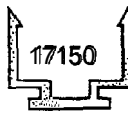

17150

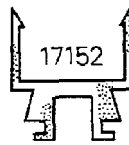

17152

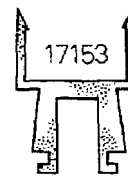

17153

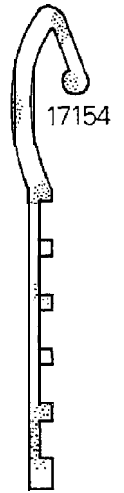

17154

Gaskets & Weatherseals

Part No.	Description
105/53	W/pile
105/76	18mm glazing gasket
105/77	6 mm glazing gasket
105/83	24mm glazing gasket
105/85	20mm glazing gasket
105/86	22mm glazing gasket
105/88	5mm wedge gasket
105/96	24.8mm glazing gasket
105/131	2mm inner gasket
105/132	3mm inner gasket
105/133	3mm outer gasket
105/134	5mm outer gasket
105/136	1 mm oufer gasket
105/141	Ridge seal
105/142	Insulation gasket
105/143	Ridge flashing
105/144	Packing strip



105/53



105188

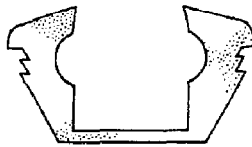

105/76

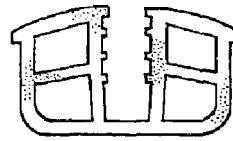

105/77

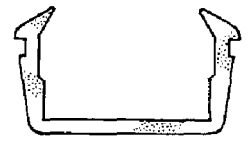

105/83

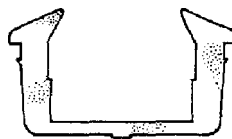

105/85

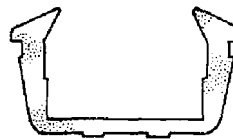

105/86



105/96



105/131



1051132



1051136



1051133



105/134 *

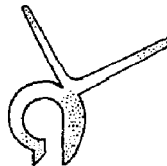

105/141



105/142

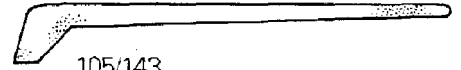

105/143

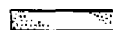

105/144 (15 x 3 double side adhesive)

*The central recess of the 105/134 aasket allows it to be nested on itself or receive either 105/136 or 133 gaskets. This allows the thickness of the outer gasket to be built up to cater for any special conditions not covered by the chart on page 18.



Sealants

The weathertightness of any curtain wall insulation depends entirely on the effective application of the seals.

The main extended seals are supplied by Glostal but the applied gun grade sealants are the responsibility of the fabricator and we give below specific details of the materials, or their equivalents, which we recommend should be used:

Tremco Proseal LM. silicone sealant:

For use to seal between any double glazed units and aluminium members. This is a neutral curing material which will avoid any possible interaction with the double glazing edge seal.

Tremco Proglaze silicone sealant:

For all other applications between infill and aluminium or at aluminium to aluminium junctions.

Tremco JS800 butyl sealant:

For sealing at inner gasket junctions, as para 5.4.4.

These products are available from:

Tremco Ltd., 86-88, Bestobell Road, Slough, Berks, SL1 4SZ Tel: 0753 691696

and they should be contacted for technical advice on perimeter seals or any other special conditions.

Adhesive

For use to 'lock' inner cappings where maximum strength is required as noted on pages 11 and 26 and page 41 para 4.4.

Permabond V501 (VOX)

This product is available from:

Permabond Adhesives Ltd., Woodside Road, Eastleigh, Hants. SO5 4EX Tel: (0703) 629628

Strength Calculations

Calculations for vertical and sloping members are closely related but additional factors have to be taken into account in the sloping areas. Full details are covered by British Standards CP3: CH5: Part 2, CP118, BS5516, BS6262 and BS8200., but the following notes are a simplified extract which covers all normal circumstances starting with the procedure for vertical curtain walling.

Stage 1: Gust speed

This must be established from the map in British Standard CP3: CH5: Part 2 which details the basic maximum 3 second gust speeds applicable in the UK in metres per second (m/s).

Stage 2: Gust speed adjustments (S^2 factor)

This gust speed should then be adjusted to take account of the surroundings and the height of the installation using Table 3 from CP3: CH5: Part 2, to establish an appropriate factor as summarised below:

Category -	1	2	3	4
Height				
3m	0.83	0.72	0.64	0.56
5m	0.88	0.79	0.70	0.60
10m	1.00	0.93	0.78	0.67
15m	1.03	1.00	0.88	0.74
20m	1.06	1.03	0.95	0.79
30m	1.09	1.07	1.01	0.90
40m	1.12	1.10	1.05	0.97
50m	1.14	1.12	1.08	1.02

Notes:

- Category 1: Open country with no obstructions
- Category 2: Open country with scattered windbreaks
- Category 3: Country with many windbreaks; small towns, outskirts of large cities
- Category 4: Surfaces with large and frequent obstructions, such as city centres.

The gust speed should be multiplied by this factor to arrive at the design gust speed.

Stage 3: Dynamic pressure

The basic pressure resulting from this design gust speed should now be calculated using the following formula:

Design gust speed squared and then multiplied by 0.673.

This gives a result in Pascals 'Pa' (N/m²)

Stage 4: Dynamic pressure adjustments

To take account of the effect which the building shape has on the basic dynamic

pressure it must be adjusted as detailed in CP3: CH5: Part 2.

A simplified summary is given in the table below:

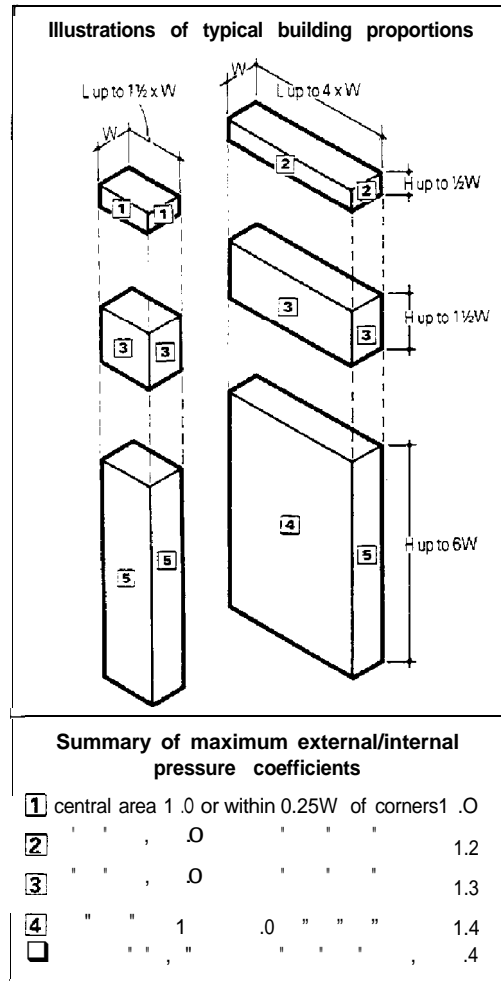

When multiplied by the appropriate factor from the above table it will give the design gust loading which can then be used to establish the inertia value necessary for any mullion or rail.

Stage 5: inertia value

The chart below should now be used to establish the Inertia value necessary for all the main mullions and rails by selecting the value related to the unsupported span of the member concerned

Span(m) / Value	Span(m) / Value	Span(m) / Value	Span(m) / Value
1.0 - 25	3.0 - 671	5.0 - 3106	7.0 - 8523
1.1 - 33	3.1 - 740	5.1 - 3296	7.1 - 8894
1.2 - 43	3.2 - 814	5.2 - 3494	7.2 - 9275
1.3 - 55	3.3 - 893	5.3 - 3699	7.3 - 9667
1.4 - 68	3.4 - 977	5.4 - 3913	7.4 - 10069
1.5 - 84	3.5 - 1065	5.5 - 4134	7.5 - 10483
1.6 - 101	3.6 - 1159	5.6 - 4364	7.6 - 10908
1.7 - 122	3.7 - 1259	5.7 - 4602	7.7 - 11344
1.8 - 145	3.8 - 1364	5.8 - 4848	7.8 - 11792
1.9 - 170	3.9 - 1474	5.9 - 5103	7.9 - 12251
2.0 - 199	4.0 - 1590	6.0 - 5367	8.0 - 12723
2.1 - 230	4.1 - 1713	6.1 - 5640	8.1 - 13206
2.2 - 265	4.2 - 1841	6.2 - 5922	8.2 - 13701
2.3 - 302	4.3 - 1976	6.3 - 6213	8.3 - 14208
2.4 - 341	4.4 - 2117	6.4 - 6513	8.4 - 14728
2.5 - 388	4.5 - 2264	6.5 - 6824	E - 1 5 2 6 0
2.6 - 436	4.6 - 2419	6.6 - 7144	8.6 - 15805
2.7 - 489	4.7 - 2580	6.7 - 7474	8.7 - 16363
2.8 - 545	4.8 - 2744	6.8 - 7813	8.8 - 16934
2.9 - 606	4.9 - 2923	6.9 - 8163	8.9 - 17518

The value should now be adjusted as follows:

Step a: multiply the value by the actual mullion or rail centres (or the spread of the load area supported) in **metres**

Step b: multiply by the actual design wind load in **pascals (N/m²)**

Step c: step b gives the required 'single glazed' value. If 'double glazed' it is necessary to multiply by 1.4

The resulting figure is the Inertia value (mm⁴/aluminium basis) necessary to support the maximum wind load on any mullion or rail with normal fixings at the extreme ends.

NOTE:

The max deflection used in the above chart is $\frac{1}{125}$ of the supporting members span-single glazed ($\frac{1}{175}$ double glazed). Should a smaller max. deflection be required or specified - then the inertia value must be a separate calculation.

Stage 6: Member selection

This Inertia value will allow the selection of the appropriate member from the details given on page 26

Variations for sloping areas



For sloping areas the calculations are a bit more involved because dead loads have an effect and must be allowed for so the procedure is as follows:

Stages 1 and 2

Exactly as detailed for vertical curtain walling to arrive at the design gust speed.

Stage 3a: Dynamic gust stresses

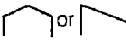
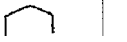
It is now necessary to turn the design gust speed into the pressure (+) or suction (-) which it will exert on the sloping area being considered. Many factors are involved but Table 7 in BS5516 gives figures which can be used for all normal circumstances as summarised below:

Angle of Slope from Horizontal	15° - 30		up to 45°			
						
Type of Slope	or					
Design Gust Speed m/s	Pressure	Suction	Pressure	Suction	Pressure	Suction
	20	0	423	184	325	0
25	0	661	287	508	0	584
30	0	952	414	731	0	841
35	0	1295	563	995	0	1145
40	0	1692	736	1300	0	1496
45	0	2141	931	1645	0	1993
50	0	2644	1149	2031	0	2337
55	0	3199	1391	2457	0	2828
60	0	3807	1655	2924	0	3365
65	10	4468	1942	3432	0	3950

(Note that the British Standard also covers steeper slopes if required)

This now gives directly the maximum stress (Pa) resulting from the wind gusts only.

Stage 4a: Dead loads

On sloping areas additional loadings must be taken into account in the pressure + direction and these are the dead loads of bars and infill, snow and any possible maintenance loadings.

Aluminium mullions and rails: To give a cover figure the weight for these should be taken as 25 Pa.

Glass: This should be taken as 25 Pa for every 1 mm of glass thickness over the whole sloping area.

Infill: The weight in this case must be obtained for the specific item from the suppliers.

Snow: Should be taken as 750%.

Maintenance: This can, in most cases, be discounted unless specific special equipment is involved

Stage 4b: Dead load effect

When all the dead loads are established they should be totalled up and multiplied by the cosine of the roof angle to arrive at their actual effect:

Actual dead load = total weight x cos. of roof angle.

Stage 4c: Maximum stress

It is now necessary to establish the maximum stress (pressure or suction) to which the roof will be subjected by doing two calculations:

Pressure (+): Gust Pressure (3a) plus Dead Load (4b)

Suction (-): Gust Suction (3a) minus Dead Load (4b). plus (750 x cos. of roof angle).

The largest result should be used for the remaining stages.

Stages 5 and 6:

Follow exactly the same procedure as detailed previously for vertical curtain walling to complete the calculations for the sloping members.

Notes:

The calculation procedures detailed are all based on the member concerned being fixed by normal type brackets at extreme ends (freely supported).

If an intermediate support occurs with the member running unbroken across it this will constitute a 'built in' condition which would reduce the required inertia value

In any such case the following factors should be applied to the stage 5 calculation result:

Member with one 'built in' end:
multiply by 0.600

Allowable Deflection of Sloping Mullions and Rails

The amounts built into our calculation notes are 1/125th span for single glazing and 1/175th span for double glazing, which are the applicable British Standard Allowances (BS 5516 E2) but in actual practice the Dead Loads cause a permanent sag which in many cases may not be visually acceptable. If it is required to reduce the amount of permanent sag we would suggest that the inertia value arrived at by Stage I-5 calculations should be increased by adding the result of 'inertia value multiplied by cosine of the roof angle (from horizontal)'.

Glass Requirements for Sloping Glazing:-

Where glass is used it is important to note the British Standard BS 5516 requires that safety glass must be used so that under impact it will either not break, break safely or be retained. (BS 5516 Appendix G).

Another important requirement is to take account of the fact that glass is weaker under long term sustained dead loads and to take account of this the aluminium, glass and snow loads should be multiplied by a factor of 2.6 for the pressure calculation when working out the glass thickness required. (See BS 5516 Note 13.2.1 and Tables 10 and 12).

Important:

in any case of doubt, or if any additional technical assistance is required, Glostal should be contacted.

Range Of inertia values (aluminium basis)

All values X
1,000mm⁴

Mullion conditions: note that in every case the values given incorporate a full length clamp plate (312118, 20 or 21) fully secured.

1	17100, 74mm box mullion	380
2	17102: 94mm box mullion	880
3	17103: 114mm box mullion	1564
4	17101 with 17135 clipfit inner capping	1722
5	17101 with 17135 adhesive-locked inner capping	2051
6	17101 with 17136 clip-fit inner capping	2550
7	17101 with 17136 adhesive-locked inner capping	5000

Mullion reinforcements: the following are members which can be added to the mullions identified to give increased strength.

8	17144: sleeve profile (mullions 1-7)	115
9	17145: reinforcement profile (mullions 1-7)	152
10	Steel flats; (mullions 6 & 7 only) these assemblies can accommodate steel flats as noted on Page 10, up to a maximum of two 100mm x 10mm. Aluminium basis values for each flat are as follows:	
	100mm x 6mm	1,500
	100mm x 8mm	2,000
	100mm x 10mm	2,500

Rail conditions: including full length clamp plate (312/18, 20 or 21) as standard.
An additional value is given when heavy duty clamp plate 312119 is used.

11	17110: normal rail with standard clamp plate	256
12	with heavy duty clamp plate	331
13	17111 drained rail with standard clamp plate	300
14	with heavy duty clamp plate	380
15	17112: bottom rail wrth standard clamp plate	398
16	with heavy duty clamp plate	492
17	17113: narrow rail with standard clamp plate	113
18	with heavy duty clamp plate	152
19	17160/17161: roof rail	84

Rail reinforcements: additive items for rails identified:

20	Structural steel hollow: 40 x 40 x 4 (rail 11)	121
----	--	-----

NOTES:

All the above values are for resistance to pressure and/or suction acting at right angles to the glazing. Rails are subjected to an additional 'sag' stress but in all normal circumstances it can be assumed that any assembly which is strong enough for the pressure/suction involved will also cater for sag.

The typical steel reinforcing members (10 & 16) are not supplied by Glostal, but are readily available from stockists. When steel is used it is very important that it is effectively rustproofed.

Other forms of reinforcement are possible and Glostal should be contacted for further advice when necessary.

Guidance Notes

- 2.1 312 (50mm) Curtain Wall has been developed following years of practical experience to extend the range of options available and provide a system with almost universal application.

All curtain walling, however, needs a great deal more care than a normal window installation and we have written the following notes as a general guide to the various factors which must be considered.

Building tolerances and movement

- 2.2 The openings, columns and floor beams of any building will wander out of position while being formed and even when finished can settle or flex.

In view of this it is very important to establish at the start the amount of tolerance or movement which the Curtain Wall must accommodate so that it can be allowed for.

Fixing anchorage points

- 2.3 Effective fixing of any curtain wall requires that the structure is accurately prepared. This normally involves the casting into concrete of channel type fixing inserts which will receive the fixing bolts, or the provision of supporting steelwork to which they can be attached.

It is very important that the necessary provision is agreed at an early stage and that acceptable positioning tolerances are agreed. The standard fixing bracket, 314116, for example, will allow for a variation of plus or minus 15mm in both vertical or in/out directions.

Curtain wall tolerances

- 2.4 Curtain wall members must be very accurately machined to ensure that there is no variation from the basic sizes

The 312 mullions are specially designed so that their side walls can flex to accommodate all horizontal thermal movement without any stress on rail seals.

Small vertical tolerances can be taken up at the sleeved mullion joints

Curtain wall thermal movement

- 2.5 The coefficient of thermal expansion for aluminium is 0.000024 per degree centigrade. This means that for the normal mid summer/winter temperature variation the length of any exposed aluminium could vary by as much as ± 1 mm for every 1000mm of length.

As mentioned in note 2.4, the Curtain Wall mullions have been designed to accommodate all horizontal thermal movement without any stress on the main seals and vertical thermal movement is catered for in two specific ways:

- a) In multi mullion height installations each mullion is 'hung' from fixings at the top and the bottom end has a sliding junction with the mullion below or onto the sub-cill.
- b) In single mullion height installations an alternative method can be used if preferred and this consists of allowing slightly extended mullions to rest on the sub-cill with all thermal movement accommodated at the head ('prop' condition).

Curtain wall wind loading

- 2.6 All Curtain Wall members and infill must be strong enough to support the maximum wind pressure or suction which results from the local wind gust speed and the building shape.

Full details are given in British Standard CP3, Chapter 5. Part 2 but pages 23-25 give a simplified procedure to allow for the correct selection of members.

Curtain wall fixings

- 2.7 The complete fixing arrangement at any one point must be capable of supporting at least twice the maximum loadings to which it may be subjected (wind load live and dead load).

The materials used must also be effectively protected against any danger of corrosion and wherever possible should be either aluminium or stainless steel. In certain areas, such as London, the use of rustproofed steel may not be permitted.

The standard 314116 bracket when attached to the 17001 mullion with three M10 stainless steel screws can safely support a wind or dead load of 5.8KN but the actual safe load will in most cases be dictated by the strength of its attachment to the structure.

Curtain wall fire resistance

- 2.8 The 312 Curtain Walling will not support the spread of fire but in itself it has no significant fire resistance aluminium melts at around 660°C.

This means that wherever fire resistance is a specific requirement, it must be achieved either by the provision of back up walls or the use of suitable infill panels with independent fire resistant fixings.

It is the specifier's responsibility to detail the precise requirements and, as these will vary from one area to another, they should be cleared at an early stage.

Curtain wall weather performance

- 2.9 Resistance to air and water penetration of the main Curtain Wall structure will meet the maximum requirements of BS 6375. Part 1 1981. It will also meet the wind resistance requirements, as detailed in para. 2.6.

The weather performance of any opening

lights or infill will obviously be at the level of the unit concerned.

Important: Water is far more likely to penetrate through any sloping areas because gravity also comes into play, so it is vital that very special care is taken in these areas to ensure that all seals are 100% effective.

Curtain wall sloping areas

- 2.10 All sloping mullions must be in one unbroken length because effective sleeved joints are not possible. This limits the maximum sloping span to 6,000 mm.

Vertical Glazing/Mill

- 2.11 All glass thicknesses must comply with BS6262, and confirmation of their suitability for any other infill material must be obtained from the supplier.
- 2.12 The dry gaskets allow for easy fitting but in any areas where security is important an applied silicone seal should run round the whole pane, as noted on Page 18.

Sloping Glazing/Infill

- 2.13 Only safety glazing should be used and the glass thickness must allow for the greater stress caused by sustained dead loads, as detailed in BS5516 (para 13.2.1). Confirmation must be obtained from the supplier of the suitability of any other type of infill material.

Important: Because the water seals are more critical in sloping areas it is important that the surfaces of any infill are smooth and firm at the contact point. Cavity polycarbonate sheet, for example, must have side edges cut close to connecting webs, or be supported. The cavities must also be closed off at the head of each pane.

British Standards

- 2.14 Fabricators should obtain copies of the following relevant British Standards for reference:
- CP3 Chapter 5 Part 2: Wind Loadings
 - CP118: Structural Use of Aluminium
 - BS 5516: Patent Glazing
 - BS 6262: Glazing
 - BS 8200: External Building Enclosure (Curtain Walling)

Important note

- 2.15 If any further guidance or information is required Glostal should be contacted.

Workshop data

Preparation of mullions

In most cases profile 77700 is illustrated but details apply equally to all other mullions, notes 3.1-3.15.

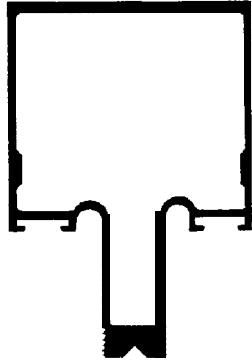

- 3.3 With extended mullions (17101, 2 & 3) it is necessary to cut back behind the back wall of the front tube to allow the sub-cill upstand to run through. It may also be necessary to form this cut back as a slot to give an acceptable connection to the inside structure, as shown on the typical illustration below.

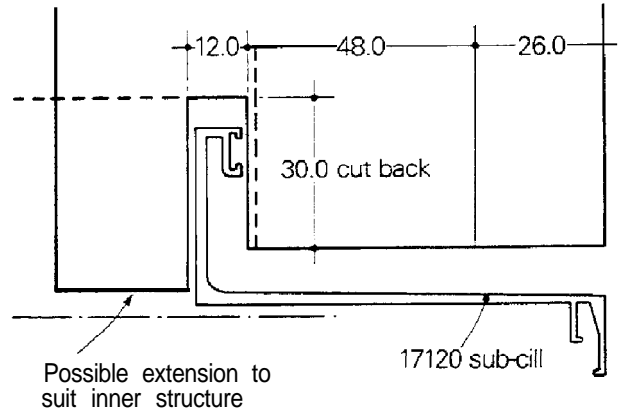

- 3.1 Mullion profiles are used as the main members in both vertical and sloping glazing and need the following preparations:
- 3.2 **At sub-cill:** An allowance of either 71 mm for 'hung' construction (page 13) or 7 mm for 'prop' construction (page 9) is taken from the underside of the sub-4 profile, and the end square cut and drilled for bottom rail bracket as detailed below:

- 3.4 **For normal, narrow & drained rails:** The centres of these rails should be marked on the mullion and preparation to receive the brackets should be carried out as detailed below:

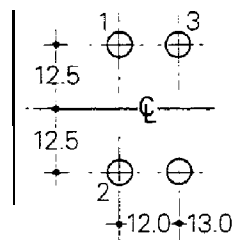
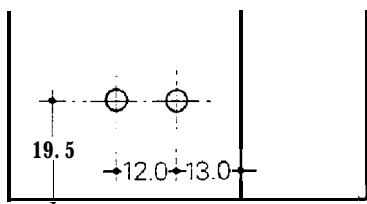

For normal rail bracket 312/10 drill all holes
 For narrow rail bracket 312/26 omit holes 1 & 2
 For drained rail bracket 312/12 omit hole 3

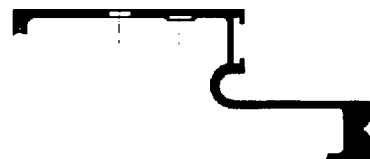
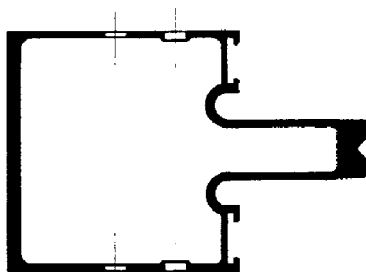

4.2mm dia holes to receive No.10 x 1/2" pan hd self-tap screws securing 312/1 bottom rail brackets.
 Jig No. 312/150.

4.2 mm dia holes to receive No.10x 1/2" pan hd self-tap screws securing 312/10 normal, 312126 narrow or 312/12 drained rail brackets.
 Jig No. 312/150

- 3.5 **For normal head detail** (as pages 5 & 9):
The necessary clearance (hung) or expansion gap (prop) should be allowed and the mullion end square cut with nose machined back to allow the 2458 lining to run through, then drill for top rail bracket as detailed below:

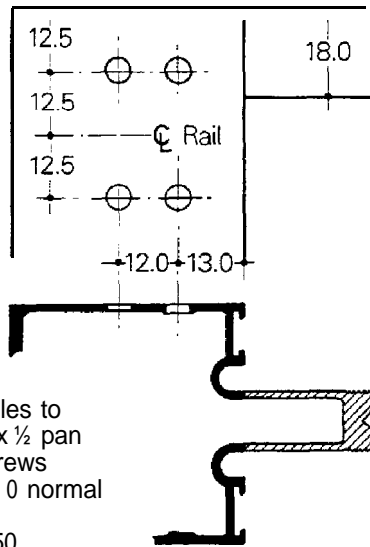

4.2mm dia holes to receive No.10x 1/2 pan hd self-tap screws securing 312/10 normal rail bracket.
Jig No. 3121150

Note that if the type of head fixing bracket illustrated on page 9 is used to secure the top of 'prop' condition mullions it may also be necessary to recess the back flange/s of mullions to allow for the thickness of the projecting base plate.

- 3.6 **For sleeved mullion junction** (page 8): In all cases the end of the lower mullion is cut square at the closest point to the fixing which will ensure a satisfactory anchorage for fixing bolts and allow free movement for the 17144 mullion sleeve if angle fixing brackets bolting through the main tube are used (page 9).

The end of the upper mullion is also cut square, allowing a nominal 5mm expansion gap between the mullions for 'hung' construction, but a tight, metal to metal, fit if the upper mullion is to be in a 'prop' condition.

As detailed on page 8, 13mm dia outlet/ventilation holes are drilled through the nose of the upper mullion, 155 mm up from the bottom and just in front of the shoulders, and then two 312/17 mullion plugs are carefully fitted to form a completely

watertight seal (recess the first plug slightly into the mullion, apply a generous coating of silicone onto its surface, then enter the second plug and push them both carefully into their final position).

This is done so that any water within the main mullion tube can drain out through the 13mm dia holes into the front area.

A 200mm length of mullion sleeve, 17144, is now fitted so that it butts against the underside of the mullion plug and is secured in place by self-tapping screws.

IMPORTANT NOTE:

This sleeved mullion junction is only applicable on vertical glazing and must not be used on any sloping glazing where mullions must always be in one, unbroken, length.

- 3.7 **For fixing brackets** (pages 8 & 9): These must be made from materials which will not corrode and can be fixed to both structure and curtain walling in such a way that they will safely withstand at least twice the maximum design loadings.

Our standard bracket 314116 is typical being formed from an aluminium extrusion prepared for M10 stainless steel bolts.

The initial mullion preparation in this case (mullion 17101) consists of forming a slotted hole in the serrated back fin. To allow for initial mullion positioning (the 11 mm top and bottom holes are drilled on site to lock the whole assembly with the final M10 bolts).

This should be a 40mmx 11 mm slotted hole positioned in line with the centre of the 314/16 bracket and 15mm in from the back as illustrated.

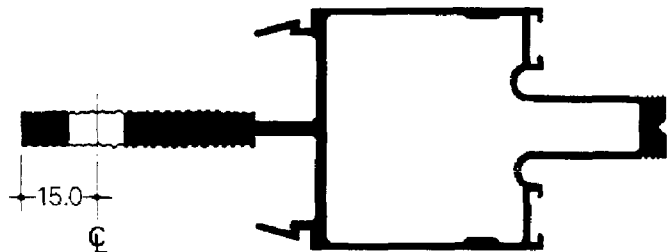

- 3.8 At **eaves junction** (pages 16 & 17): At this detail the vertical and sloping mullions are cut at an angle to form a perfect mitre to suit the angle of roof slope and are then prepared to receive roof rail, drained rail and eaves junction bracket, 312/27, as detailed below.

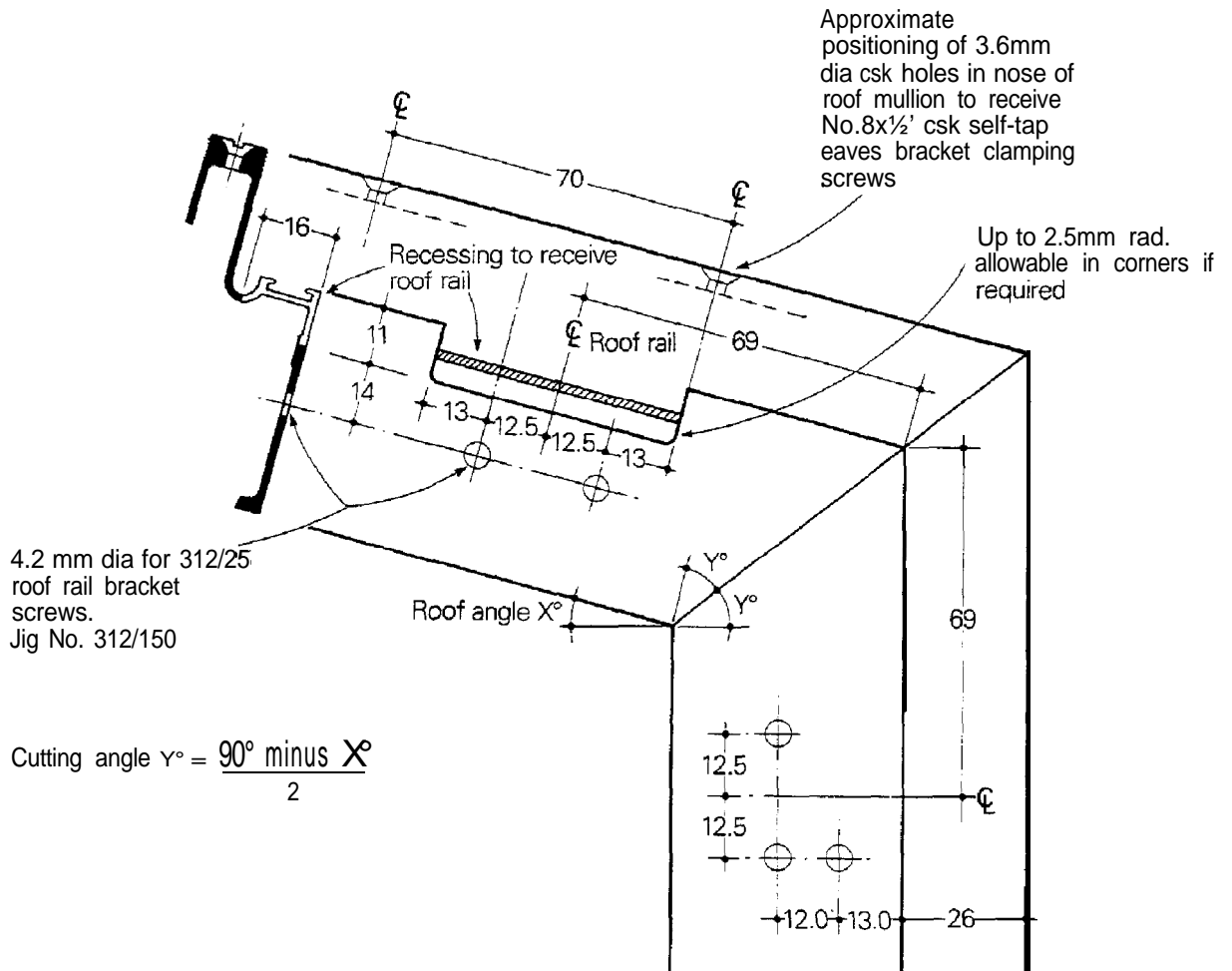

Note that all dimensions are related to the shoulders of the mullions which means that an allowance must be made for the nose projection (26mm) when working out o/all cutting sizes. (Actual extra will be $26 \times \tan Y$)

- 3.9 For roof rails (page 151: The preparation to receive the ends of roof rails and the 312125 brackets will be exactly as detailed under 3.8 and as shown on the sketch assembly below which also illustrates the roof rail & bracket.

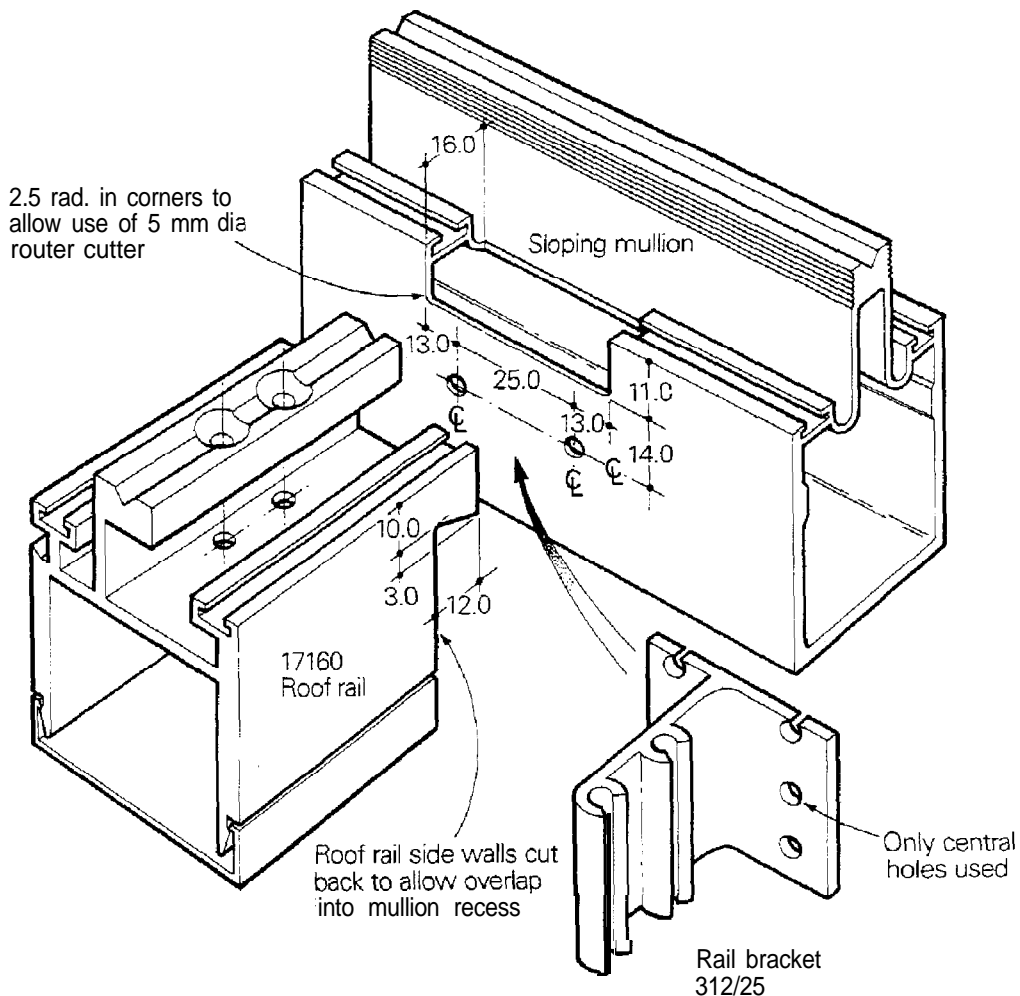

- 3.10 Sloping mullion drainage:** Any water penetration at roof rails or ridge is collected by the recesses in those members and drained into the main tube of the mullion via the drain holes in the ridge and the rail recesses.

Any water penetration along the length of the sloping mullions is collected in the curved recesses of the mullion shoulders, but this also needs to be drained through into the main tube at not more than 1500mm centres.

This should be done by cutting 20mm x 5mm slots immediately above (within 50mm of) any roof rail preparation, and at intermediate points if necessary.

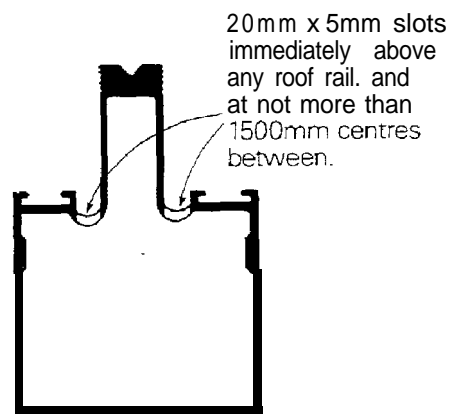

Corner adaptor 17106

(pages 6 & 12)

- 3.11 This profile is fitted onto the side of mullion 77100 to avoid the need for double mullions at 90° corners or gable conditions.

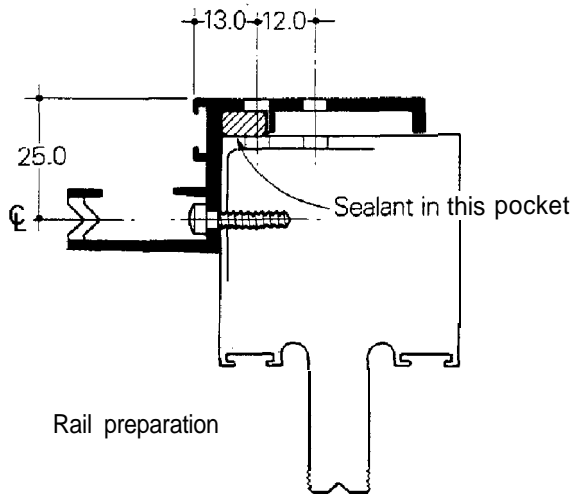

- 3.12 It should be cut as necessary to match the mullion to which it is attached and then be fixed and sealed onto it by No.8x3/4" pan hd self-tapping screws at approx 400 mm ctrs fixing through preparation similar to that for rail end fixing (para 3.21).

Note that care must be taken to avoid clamp plate fixing centres.

- 3.13 Preparation should then be carried out for any rail brackets, as covered by paras 3.2, 4 & 5.



Mullion to ridge relationship

(page 15)

- 3.14 At this detail the sloping mullion is cut off at the roof angle and positioned so that the mullion shoulders are just proud of the 6mm dia bulb on the ridge upstand. See detail under para 3.56.
- 3.15 5.0mm dia holes should be drilled in the sides of the mullion to pass the No.10 screws fixing through into the ridge bracket (see detail above para 3.56).

Normal rail profile 17110

(page 13)

- 3.16 This profile should be cut square to the required length and drilled for end fixing screws as follows:
- 3.17 Length formula.
Mullion centres minus 50mm +0, -0.5.
- 3.18 Two 4.5 mm dia holes  and two 9.0mm dia access holes  should be accurately drilled at each end at detailed centres.

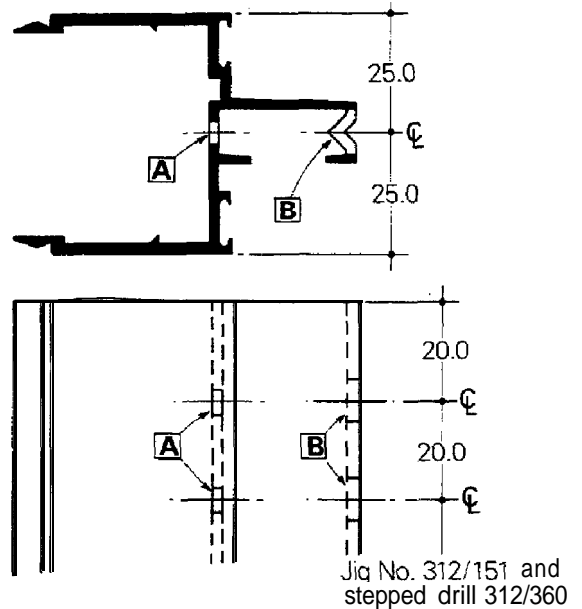

Drained rail profile 17111

(page 13)

- 3.19 This profile must be cut square to the required length, then be drilled and slotted for end fixing and drainage.
- 3.20 Length formula:
Mullion centres minus 50mm +0, -0.5.

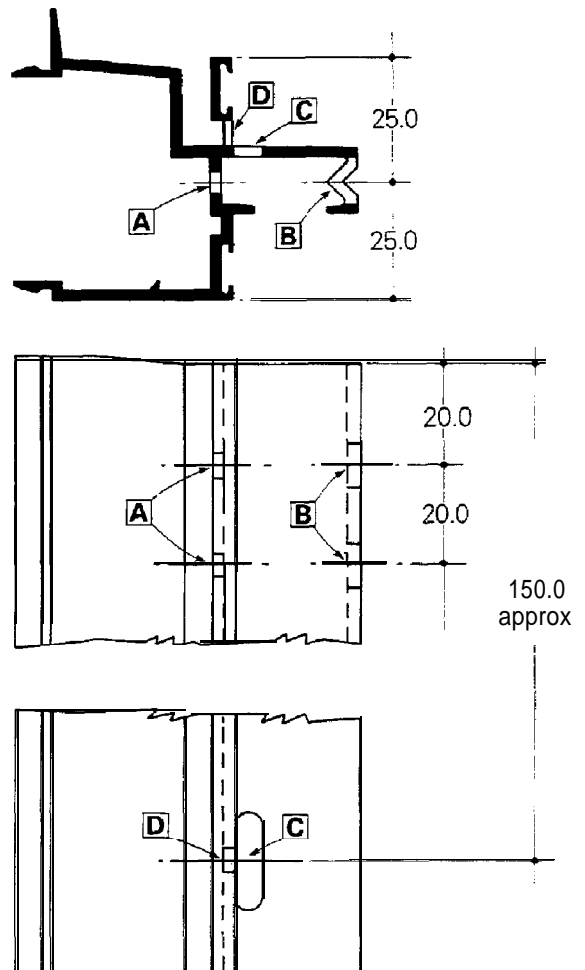

- 3.21 Drill two 4.5 mm dia holes **A** and two 9 mm dia access holes **B**, all accurately positioned at each end of rail to allow for rail to bracket fixing screws.
Jig No. 3121151 and stepped drill 3121360.
- 3.22 Approximately 150 mm in from each end, cut a 20mmx6mm (minimum) slot **C** and then drill a 5 mm dia drainage hole **D** immediately above, taking great care with the drill travel to avoid penetrating the inner flange.
Jig No. 312/1 53.

Bottom rail profile 17112

(page 13)

- 3.23 This profile should be prepared exactly as detailed in paras 3.15-17 for the 17110 rail.

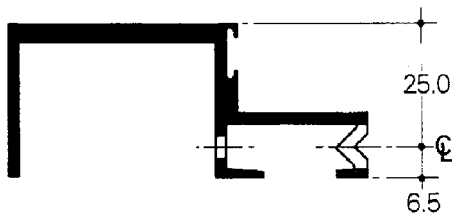

Narrow rail profile 17113

- 3.24 This profile should be prepared exactly as detailed in paras 3.15-17 for the 17110 rail.

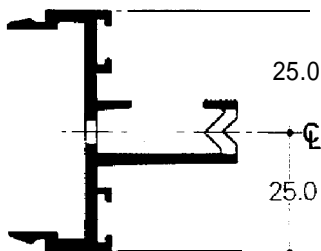

Clamp plates 312/18,19,20 & 21

(pages 10, 11, 13 & 18)

- 3.25 These are supplied in pre-punched lengths which must be cut to the required length for the mullion or rail involved

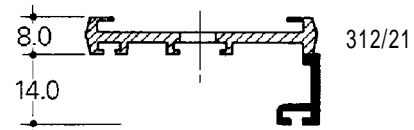
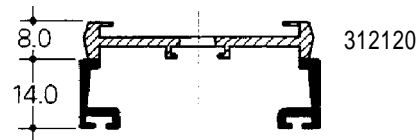

- 3.26 Mullion length:
Special end shaping will be required at a mitred eaves condition, as indicated on pages 16 & 17, but in all other cases the clamp plate will be square cut to the same length as the mullion to which it is attached. This is important because the clamp plate contributes to the total strength of the mullion assembly.
- 3.27 Rail length formula:
3121'18 & 19:
mullion centres minus 55mm square cut.
312/20 & 21:
mullion centres minus 51 mm +0, -0.5, with the hatched portions machined back by about 2 mm at each end to allow for the application of mullion cappings.
- 3.28 The cutting should be arranged so that the first fixing hole is no more than 50mm from the end and additional 7.5mm dia holes should be added if necessary to achieve this.
- 3.29 Where a gutter is fitted (page 17), it will be necessary to finish the mullion clamp plate just below the bottom of the gutter to allow it to run through.
- 3.30 It could be an advantage to pre-fit the clamp plates to the mullion or rail on which they are to be used, by sliding the appropriate spacer. 17150, 52 or 53, into the clamp plate, applying it to the mullion/rail nose and using it as a jig to drill the 4.8mm dia attachment holes. The clamp plate can then be temporarily held in place by local No.12x 1" csk self-tap screws.

- 3.31 if required, the appropriate outer gasket, 1051133, 134 or 136, can also be fitted at this stage, with overhangs at ends (for final trimming on site) and a smear of adhesive at ends to secure. Care must be taken not to stretch when applying.
- 3.32 **IMPORTANT NOTE:** 312/19 should only be used as a reinforcement for rails and its use is limited to applications with consistent glass thicknesses in the 19mm-32mm range (unequal versions are not available). Any application to mullions must be cleared as satisfactory with Glostal.

Sub-cill profile 17120

(page 13)

- 3.33 This profile should run in lengths which are as long as possible, allowing approximately a 3 mm gap at jambs, but metal to metal joints at any intermediate junctions. Intermediate junctions should occur about 200mm away from any fixing centre.

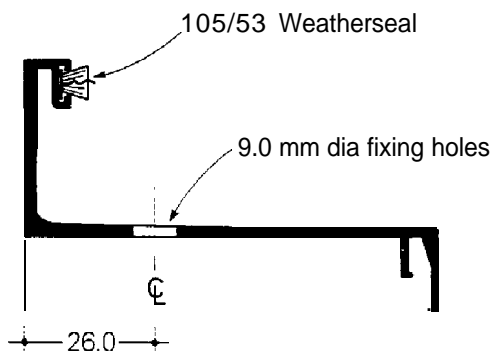

- 3.34 The 9mm dia fixing holes should be positioned exactly at all mullion centres and at not more than 400mm centres between. Note that a 312/13 cill retainer will be fitted at each fixing to retain the mullions and bottom rail, plug the hole and receive the fixing screw at the time of installation. Jig No. 314/152
- 3.35 At this stage the 105/53 weatharseal can be fitted and held in place by crimping or adhesive, allowing a small overhang at ends for final trimming when fixed on site.

Rail capping profile 17131

(page 13)

- 3.36 This profile is used on the outside and also on the inside where the rails are exposed, ends square cut.



- 3.37 Length formula:
Mullion centres minus 51 mm +0, -0.5 for both inside and outside applications.

Mullion capping profile 17133

(pages 10 & 11)

- 3.38 This is used as the basic capping on the outside of mullion assemblies, ends square cut.



- 3.39 Length
In normal circumstances the capping should line through with the extreme top & bottom of the curtain wall and should then run in the longest suitable lengths between.

An exception is the special shapings which are necessary at the eaves condition as indicated on pages 16 & 17.

Another exception is where the cut ends of clamp plate and mullion capping would be exposed to view at the bottom of any installation. Here we would suggest that both the mullion clamp plate and capping should be finished short and the bottom rail capping (using profile 17133) should run through continuously.

IMPORTANT:
intermediate joints should occur at least 100 mm below any mullion clamp plate joints and a gap must be allowed to cater for thermal expansion - at least 1 mm for every 1000mm of length.

- 3.40 Note on page 17, that where a gutter is fitted the roof mullion capping should be changed to profile 17131, so that its main face can be dressed down to mask the exposed clamp plate and capping ends.

Mullion capping profile 17135

(pages 10 & 11)

- 3.41 This profile is normally used to clip onto exposed inner portions of mullion 17101, but it can also be used as a reinforcement if run for the full height or as an outer feature capping if required.

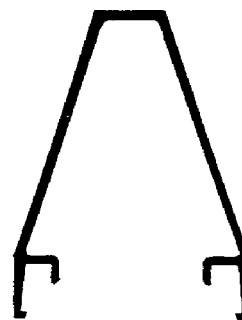

- 3.42 Length :
inside - in this case it is either cut to give a close fit to the top & bottom conditions in the exposed area, or used as a reinforcement running the full mullion length (see page 26).

Outside – as detailed for 17133 in para 3.39 with extreme top & bottom ends shaped to suit the structural surround conditions.

Where joints occur it will be necessary to form a pressed inner joint cover to back up the mastic seal.

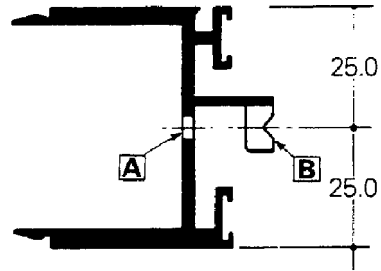

Mullion capping profile 17136
(page 10)

3.43 This profile is used in exactly the same way as 17135 above but its large site allows for greater mullion reinforcement either on its own (clip-fit or adhesive applied) or in conjunction with steel reinforcement (see page 26).

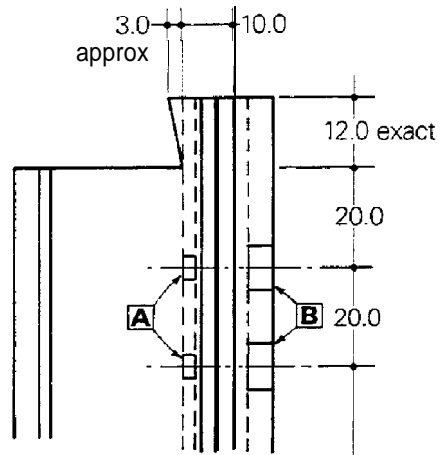
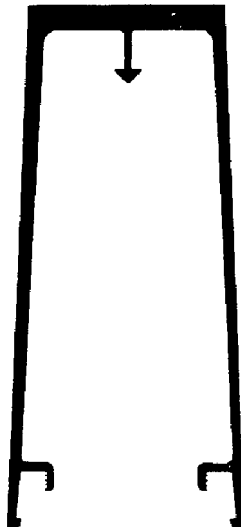

3.48 Two 4.5 mm dia holes **A** and two 9.0 mm dia access holes **B** should be accurately drilled at each end as detailed. Jig No. 3121155 and stepped drill 3121360

Roof rail capping profile 17161

3.49 This profile to be cut square at each end and be prepared with countersunk holes to allow fixing to the roof rail.

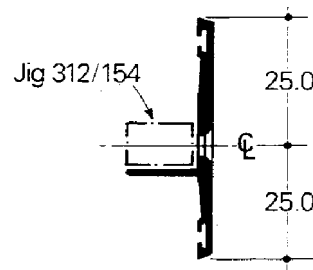

GENERAL NOTE:

3.44 In certain cases, such as the intermediate expansion joints between cappings, the cut ends of profiles will be partly exposed and these will need to be touched up if considered necessary.

Roof rail profile 17160
(pages 15, 16 & 17)

3.45 This profile must be shaped at each end to extend into the roof mullions and be drilled to allow for end fixings (see sketch with para 3.9).

3.46 Length formula:
Mullion centres minus 26mm +0 -0.5.

3.47 End shaping consists of cutting back the rail side walls by exactly 12mm with a 3mm slope towards the ends as illustrated.

3.50 Length formula:
Mullion centres minus 51 mm +0. -0.5 to provide a close fit between mullion cappings.

3.51 4.4mm dia csk holes should be drilled 70mm in from each end with additional holes along its length as necessary at no more than 400mm ctrs. Jig No. 3121154

3.52 It could be an advantage if the roof rail capping is pre-fitted to the roof rail on which it will be used by drilling 3.6mm dia holes in the rail nose, using the capping as a jig and temporarily securing with No.8 csk self-tap screws.

3.53 If required the 10.51136 outer gasket could also be fitted at this stage with overhangs at ends (for final trimming on site) and a smear of adhesive at ends to secure. Care must be taken not to stretch when applying.

Ridge profile 17162

(pages 6 & 15)

- 3.54 This profile is used either singly, as a wall plate, or double, as a ridge and it should run un-broken for the full length of the detail. If conditions dictate that joints are necessary, care must be taken to ensure that no water is able to overflow from the shoulder drainage area.
- 3.55 At roof mullion centres, 8.5mm dia holes should be accurately drilled for the mullion fixing bracket (312114 for standard 15° slope) and 6mm x 25mm drainage slots as illustrated.

Ridge capping profile 17163

- 3.57 This profile is square cut to exactly the same length as the ridge profile 17162 in all normal circumstances.

No other preparation is necessary.

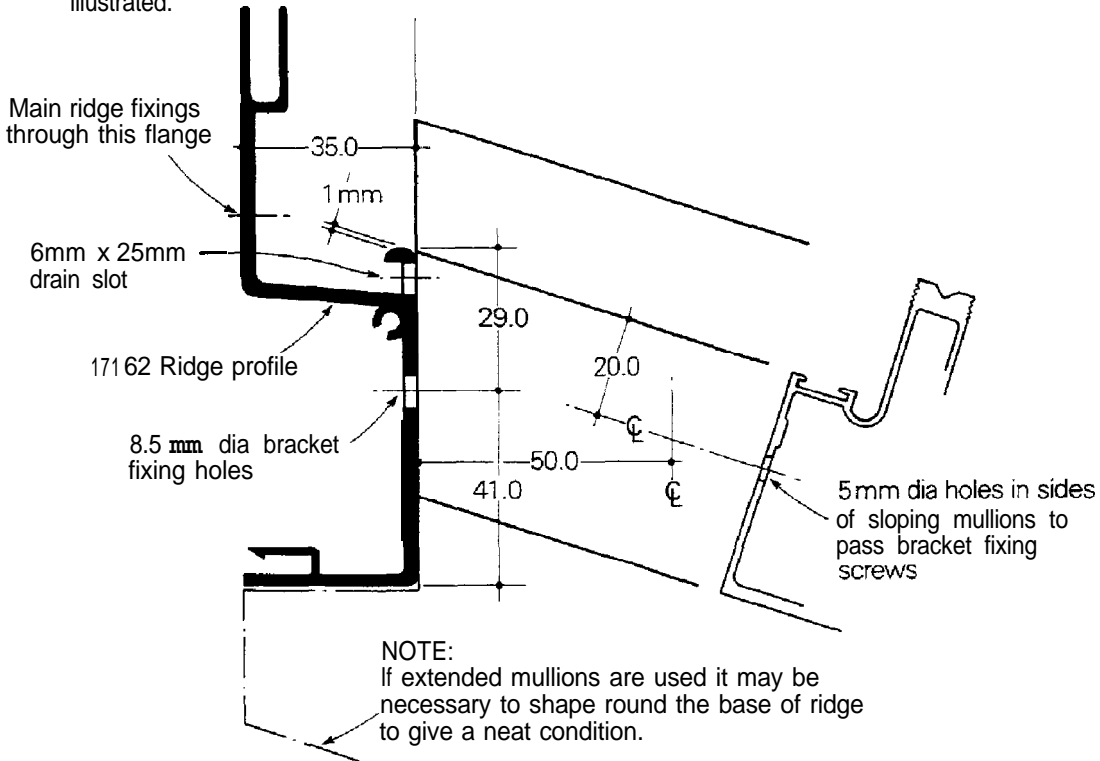
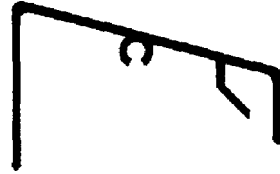

- 3.56 Preparation for the main ridge fixing screws should be carried out as necessary in the vertical flange. Would suggest a minimum size of No.12 or M6, at a maximum of 500 mm ctrs.

Special ridge brackets

(page 15)

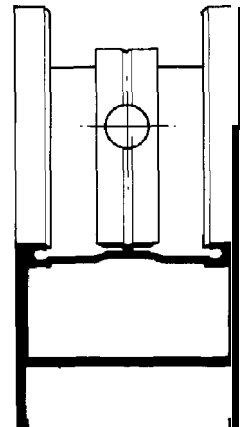
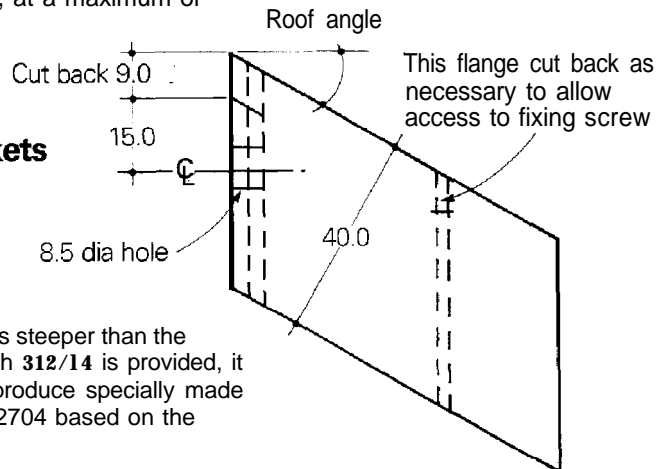

- 3.58 When the roof slope is steeper than the standard 15°, for which 312/14 is provided, it will be necessary to produce specially made brackets from profile 2704 based on the details given below.

Wherever a roof mullion stronger than the basic 17100 is necessary, additional fixings must be arranged to increase the strength of the mullion attachment

Eaves lining profiles 17164 & 5

(pages 16 & 17)

3.59 These profiles are square cut to the required length and then, if to suit a 15° roof slope, are jointed by applying **105/144** double sided adhesive tape – one thickness at bottom and sufficient layers to match the roof glazing thickness at the top, as shown on typical illustration.

Ends should also be closed off using 105/144 tape although it is not necessary to form a complete seal.

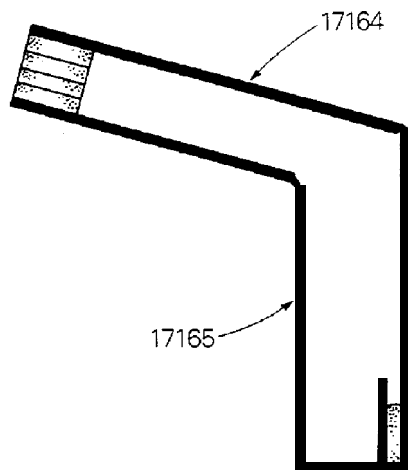

3.60 Length formula:
Mullion centres minus 22mm i-0, -0.5.

3.61 These profiles can both also be used for other roof angles up to approximately 30° because the weakened corners will allow the profiles to be opened up to the required angle.

The inner, 17165, lining can be opened up to suit steeper roof angles, up to 45°. but the outer lining may have to be replaced by a pressing if the angle and glazing thicknesses make the extruded outer, 17164, lining unsuitable.

An accurate setting out will confirm requirements for any specific angle and glazing arrangement.

Gutter sleeve profile 17170

(pages 7 & 17)

3.62 This profile is a clip-fit into the gutter profile when fitted against mastic seals and should be used in 150mm lengths to form joint sleeves and receive stop ends to suit specific conditions.

Gutter profile 17171

(pages 7 & 17)

3.63 This profile is shaped so that it engages into the rail clamp plates and is then locked in place by fitting 105/88 wedge between the inner upstand and the outer eaves lining.

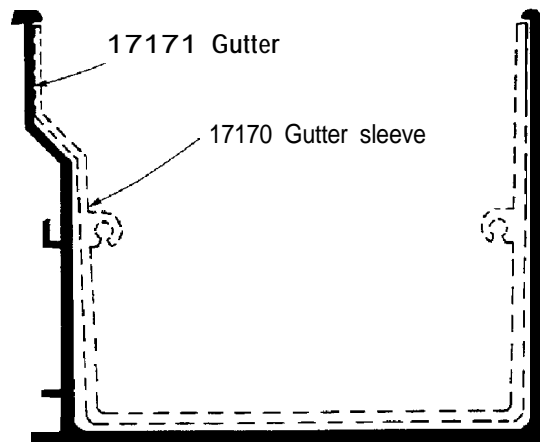

3.64 It should run in the longest possible lengths with any joints positioned, if possible, at mullion centres. Gaps should be allowed at all main junctions to cater for thermal movement of about 1 mm for every 1000mm of length.

3.65 Gutter angles are formed by welding up a gutter sleeve to the required angle using profile 17170 and the gutter can then be accurately mitre cut and butt jointed using the fabricated sleeve to secure and seal the joint.

3.66 Gutter outlets can be formed to suit the downpipe being used by cutting a hole to match the inner core shape of the downpipe sleeve profile and securing the sleeve in place either by welding or by local angle brackets lipping over into the gutter, then sealing round the underside with silicone. On rectangular profile downpipes these brackets can run the full width of the sides in line with the gutter to avoid any restriction of water flow. As sketch below.

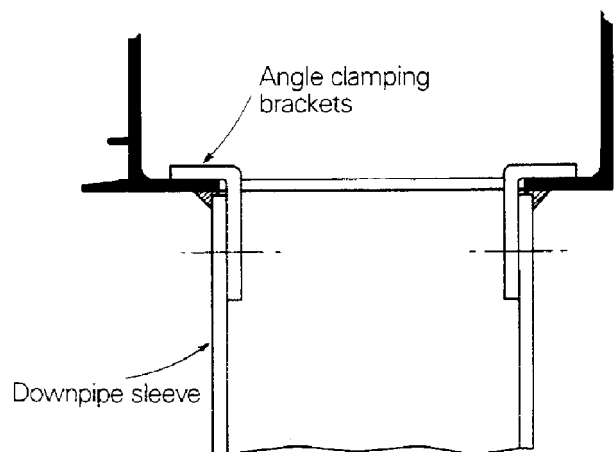

See section 6 for further downpipe information.

Roof vent profile 171800/T

(page 14)

- 3.67 This profile is to be accurately mitre cut to form the frame corners. The top & bottom members are drilled for corner screws, the top member should be fitted with hinge retainer and the bottom member drilled for drainage.

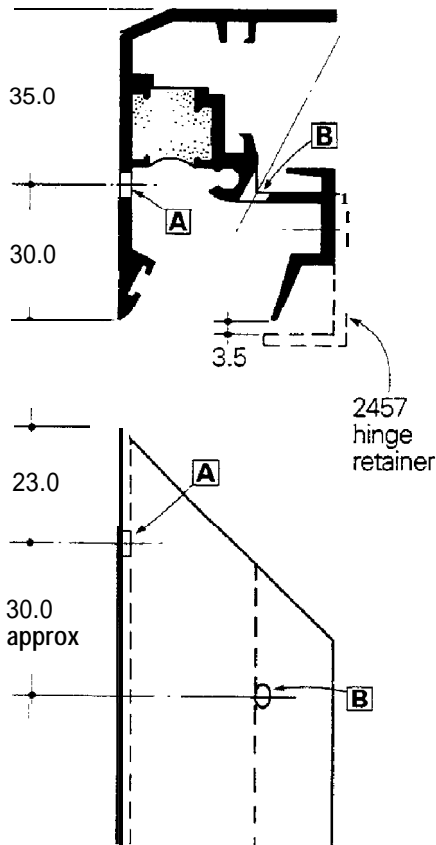

- 3.68 Length formula:
The overall of all members should be mullion/rail centres minus 66mm +0, -0.5.
- 3.69 Top & bottom members should now have 5.8mm dia holes drilled near each corner to pass the No.1 2 self-tap screws **A**
- 3.70 The top member should be fitted with a hinge retainer formed from angle profile 2457 positioned as detailed and firmly secured by No.10x½" pan hd self-tap screws at no more than 300mm ctrs.
Hinge retainer should be #mm shorter than the top member so that it lines with the inner edge of the mitre.
- 3.71 The bottom member should now have 6 mm dia drain holes **B** drilled through near each corner at an angle to allow access and practical drilling.
- 3.72 The bottom member will also need to be prepared to receive the opener which will be used.
- 3.73 Glass sizes for the roof vent should be taken as mullion/rail centres minus 130mm +0mm. -3mm.

Roof vent adaptor profile 17181

(page 14)

- 3.74 This profile is to be accurately mitre cut to form the adaptor corners, the bottom member will be drilled for drainage and all will be fitted with 17154 liner and glazing angle 2457 secured at no more than 200mm ctrs.

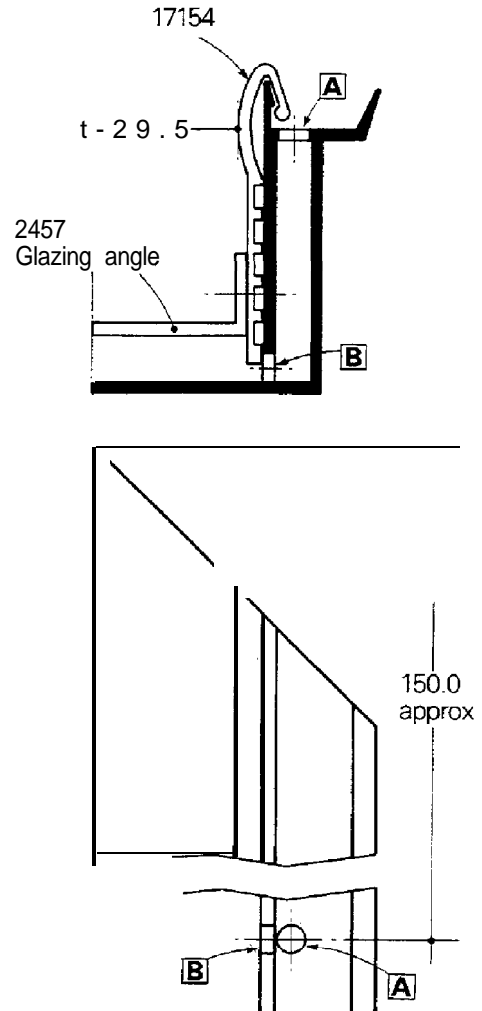

- 3.75 Length formula:
The overall of all 17181 members will be mullion/rail centres minus 22 mm +0, -0.5.
- 3.75 The bottom member should have 6mm dia drain holes **A** & **B** positioned about 150 mm in from each end.
- 3.77 All members should now be fully prepared with mitred 17154 U.P.V.C. linings and 2457 angle positioned to clamp the lining in place and match the roof glazing thickness.
The 2457 angles will have the same overall lengths as the 17181 adaptor profile.
The size allowance for the 17154 liner is noted on the profile illustration.
- 3.78 The bottom member will also need to be prepared to receive the opener which will be used.

Workshop Assembly Notes

Vertical and sloping mullions

- 4.1 In addition to the preparation for and partial prefitting of clamp plates, para 3.30 and the fitting of any mullion sleeves, para 3.6.. any required reinforcement should also be fitted into place as noted below
- 4.2 17144 Sleeve **profile**: This should only be used on vertical mullions because profile 17145 is more appropriate for sloping mullions.

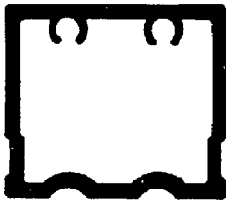

It should run for the total length of the mullion assembly concerned, but where there is a sleeved joint it should finish against the mullion plugs at the bottom and, if there is to be a sleeved joint above, about 120mm short at the top (para 3.6 and page 81.

Also finish about 150mm short of any mitred eaves junction to allow for the 312127 eaves bracket, para 4.8.

Once in its correct position it should be secured.

Note that rail bracket preparation affects this profile and should be carried out when it is in place, (paras 3.2, 3.4 & 3.5.)

- 4.3 17145 Reinforcement: This can be used on both sloping and vertical mullions as required.



On vertical mullions it should be used in a similar manner to the 17144 profile, (para 4.2) but is secured by clamping screws through the mullion nose, as para 4.8.
On sloping mullions it should finish about 100mm short at the ridge detail, to allow for the ridge bracket, (page 15) and about 150mm short at the mitred eaves, to allow for the eaves bracket 312/27, (para 4.8).

Note that this profile is affected by any roof rail bracket preparation and this should be carried out when it is in place, (para 3.9).

- 4.4 **Adhesive** locked profiles 17135 & 17136: Where used as a reinforcement and where the maximum strength possible is required they should be pre-fitted and locked to the mullion by applying adhesive into the two capping pockets, pressing home into position and then clearing off any excess on the exposed surfaces.

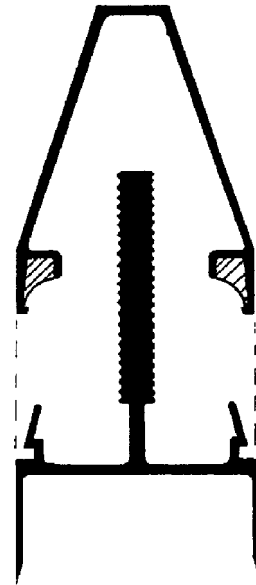

Note that special care must be taken to position carefully and keep perfectly straight until the adhesive has cured.

Suitable adhesive: Tremco Proglaze Silicone.

- 4.5 **Steel flats**: The 17136 inner capping for the 17101 mullion is designed to receive 100mm x 6mm. 8mm or 10mm steel flats on one or both sides of the serrated inner fin.

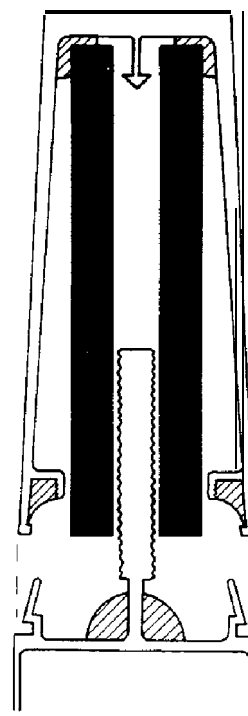

Important:
Both the 17135 and 17136 cappings have a very positive engagement onto mullion 17101 and care must be taken to position correctly even when not 'locked' with adhesive because they are very difficult to remove once fitted.

These steel flats should run for the full length of the mullion concerned, but they can finish just short of any fixing brackets. They should always be used in conjunction with an adhesive lock capping and locally applied silicone and/or packers can be used to retain them in the required position.

Note that special care must be taken to position carefully and keep perfectly straight until any adhesive used has cured.

Suitable adhesive: see para 4.4.

Prior to application the steel flats must be effectively rustproofed.

- 4.6 **Rail brackets:** To avoid loss or misplacement all rail brackets can be pre-fitted to mullions using No. 10 x 1/2" pan hd self-tapping screws. Note that the brackets are applied completely dry because the necessary sealant is applied on site at the time when rails are fitted (paras. 5.9, 13, 14 & 19).

Care must be taken to mount these brackets the correct way up as illustrated on pages 13 and 15.

- 4.7 **Mullion sleeves:** These should be pre-fitted to ensure correct assembly as detailed on page 8 and para 3.6.

- 4.8 **Eaves brackets 312/27:** This bracket has ends cut at 30° so that it can be positioned to suit any roof angle between 15° and 45°. Although each angle condition varies slightly and its position will need to be established by carrying out a practical trial -when correctly positioned the bottom nose of the bracket should make touch contact with the underside of the vertical mullion nose.

Application procedure is first to apply a liberal amount of silicone sealant to the base and a thinner layer to the sides of the sloping mullion, about 50 mm back from the mitred end. The 312/27 bracket should then be fed into the mullion, lifting it over the sealant, and pressed home into its correct position. It is then forced home fully by driving home the two No. 8 csk self tapping clamping screws.

At this point any exposed sealant should be cleaned off and any bulges of sealant internally smoothed off to ensure that they will not increase the barrier to any water flow down the sloping mullion tube.

The preparation for the three No. 10 x 1/2" pan hd self-tapping screws to secure the vertical mullion should now be carried out at their most advantageous position, although assembly should wait until final erection on site to avoid any stress.

Wherever mullions stronger than the basic 17100 are necessary, additional jointing brackets or tie backs are necessary to ensure adequate strength of vertical to sloping mullion attachment.

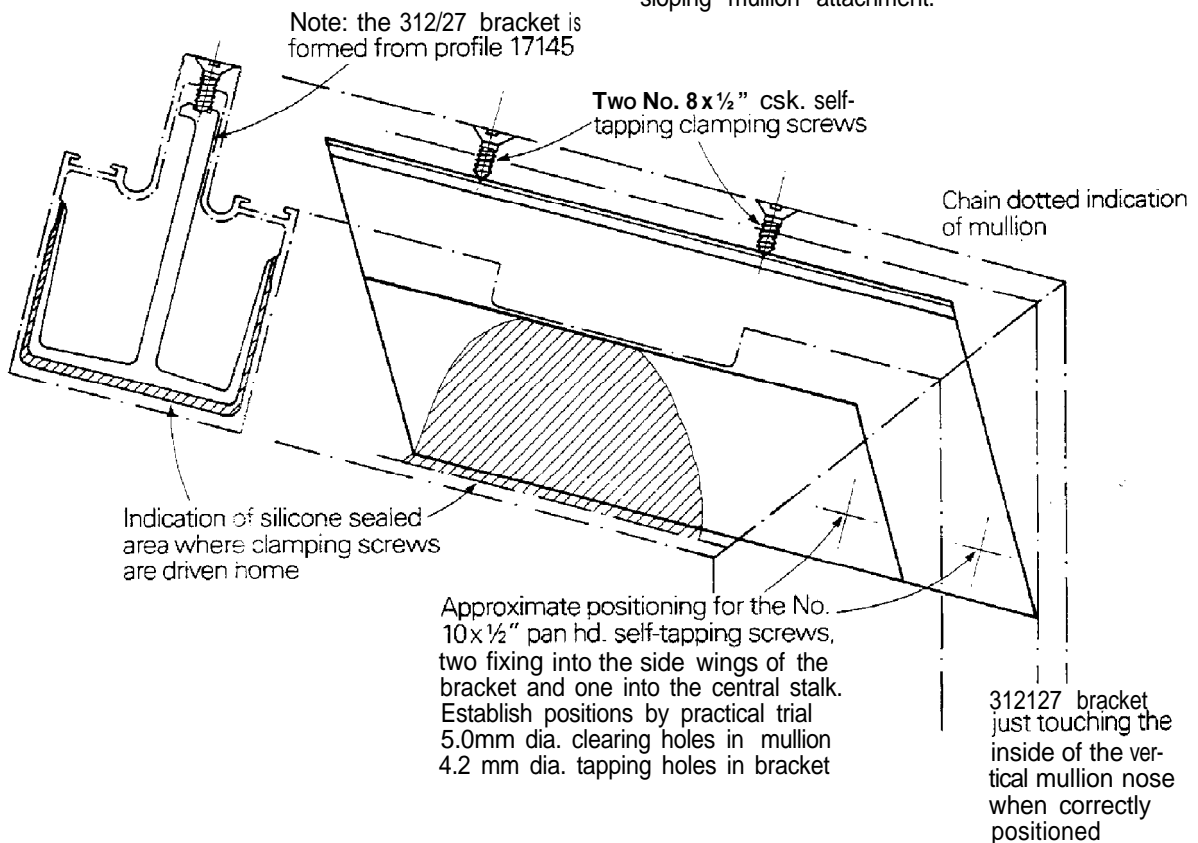

Rails for vertical and sloping glazing

- 4.9 Apart from the preparation for and temporary prefitting of the clamp plates applicable, all other assembly work on these rails must be left until the final fitting on site. This is because the rail to bracket joint must be effectively sealed at that time (paras 5.9, 13, 14 & 19).

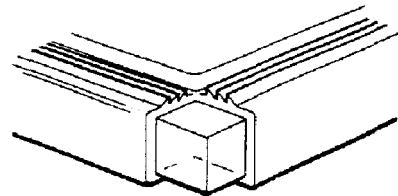

Gasket corner detail

Roof ventilator

(Page 14 and paras 3.67-78)

- 4.10 This unit can be completely preassembled because the finished unit is fitted into the sloping mullion/rail assembly in exactly the same way as the glazing.
- 4.11 **Adaptor frame:** The mitred 17181 profiles are jointed by using drive-in cleats 312129, with sealant to make the joint watertight, and the end screws of the glazing angle positioned to fix through into the cleat and 'lock' the whole assembly (para 4.12).

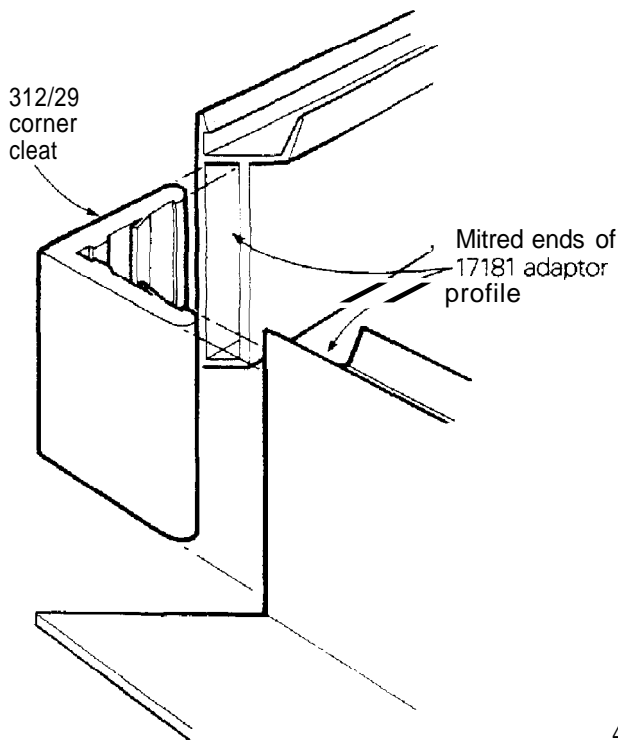

- 4.16 The weatherstrip 105153, should now be carefully fitted to the 17180/T frame members and secured by clamping or adhesive.
- 4.17 The top and bottom 1718017 frame members should now be carefully positioned and driven almost fully home on to the glazing unit.
- 4.18 The side members should now have 312/28, corner cleats gently hammered home until they will enter the corresponding recess in the fitted top and bottom members. Sealant should now be applied to all the contact surfaces and all members gently driven home and adjusted as necessary to form an effective junction.

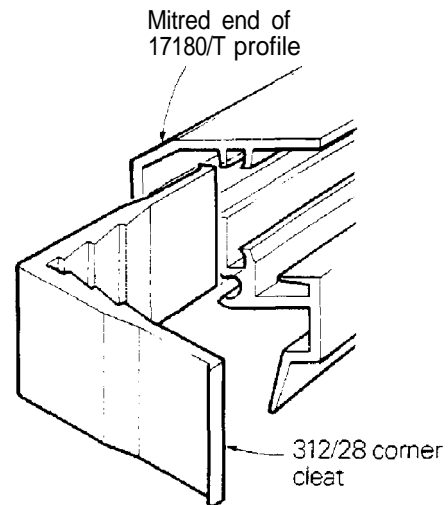

- 4.12 The 17154 liner is now clipped into position and the 2457 glazing angle positioned to match the glazing thickness. Secure with self-tapping screws 60 mm in from the outer corners and at no more than 200mm centres between
- 4.13 A check should be made to ensure that all corners are effectively sealed.
- 4.14 Note; if the 312.29 cleats are too tight to drive in easily the projecting fins can be easily bent inwards in the central area with a hammer, leaving the ends of the fin to engage fully.
- 4.15 **Opening frame:** Prior to assembling the frame the glazing unit should be fitted with the appropriate gasket butt jointed at the top. Care must be taken not to stretch.

- 4.19 The corners should now be secured by driving home the No. 12 x 2" pan hd self-tapping corner screws.
- 4.23 Small spots of sealant should be applied under the glazing (gasket shoulders at the outer corners and the gasket dressed home into the framing as necessary to give an acceptable finish
- 4.21 **Roof vent assembly:** The opening frame should be fitted onto the adaptor frame, making sure that the bottom members, with drainage holes, come together and then the 2457 angle hinge retainer is fitted at the top to secure in place.
- Check that it opens smoothly through 45".
- The bottom should then be secured for safety either with a temporary bracket or by prefitting the operator

Ridge assembly

(Page 15, paras 3.54 3.561)

- 4.22 With this member, only the ridge bracket can be pre-fitted. all other fixing and assembly should be done on site to ensure the correct accommodation of the actual conditions
- 4.23 The ridge bracket is either 312/14, if the roof slope is 15°, or a purposemade item formed from profile 2704 (as para 3.58)

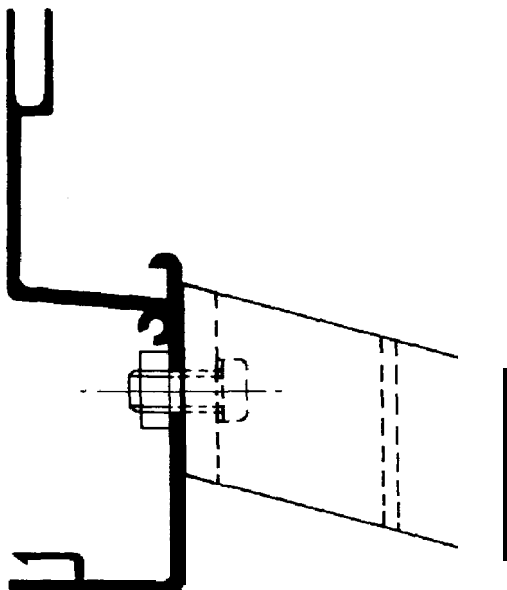

- 4.24 These brackets should be secured in place, bedded on **small** joint sealant, using M8 x 20mm socket hd-set screws and washers fixing through the ridge profile into 2021239 tapping plates.

Note that the tapping plates should be fitted with a smear of sealant so that they will remain in position if the screw is ever removed after the ridge profile is in position.

- 4.25 Because there is no positive location for this assembly, care must **be** taken to fit these brackets dead square and *at* the correct relationship to the 6mm dia bulb, as illustrated under para 3.55

Installation

Sub-d 17120

- 5.1 This should be the first member fitted on any vertical curtain wall with great care being taken to ensure that it is dead level and in its correct position relative to the head and any intermediate conditions.
Fit packers as necessary at each fixing point.
- 5.2 At each fixing point the perimeter of the fixing holes should be buttered with sealant and the 312/13 cill retainer fitted prior to driving home the fixing screws. Any unused holes must be plugged.
- 5.3 A bead of sealant must also be run, unbroken, under the rear of the sub-cill to ensure that no water which may get under the sub-cill can penetrate inwards.

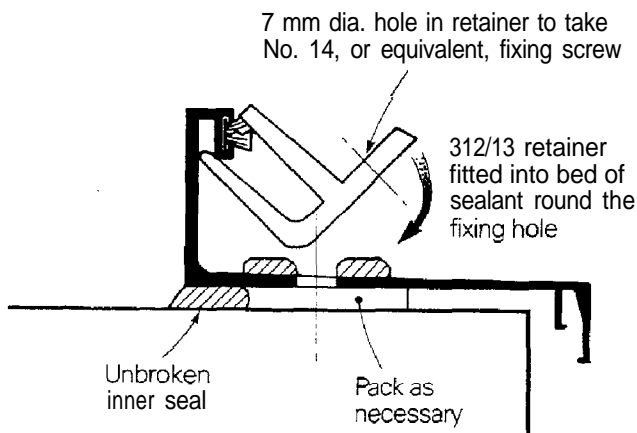

- 5.4 Where the end of a subcill run meets the structure it must be bedded in sealant to ensure that no water on the sub-cill surface can overflow the ends or penetrate the back upstand.
- 5.5 At any intermediate joints, the subcill should be butt joined, metal to metal, and heavy beads of sealant applied about 40 mm either side of the joint. The joint should then be covered by hooking the 312/2 joint cover into the upstand recess and pressing it firmly home into the sealant to form a completely watertight barrier

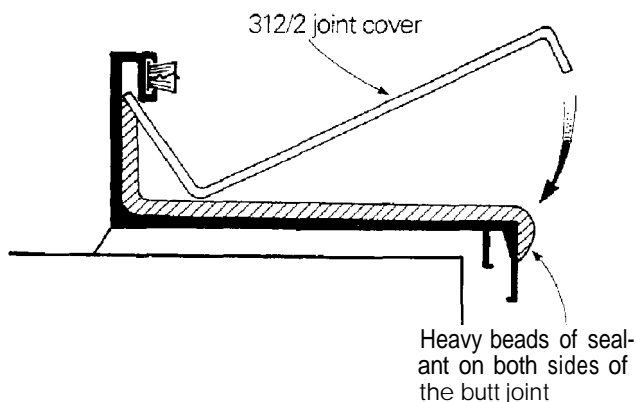

- 5.6 When completed the whole run of sub-cill should be rechecked to ensure that it is dead level and in the correct position, and that there are no weak spots in the sealing which could allow any water penetration from the top surface or under the sub-cill

Mullions in vertical glazing

- 5.7 Starting from one end the first mullion should be fitted over the cill retainer and secured at its head. If the fixing is as illustrated on page 8, the central slotted holes will allow for the initial positioning (the drilling for the other two fixing bolts should only be done when correct positioning of the total assembly has been verified). Note that for 'hung' construction the back end of the mullion should be 8mm above the subcill surface, as illustrated, but should sit solidly onto the retainer for any 'prop' condition.

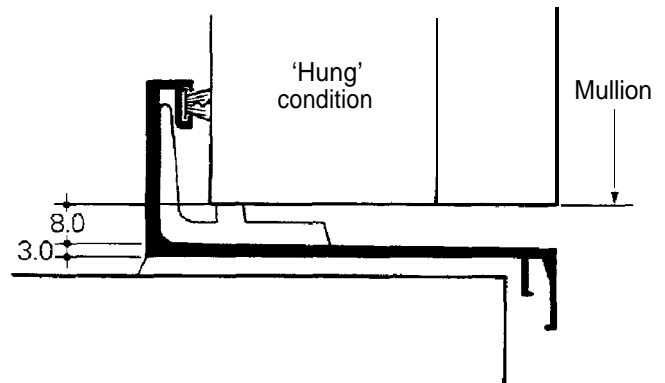

- 5.8 The next mullion along should now be fitted in the same manner, using the bottom rail, or a prepared staff, to ensure correct spacing.
- 5.9 Sealant should now be applied to the bottom rail brackets, as illustrated, and the bottom rail should be fitted onto them, with its inner leg engaging into the cill retainers, and then be secured by No. 8 x 3/4" pan hd self-tapping screws fixing into the bracket screw splines.

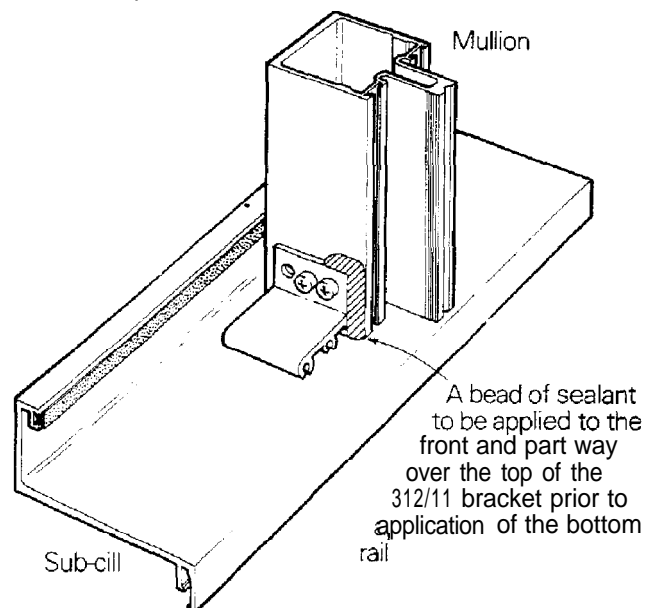

- 5.10 This procedure should be repeated until all the lower mullions and bottom rails have been fitted
- 5.11 On multi height units the next stage will be to fit the next run of mullions above and a similar procedure should be followed, the only variation being the sleeved joint. This requires the projecting sleeve of the upper mullion to be inset-ted into the lower mullion
For 'hung' construction a 5mm temporary spacer should be fitted to ensure that the necessary expansion gap is maintained, but if the mullion above is in a 'prop' condition no gap should be allowed.

Ensure that ends are sealed at these points

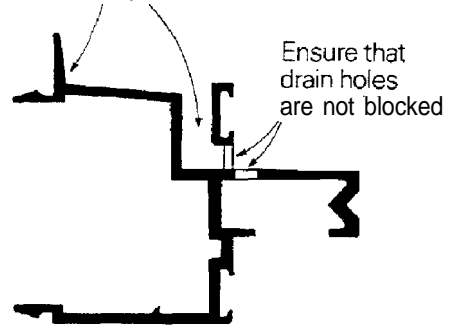

Rails in vertical glazing

- 5.12 Once the mullions are in place and have been accurately positioned the rails can be fitted to complete the main framework.
- 5.13 For the normal 17110, and narrow 17113 rails the procedure is similar to the bottom rail except that the sealant runs at the front of the bracket with small returns at top and bottom. and that the rail is applied from the front.

Ridge 17162

- 5.15 Correct positioning for this member can best be established by fitting the mullions to it at each end, supporting as necessary to avoid stress, so that the precise practical position can be established.
- 5.76 Once positioned correctly the fixing screws can be driven home taking care to ensure that there is no sag between supports. Note that the ridge member, either single or double, is fitted dry at this stage.

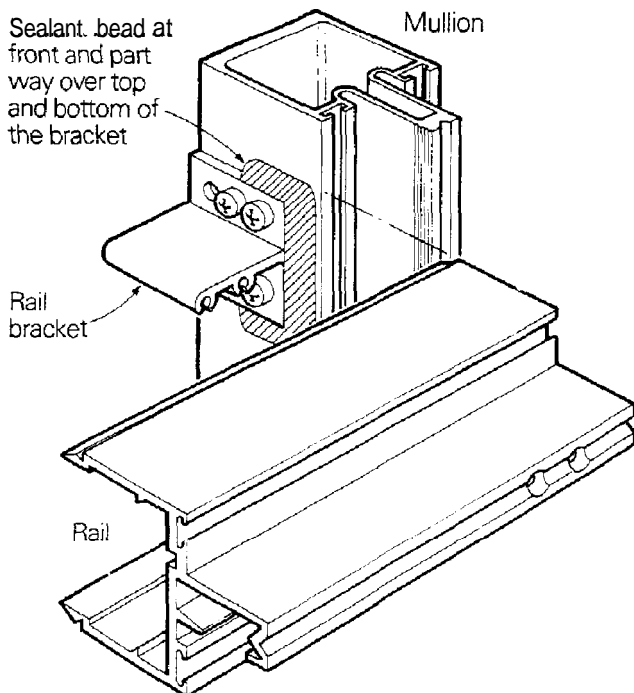

Mullions in sloping glazing

- 5.17 Where these fix to the 17162 ridge member (page 15) a bead of sealant must be applied round the whole perimeter of the ridge bracket.
The mullion can then be fitted tightly home into place and 4.2 mm dia. holes drilled into the bracket, using the clearing holes in the mullion as a guide, and the No. 10 x ½" pan hd self-tapping screws can be driven home to secure.
Important: a check must now be made to ensure that the drainage holes are clear and that any obstruction is removed.
- 5.18 Where these fix to a mitred eaves detail (pages 16 & 17) small joint sealant should be applied to the mullion contact surfaces, the mullions should be brought together and the three No. 10 x ½" pan hd self-tapping screws driven home to secure.

- 5.14 For the drained rail 17111 the procedure is the same but with additional sealant being necessary to seal the ends of the inner upstand and the drainer channel. Also a check should be made to ensure that the drain holes are not blocked.

Roof rail 17160

- 5.19 In a similar manner to the rails in vertical glazing, a bead of sealant should be applied to the top and part way down the sides of the 312425 bracket, when in position, and the rail should be fitted over. Secure in place by driving home the No. 8 x 3/4" pan hd self-tapping screws into the screw splines of the bracket.

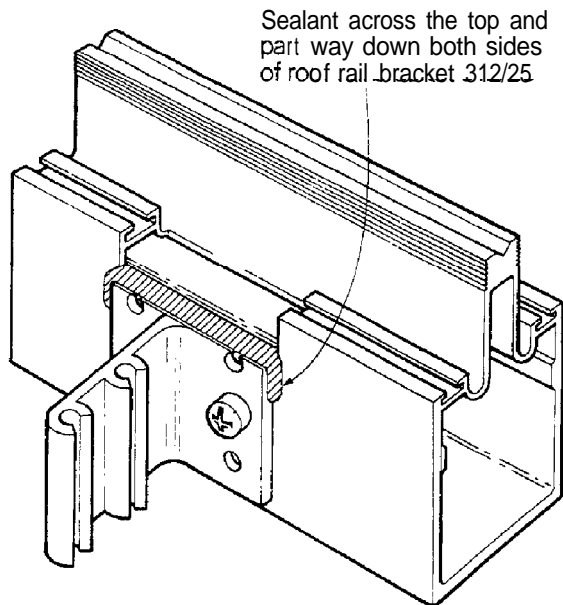

- 5.20 Remove any surplus sealant and ensure that there is no obstruction to drainage from the rail into the mullion tube.

Preparation for glazing

- 5.20 When the basic framework of mullions, rails, etc., has been correctly positioned and secured, the fitting of glass, panels and opening light inserts can proceed.

The inside seal is of vital importance and this should be fitted first. This will be either 1051131 or 132 EPDM sponge seal to suit the glazing unit thickness.

- 5.22 The inner seal should run through unbroken for the full length of the vertical and/or sloping mullions. Any joints necessary should be either at roof rail recesses, in sloping glazing, or at the centre of rails in vertical glazing.

On the rails the gaskets should be cut slightly longer than the rail length (approx 1%) and should then be fitted so that they butt against the mullion gaskets under slight compression.

Immediately prior to any glazing unit being fitted the ends of the rail gaskets should be lifted and a small amount of butyl sealant applied so that, when the gasket is repositioned the joint will be completely

sealed -this is particularly important at the ends of the lower gasket on any rail (top of glazing unit) as illustrated.

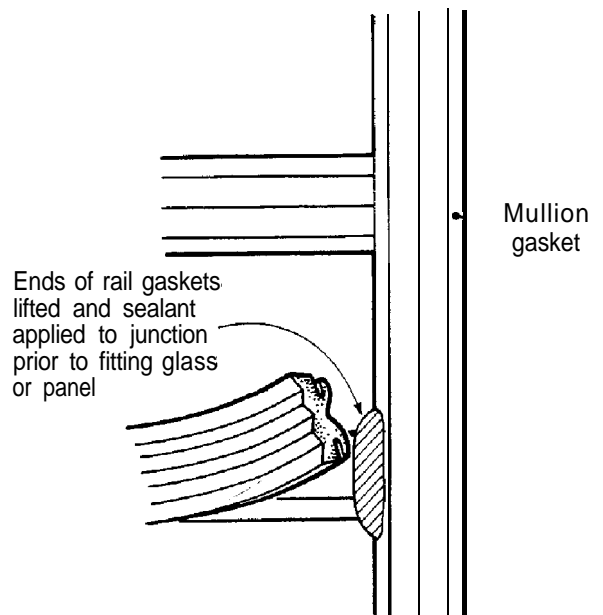

- 5.23 One variation to the inner gasket which we would advise is on any pane where opening light inserts are to be fitted. Where these have an inner leg which must pass over the gasket they tend to snag the gasket at some point while being fitted.

To help avoid this problem the shoulder of the gasket at the bottom should be trimmed off. This will allow the insert to be offered into one side first, then by resting it on the inner leg at the bottom corner, there should be sufficient clearance at the top and opposite side of it to pivot into place without fouling the gasket

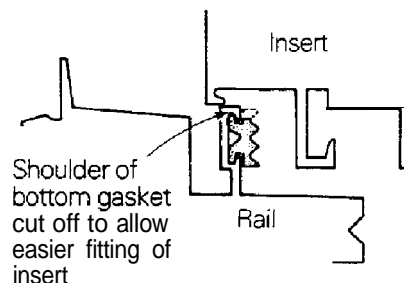

Glazing

- 5.24 If the clamp plates have been pre-fitted to the mullions and rails they should be removed, taking care to identify which members they come from to ensure correct re-fitting.
- 5.25 Prior to fitting the glazing units into place on vertical glazing, a bead of silicone should be run across the rail at the top, between the EPDM gasket and the rail projection, so that the unit will bury into it when fitted.

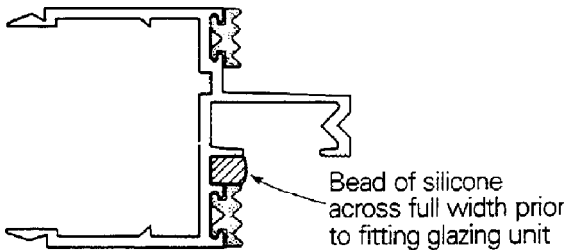

- 5.26 5 mm thick setting blocks should be positioned on the rail at the bottom, no more than 50mm from the rail ends.
- Note that it will be necessary, on vertical glazing, to cut back the top flange of the clamp plate spacer to fit round these blocks. Pincers are ideal for this purpose.

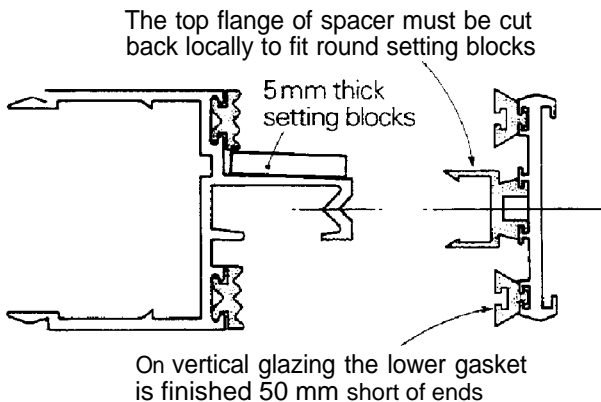

- 5.27 Important Note: The lower outer gasket on all rails in vertical glazing must be finished about 50mm short of each end to provide for essential cavity ventilation and drainage, as illustrated above. The remaining outer gaskets (upper on vertical glazing rails and both on roof rails) are fitted for the full width with a slight overhang to ensure a tight fit against the mullion gaskets.
- 5.28 At the edge detail (page 15) the 105/141 inner seal should be cut slightly oversize (approx 1%) for fitting dry onto the bulb of the ridge upstand between each mullion. Its shape allows it to adapt to any glazing slope between 15° and 45°.
- 5.29 The glazing units can now be fitted into place and secured at the rails either temporarily with clamp plate off-cuts or with the correct members.

- 5.30 The mullion clamp plates are fitted last because they should run for the full mullion length so that they contribute maximum strength to the total mullion assembly.

Application of mullion and rail cappings

- 5.31 The inside cappings on rails (page 13) can be applied in any exposed areas once the end fixing and sealing conditions have been checked.

The outer mullion cappings should then be fitted with a local (approx. 100mm) application of silicone on the contact surfaces near the centre of any length so that it will allow for thermal movement but will resist any tendency for the capping to creep downwards. Any expansion gaps between cappings (para 3.39) should be sealed off flush with silicone.

- 5.33 Outer rail cappings should now be fitted but just prior to their being clipped into position the junction between the top rail gasket and the mullion gasket should be bedded in sealant and a bead of sealant run down the small gap between the rail clamp plate and the mullion capping, as illustrated below. This is to discourage water penetration at this point.

After fitting the rail cappings any surplus sealant should be cleaned off.

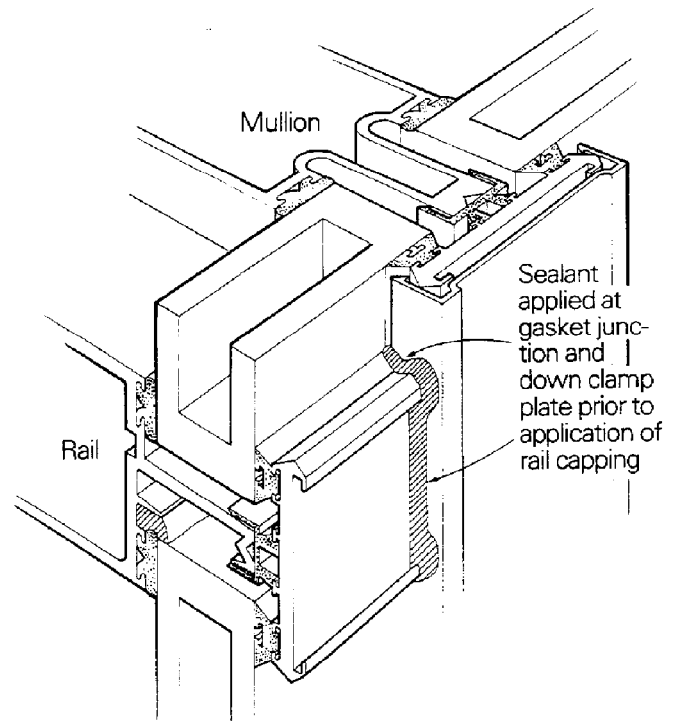

Application of roof rail capping 17161

- 5.24 This member is fitted with 1051136 gaskets arranged so that they will fit effectively against the mullion gaskets at each end.

- 5.35 An unbroken bead of sealant should be applied on the underside alongside the upper gasket just prior to fitting.

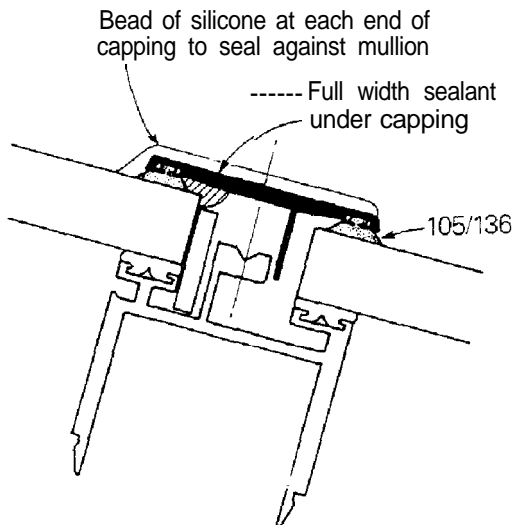

- 5.36 The capping should be carefully positioned and the No. 8 csk self-tapping screws driven home into the rail to secure.
- 5.37 A thin bead of silicone should now be applied at the end junctions with the mullions to discourage water penetration at these points.

Application of ridge capping

- 5.38 Capping profile 17163 should have the 105/143 ridge flashing cut into slightly oversize (approx. 1%) lengths to fit between the mullion cappings and these should be fed into position

The full length 105/142 insulation gasket should then be fitted and the complete assembly entered a short way into the upper ridge recess.

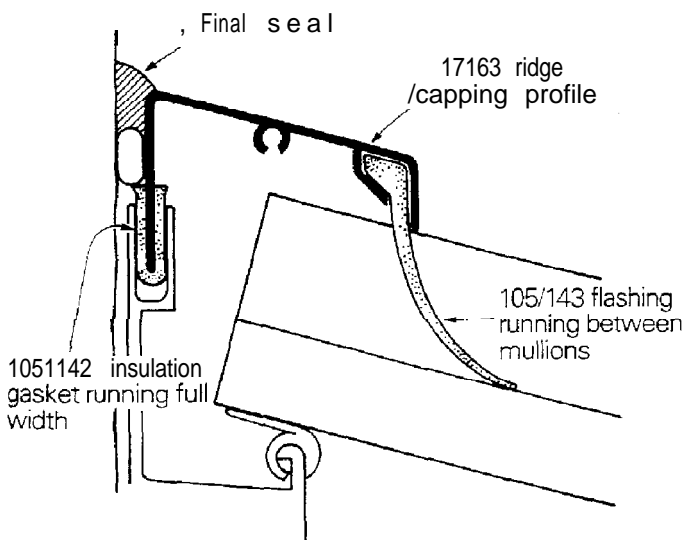

After adjusting the ridge flashings to their correct positions the capping should be pushed fully home until the front downstand makes contact with the top surface of the mullion capping.

The upper final bead of sealant should now be applied.

- 5.39 Where appropriate the ridge stop end 312122 can now be fitted to close off the extreme ends.

These are prepared with only one 4.5 dia. hole to pick up on the ridge screw spline. The remaining hole to link through with the capping screw spline has been left for site drilling to cater for detail variations.

No. 8 x 3/4" pan hd self-tapping screws should be used to secure.

Application of gutter 17171

- 5.40 This profile is arranged so that it will engage into the rail clamp plate and the mullion clamp plates and cappings should be finished short to allow it to run through.

- 5.41 The application of wedge gasket 105188 is used to seal and lock the whole assembly for its full length.

Note: screws can be driven through the inner upstand into the nose of mullions if additional fixing is required.

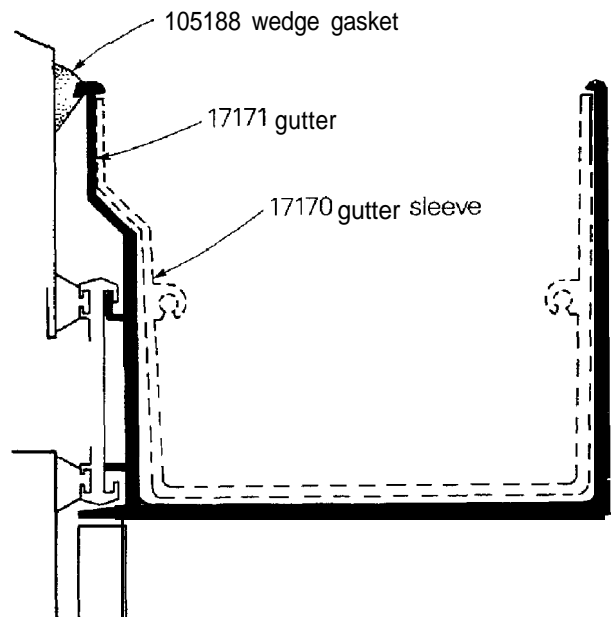

- 5.42 Any straight gutter joints are made watertight by applying a heavy bead of sealant to the bottom and sides about 40mm either side of the joint and then pressing home a 150mm length of 17170 sleeve profile until its upstands clip under the gutter shoulders.

Angled joints are formed in a similar manner (see para 3.65).

- 5.43 A similar application of the 17170 sleeve profile at the ends of any run of guttering will allow for the fitting of 312123 stop ends which should be screwed into place against a bead of sealant using No. 8 x 3/4" pan hd. Self tapping screws fixing into the sleeve screw splines.

(See section 6 for downpipe notes).

Gutter outlets and downpipes

6.1 A large range of types are available from various suppliers so we have not included these items in our range, but we have given below details of one typical range which can be obtained from

Alifabs (Products) Ltd., Forsyth Rd., Sheerwater, Woking, Surrey GU21 5SB (0483 755744).

6.2 This company can supply 100mm long sleeves to suit either their 76mm x 76mm or 76mm x 102mm downpipe and these can be either cleated or welded to our gutter profile 17171 as indicated in para. 3.66.

On any downpipe order to Alifab this item should be specified as:

Pipe joint spigot to link with Glostal guttering.

6.3 The downpipes are available from Alifabs in straight lengths of 2000mm or 4000mm, together with off set bends and shoes
Finishes are either mill or powder coated to any required standard colour.

6.4 Twist-in type fixing brackets are also available which allow positioning at any curtain wall rail point.

The only modification necessary to the bracket is the countersinking of the fixing holes so that the screw heads will not protrude. This allows the rail capping completely to conceal the base plate of the fixing bracket. If positioned at a mullion centre it will be necessary to cut away the side projections of the mullion clamp plate to allow for the bracket.

