

Sapa's policy is one of continual system development and we reserve the right to incorporate design improvements and changes. □
 Every effort is made to ensure that all details are correct at time of publication. However, it is the responsibility of the customer to □
 check the accuracy of the relevant facts and information before entering into any contract or other commitment. Up to date □
 information is freely available from the Sapa Building Systems Webshop. □
 All Products and systems which Sapa supply are supplied subject to Sapa's standard Terms and Conditions of Sale current from □
 time to time.

Index

	<u>August 2002</u>	<u>Page</u>	<u>Last Issue</u>	
Specification	Scope, Performance & Size Limitations.	1-1	01.99	
General Arrangements	Centre Pivot Doors.	2-1 - 2-2	01.99	
	Rebate Open In Doors.	2-3 - 2-4	04.00	
	Rebate Open Out Doors.	2-5 - 2-6	04.00	
	Centre Pivot Doors with Anti Finger Trap Stile.	2-7	04.00	
	Rebate Open In Doors with Head Closer.	2-8	04.00	
	Rebate Open Out Doors with Head Closer.	2-9	08.01	
	Bottom Rail Adaptor & Muntin Bar.	2-10	08.01	
Parts List	Profiles.	3-1	08.01	
	Door Kits & Components.	3-2	08.01	
	Components.	3-3	08.01	
	Components, Weatherseal & Screws.	3-4	08.02	
	Tooling & Drill Sizes.	3-5	04.00	
	Full Size Profile Illustrations.	3-6	04.00	
	Full Size Profile Illustrations.	3-7 - 3-8	01.99	
Machining Details	Metal & Glass Sizes.	4-2 - 4-3	08.01	
	Lock Stile & Clip Cover.	4-4	08.01	
	Slave Stile, Clip Cover & Rebate Adaptor.	4-5	01.99	
	Hang Stile & Clip Cover.	4-6	01.99	
	Hang Stile Additional, Anti finger Trap & Hinges.	4-7	08.01	
	Top & Bottom Rail.	4-8	08.01	
	Top & Bottom Rail & Hang Stile Additional, Over Head Closer Into Rebated Doors.	4-9	01.99	
	Weather Bar & Mid Rail.	4-10	01.99	
	Bottom Rail Adaptor.	4-11	08.01	
	Pad Handle Fixing.	4-12	08.01	
	Door Tube Handle Fixing.	4-13	01.99	
	Special Machining for Adams Rite Exit Device.	4-14	01.99	
	" " " "	4-15	04.01	
	Muntin Bar.	4-16	04.01	
	Outer Frame	Rebate Adaptor	4-17	04.01
		Head/Transom for Centre Pivot & Rebate Doors.	4-18	04.01
Head/Transom for Rebate Doors.		4-19	08.01	
Hanging & Locking Jamb for Centre Pivot.		4-20	08.02	
Hanging & Locking Jamb for Rebate Doors.		4-21	08.01	
Centre Pivot Doors Anti Finger Trap Liner.		4-22	08.01	
Threshold for Centre Pivot Doors.		4-23	01.99	
Threshold for Rebate Doors.		4-24	01.99	
Assembly Details	Door Leaf.	5-1 - 5-2	04.00	
	Door Leaf.	5-3 - 5-6	01.99	
	Door Leaf.	5-7- 5-8	04.01	
	Exit Devices.	5-9	01.99	
	Outer Frame.	5-10	08.02	
	Outer Frame.	5-11	04.00	
	Outer Frame.	5-12	08.02	
	Outer Frame.	5-13	01.99	
	Guide to Threshold Grill Assemblies.	5-14 - 5-18	01.99	
Glazing Details	General.	6-1- 6-2	01.99	
	General.	7-1 - 7-2	01.99	
Installation	General.	7-3	04.00	

THIS PAGE INTENTIONALLY LEFT BLANK

Specification

Scope

This specification details materials, construction, finishes hardware and sizes for the Glostal 202 High Performance Door. The system described in this specification and illustrated on the following pages are suitable for installation into new building work or as replacement in existing buildings, being designed for fitting into curtain wall or direct into masonry.

Materials

Aluminium profiles are extruded aluminium alloy 6060 or 6063-T5 or T6 complying with the recommendations of BS 1474 with a minimum thickness of 2.5mm on all main elements of doors and framing.

Polyester powder coated finishes are available to BS 6496 in a wide range of colours. Anodised finishes are to BS 3987 Grade AA25, etch silver and Glostal bronze as standard, with a range of special anodised finishes on application.

Weather sealing is either polypropylene backed woven pile or extruded synthetic rubber held in undercut grooves extruded in the aluminium profiles.

Construction

Framing profiles are square cut for jointing with self-tapping screws fixing into screw splines extruded in the aluminium profiles.

Door leaf profiles are mitre cut at 45° and assembled using specially prepared corner cleats, which clamp the door leaf corners together without the use of any additional tooling.

Hardware

The standard fittings provided for these doors are: -

Dorma RTS 85 concealed overhead door closers (10mm extended spindle and end load only), pivots for swing doors, and Mila pivot hinges for hinged doors.

Adams Rite MS 2200 security lock with hook bolt and European standard profiled cylinders plus Adams Rite 4022 threshold bolt.

Specially adapted Adams Rite emergency exit gear with panic bar or push handles.

Armour strike on double doors and flushbolts.

Aluminium tubular pull handles and pad handles.

Variations by way of special handles, pivot hinges, master key systems, emergency exit devices, automatic door operation, electronic security, etc. can be incorporated into the system as required.

Assembly & Installation

Detailed instructions are provided in this publication, which must be strictly conformed to.

Glazing

Glass must conform to the requirements of BS 6262 for thickness and type. Glass is set dry against synthetic rubber gaskets. Glass is supported on adjustable setting blocks.

Glazing beads and gaskets will accommodate glass and/or panels of 6mm, 10mm and 24mm nominal thickness.

Glazing is into fixed external rebates and internally beaded.

Size Limitations

Door leaf maximum sizes will be determined by a combination of site exposure conditions and hardware specification.

For rebated doors, the overall leaf weight should not exceed 120 kg for a two-hinge installation. For centre pivot doors, suitable strengths closers must be fitted according to the width and area of the door leaf. Minimum door width is 910mm for Adams Rite exit device when panic bar is fitted.

Maximum tested size for pivot and rebate doors leaves are 2137mm high x 1103mm wide, the maximum size can be exceeded under certain circumstances and Glostal's technical department can supply further information on request.

Performance

All product configurations listed in this manual, within the specified size limits, and when manufactured, installed and glazed strictly to the enclosed details, will perform as specified below to BS 6375, Part 1, 1989, and will achieve a Class A for mechanical testing to BS 6375, Part 2.

	Air Permeability	Water Tightness	Wind Resistance
Single/Double pivot doors	300Pa	300Pa	1200Pa
Single/Double rebate open in doors	200Pa	200Pa	1200Pa
Single/Double rebate open out doors	600Pa	600Pa	2000Pa

Note above figures are for doors fitted with standard hardware and that performance figures may change with different hardware, e.g. exit device etc.

THIS PAGE INTENTIONALLY LEFT BLANK

General Arrangement

High Performance Door

Centre Pivot Doors

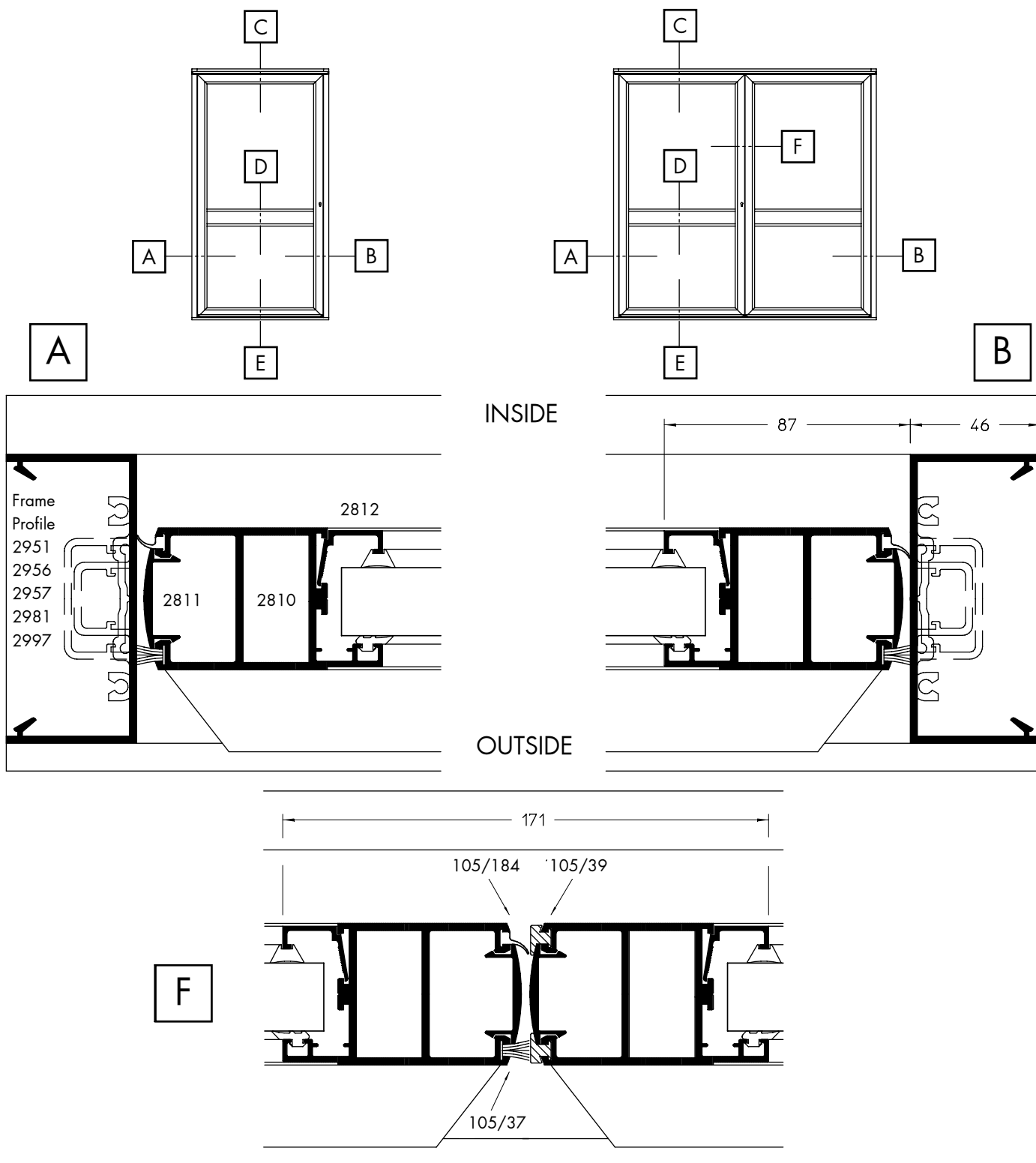

General Arrangement

Centre Pivot Doors

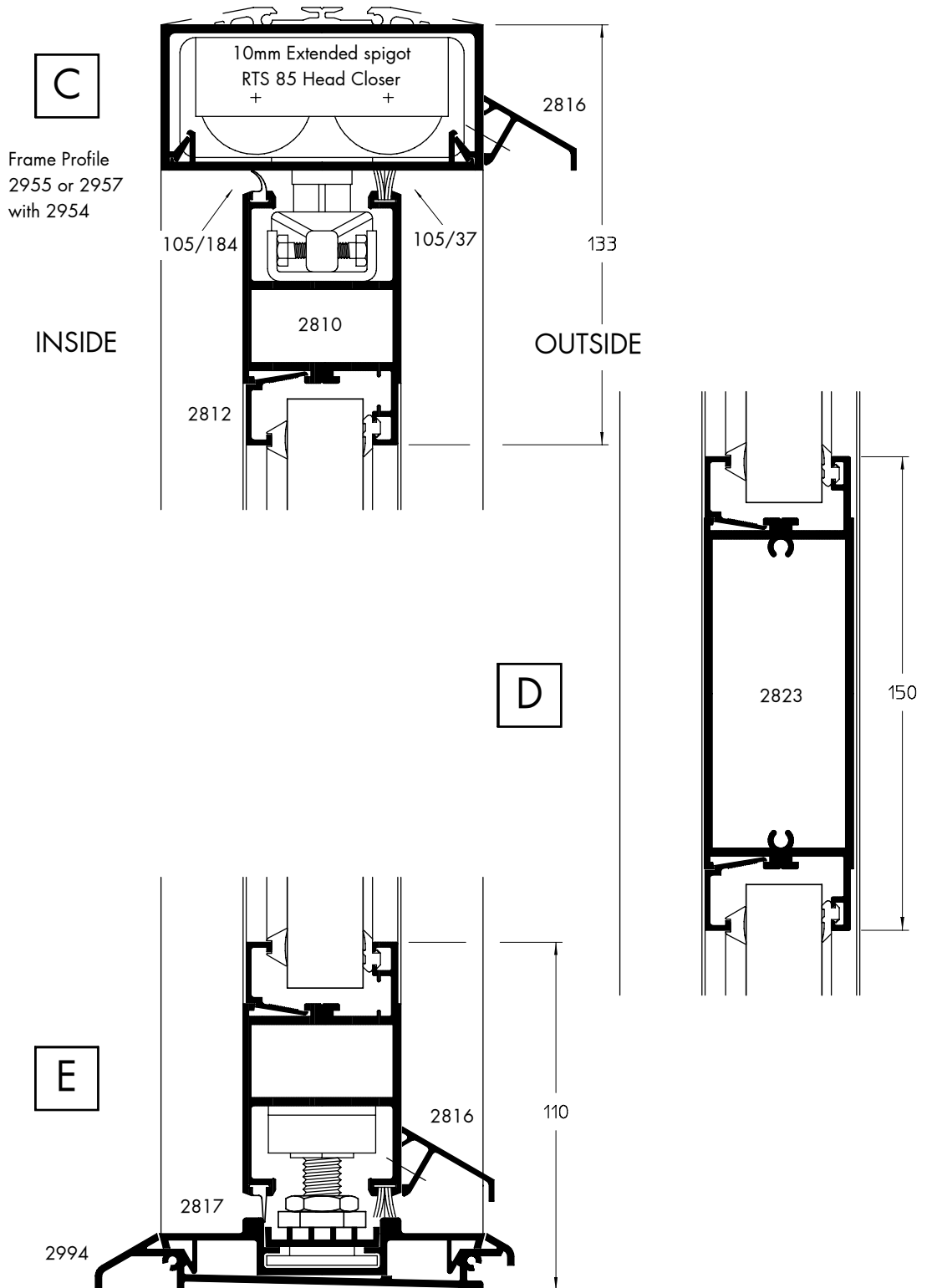

General Arrangement

High Performance Door

Rebate Open In Doors

* = Section opposite hand to that detailed

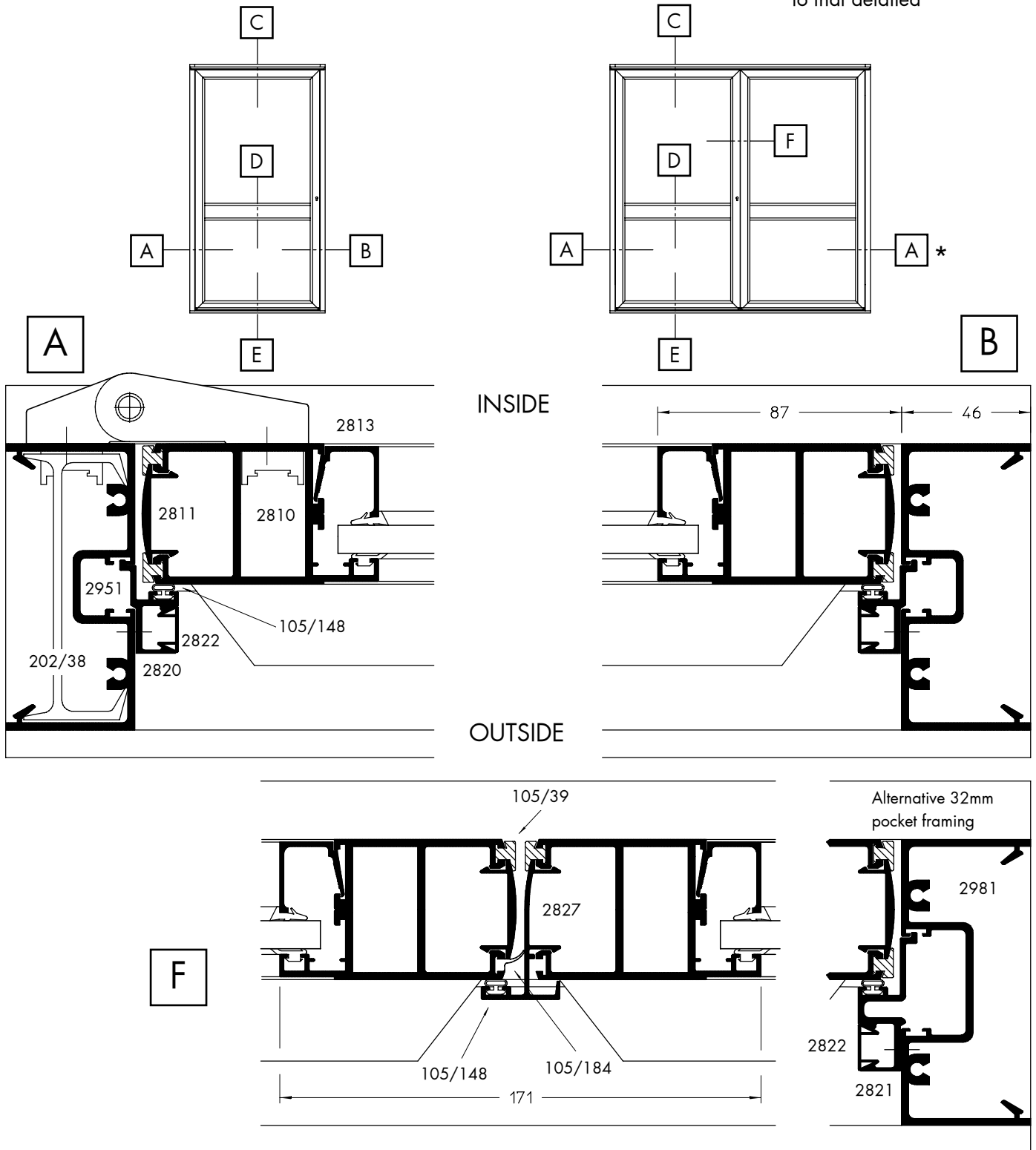

General Arrangement

High Performance Door

Rebate Open In Doors

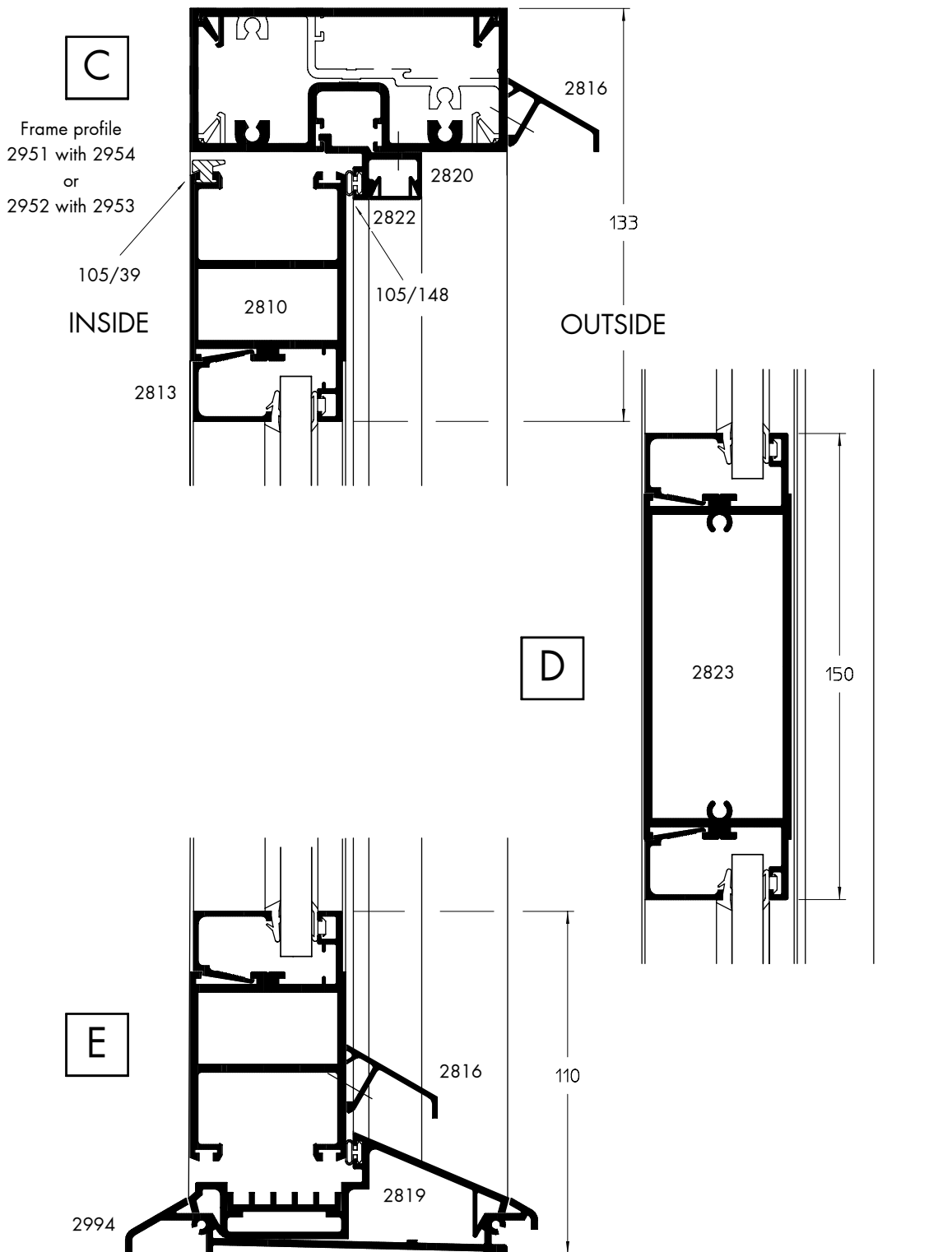

General Arrangement

High Performance Door

Rebate Open Out Doors

* = Section opposite hand to that detailed

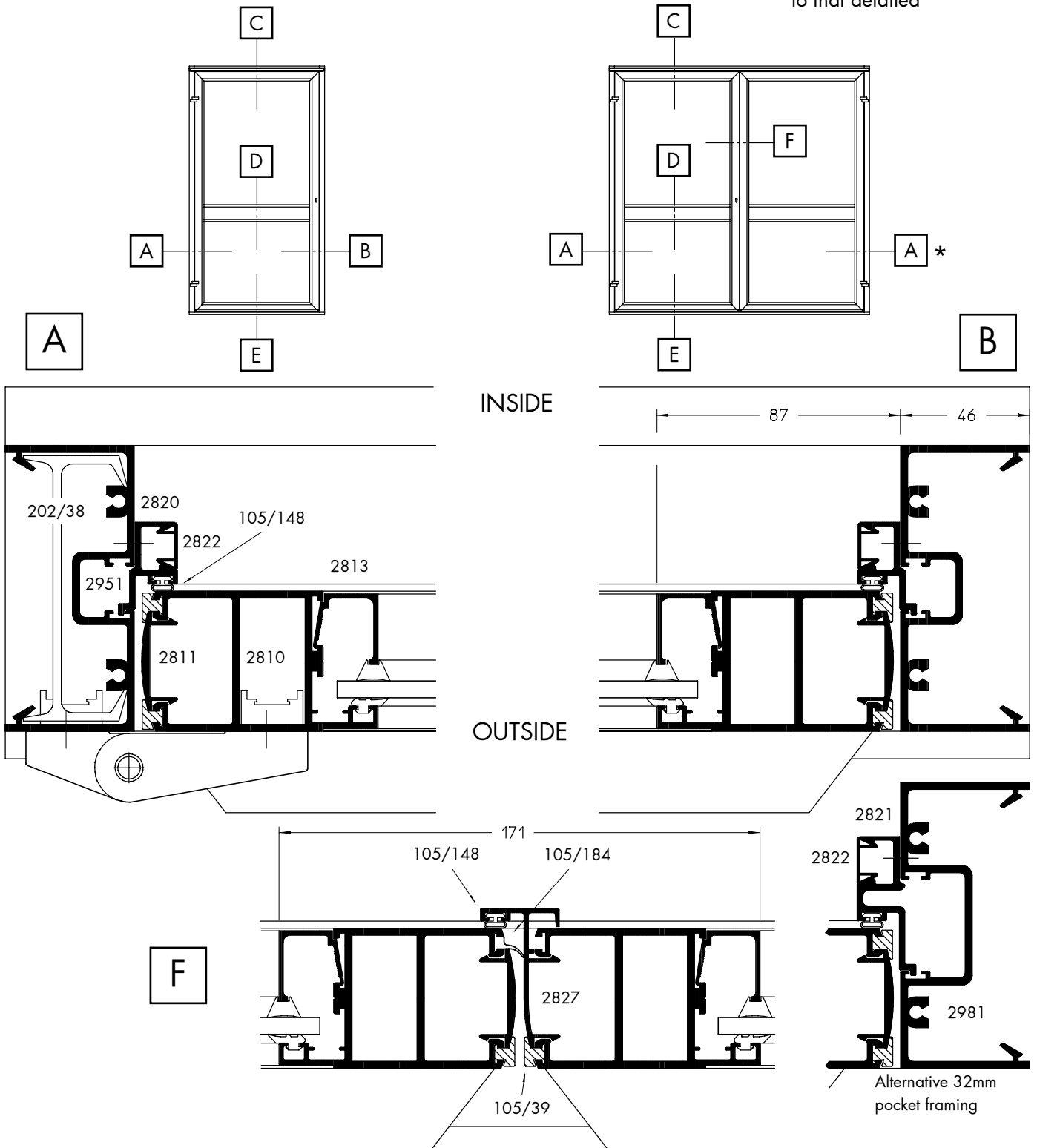

General Arrangement

High Performance Door

Rebate Open Out Doors

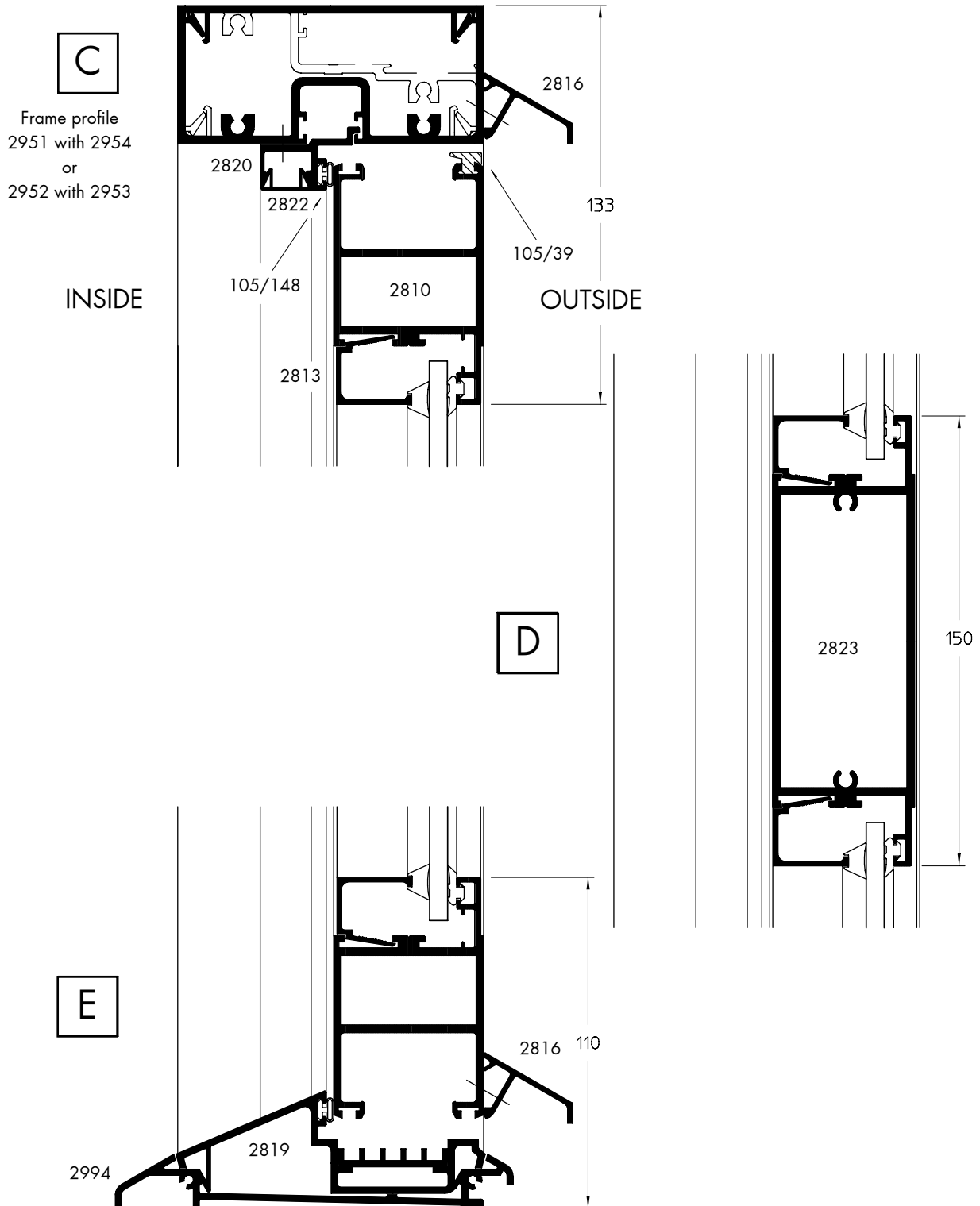



General Arrangement

Centre Pivot Doors with Anti Finger Trap Stile

* = Section opposite hand to that detailed

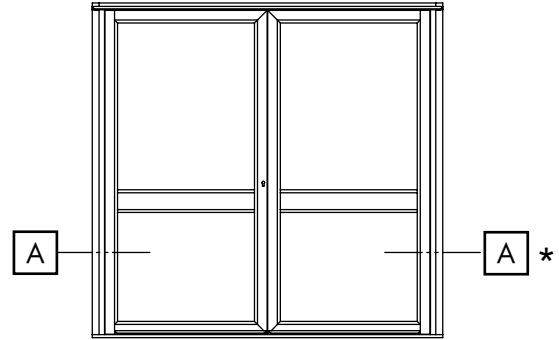
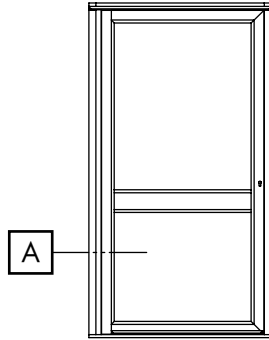

A

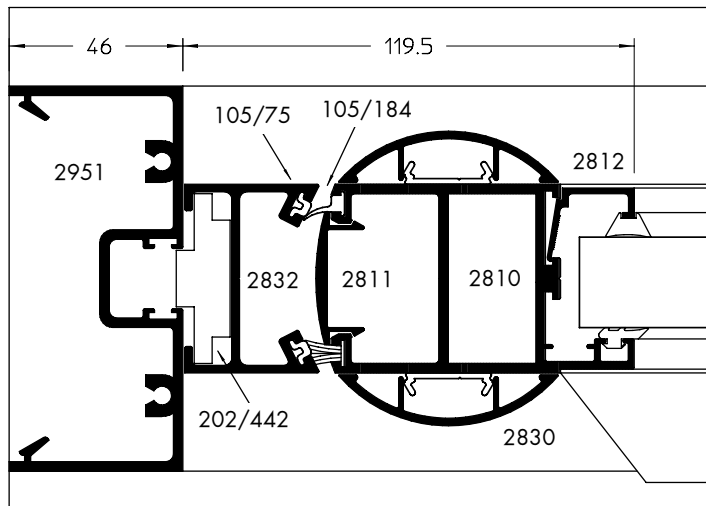

INSIDE

OUTSIDE

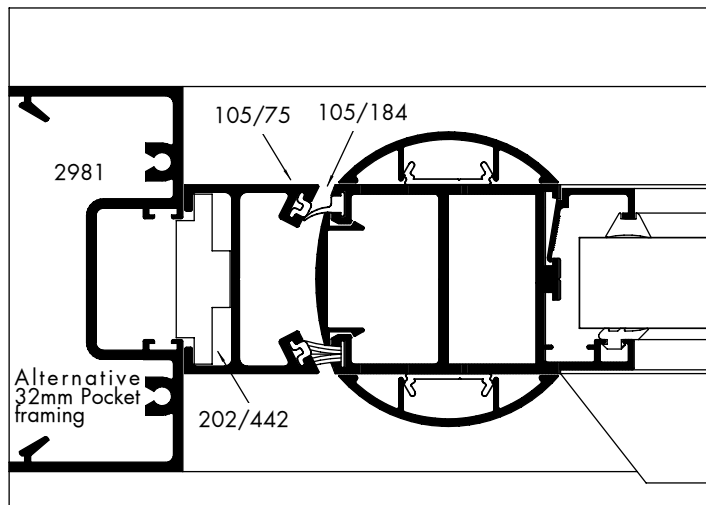

INSIDE

OUTSIDE

General Arrangement

High Performance Door

Rebate Open In Doors with Head Closer

* = Section opposite hand to that detailed

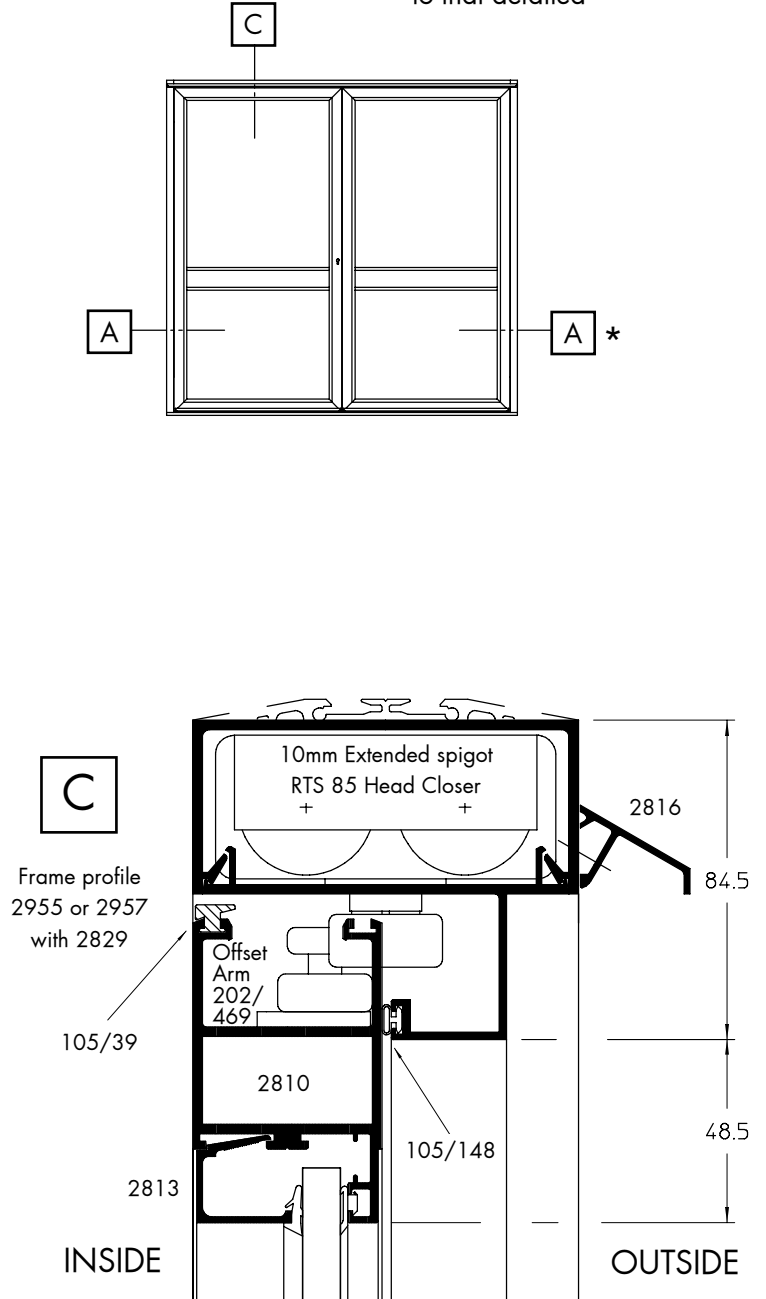
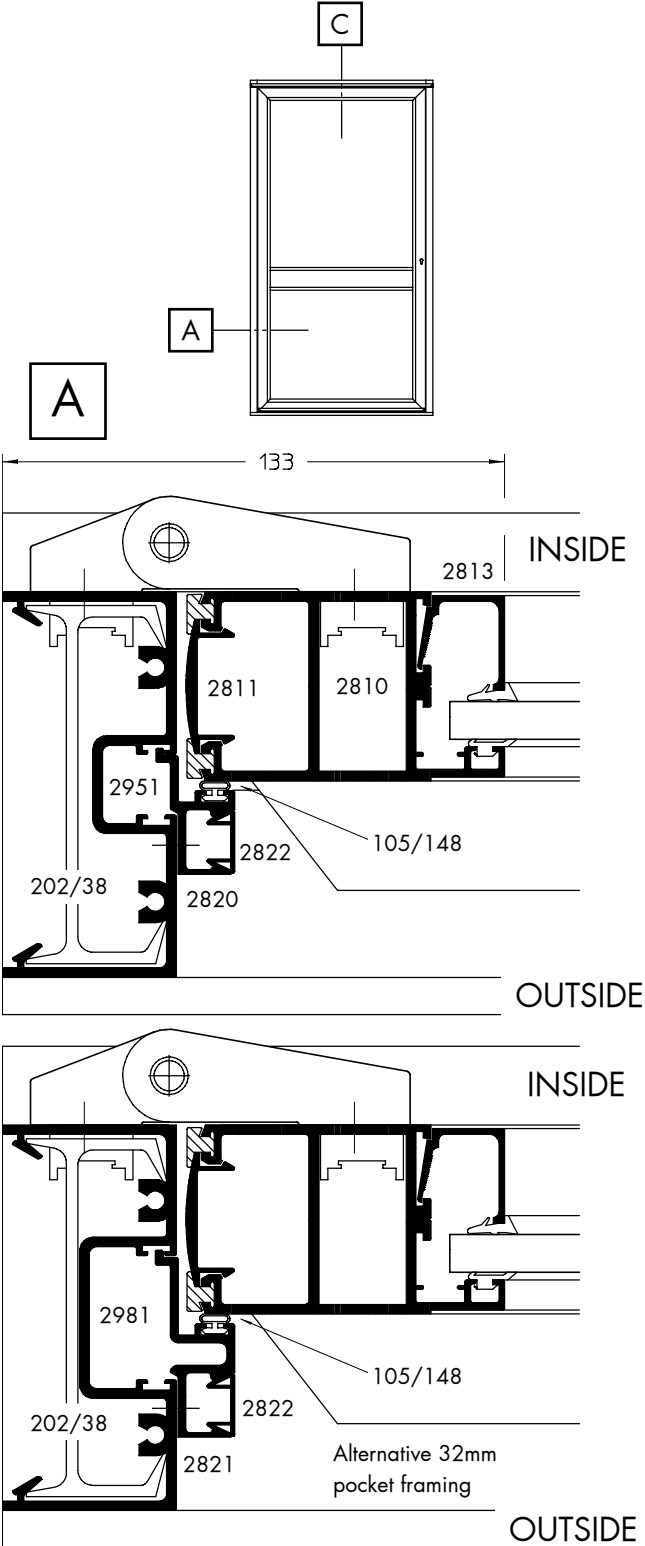

General Arrangement

Rebate Open Out Doors with Head Closer

* = Section opposite hand to that detailed

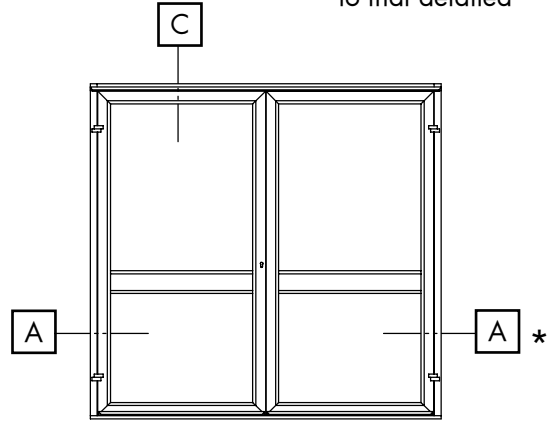
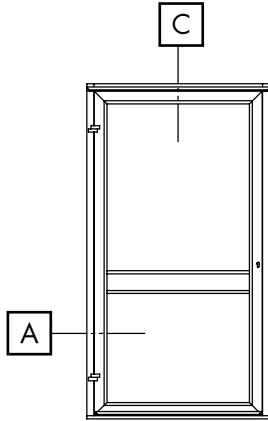

A

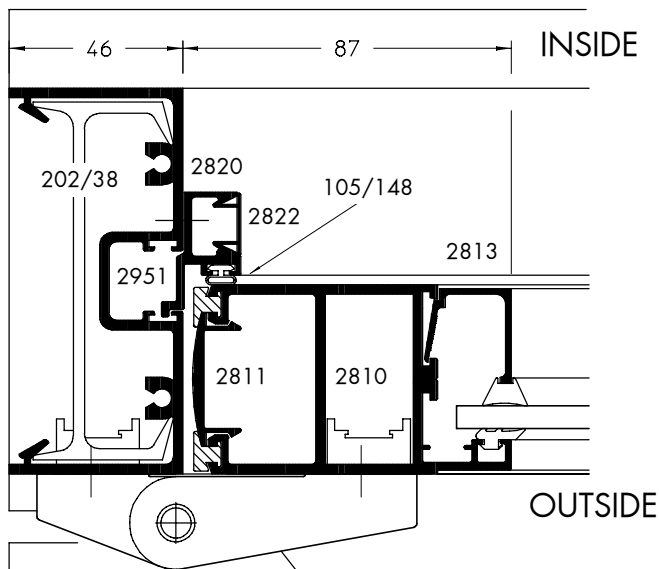

C

Frame profile 2955 or 2957 with 2829

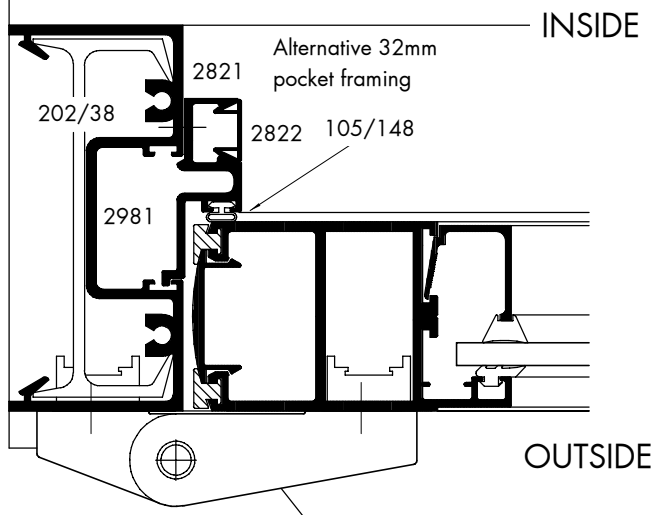
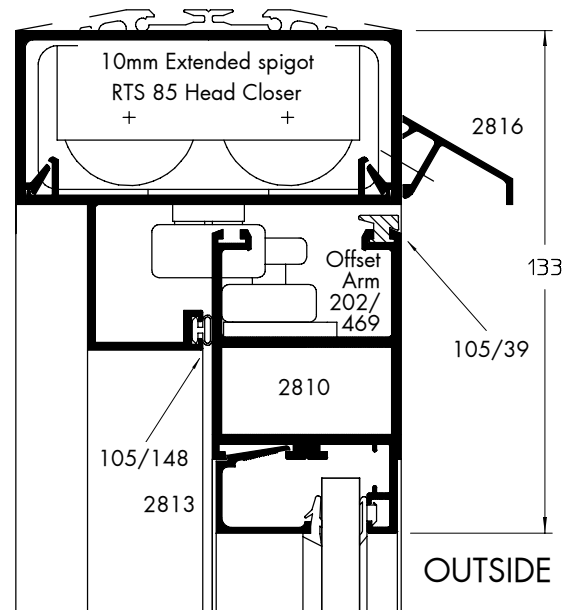

General Arrangement

160mm Bottom rail adaptor
Lightweight muntin bar (24mm glazing only)

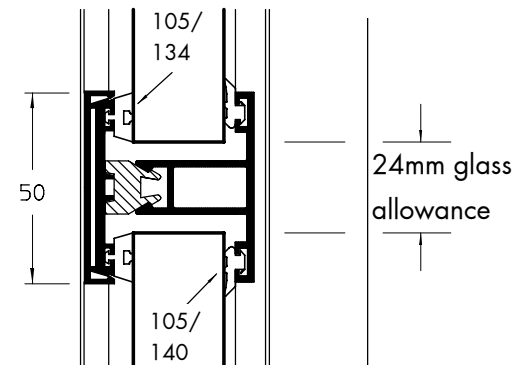
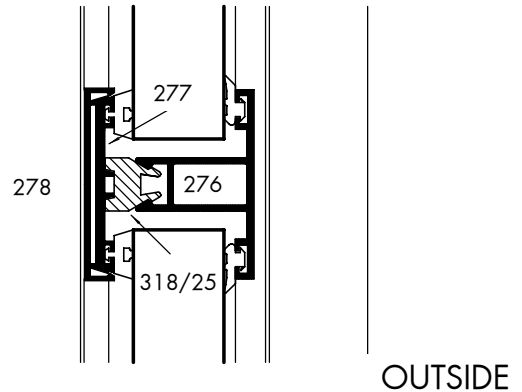
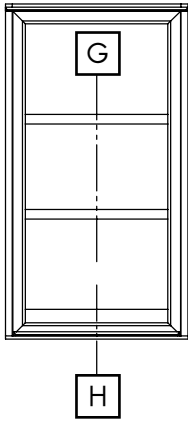

160mm Bottom rail adaptor is optional and is only required if a deeper bottom rail is required, i.e. for a letter plate etc.

Muntin bar profile is optional to create lay bar or Muntin with a 50mm sight line (24mm glazing only).

NOTE: These profiles can be used on centre pivot or rebate doors. (Centre Pivot shown)

Cutting Sizes

See page 4-3 for 2826 160mm bottom rail adaptor.

Following is for Muntin bar only (276, 277 & 278).

Width

Single door
Door opening minus 173.5

Double Door
Door opening minus 344, then divide by 2.

Height

Single/Double door
Door opening minus (173.5 + 50mm for every horizontal muntin) then divide by number of horizontal panes.

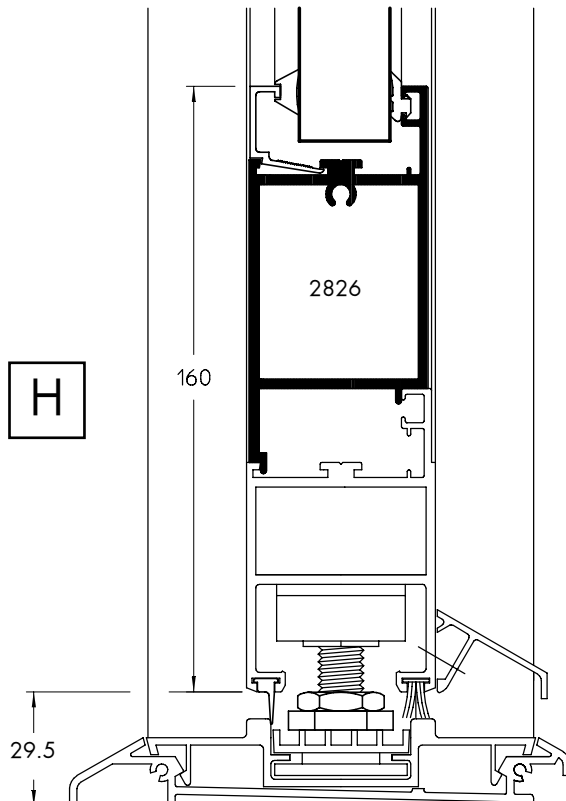









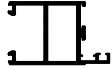







Total glass allowance 24mm

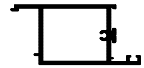

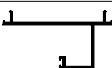
Parts List

High Performance Door

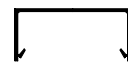
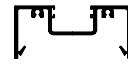
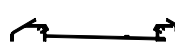

Profiles

Illustration	Part No	Description
	2810	Door leaf frame
	2811	Stile clip cover
	2812	Double glazing bead
	2813	Single glazing bead
	2816	weather bar
	2817	Threshold
	2819	Rebated threshold
	2820	Rebate adaptor (16mm pocket)
	2821	Rebate adaptor (32mm pocket)
	2822	Pvc rebate clip cover (white, black or grey)
	2823	150mm mid rail
	2826	160mm bottom rail adaptor
	2827	Slave stile rebate adaptor
	2829	Rebate head closer cover
	2830	Anti finger trap adaptor
	2832	Anti finger trap jamb liner
	2951	16mm pocket frame
	2954	Plain head closer cover
	2957	Plain frame
	2981	32mm pocket frame
	2994	Sub cill

Profiles (cont)

Illustration	Part No	Description
	276	Muntin bar
	277	Clamp plate for 276
	278	Capping for 277

Replacement components with fittings

Illustration	Part No	Description
	202/400	Lock stile R/H
	202/401	Lock stile L/H
	202/402	Hang and slave stile
	202/406	Bottom rail
	202/407	Top rail
	202/403	Lock stile clip cover
	202/404	Slave stile clip cover (Pivot Door)
	202/405	Hang stile clip cover (Rebate Door)
	202/409	Hang stile clip cover (Pivot Door)
	202/417	Slave stile rebate adaptor (Rebate Door)

Minimal outer frame profiles shown, see Ground floor treatments manual for full range of available outer frame profiles.

Parts List

High Performance Door

Door Kits

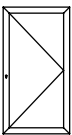
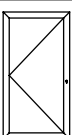
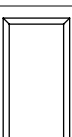
Illustration	Part No	Description
	202/470	Pivot lock leaf kit - R/H 2137 High x 1103 Wide
	202/472	Rebate lock leaf kit - R/H 2137 High x 1103 Wide
	202/471	Pivot lock leaf kit - L/H 2137 High x 1103 Wide
	202/473	Rebate lock leaf kit - L/H 2137 High x 1103 Wide
	202/474	Pivot Slave leaf kit - Universal 2137 High x 1103 Wide
	202/475	Rebate Slave leaf kit-Universal 2137 High x 1103 Wide



Each leaf kit contains metal and assembly fixings.

Glazing beads, gaskets, outer framing, threshold, fixings, handles and appropriate closer hardware must be ordered separately to complete the installation.



Lock leaves are handed as viewed from the outside.

Rebate slave leaf kits have keep preparation omitted to avoid handing. Refer to page 4-5 for machining details.











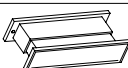
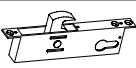

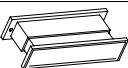

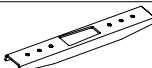
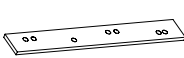

Additional Kits

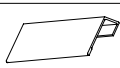
Illustration	Part No	Description
	202/476	150mm Mid rail kit (981mm long)
	202/478	160mm Bottom rail adaptor (981mm long)

Components

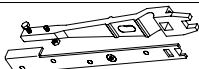
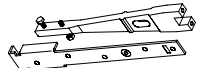
Illustration	Part No	Description
	204/28	Unregistered double profile cylinder
	204/30	Escutcheon plate
	204/33	Unregistered profile cylinder with thumb-turn











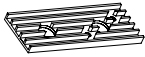

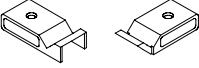

Components (cont)

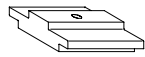
Illustration	Part No	Description
	204/41	Key blank
	202/07	Letter-plate
	202/11	Security hook bolt
	202/14	Flush bolt
	202/38	Hinge reinforcement bkt
	202/47	Wide Letter-plate
	202/48	Ribbed Pad handle 300mm long
	202/52	Pad handle fixing pack (Pack of 10)
	202/59	Door stop (fit with No 8 x 1" csk screw)
	202/65	Armour strike for jamb
	202/81	Head closer arm packing plate (Anti finger trap)
	202/104	Plain pad handle 300mm long
	202/105	Plain pad handle 200mm long
	202/106	Broad pad handle 230mm long
	202/107	Tube handle assembly 2095mm long
	202/192	Dorma closer cover plate
	202/232	Closer arm and pivot set
	202/234	Anti finger trap closer arm and pivot set
	202/408	Pivot Threshold grill
	202/419	Bottom pivot locator
	202/420	Bottom pivot locator fixing plate





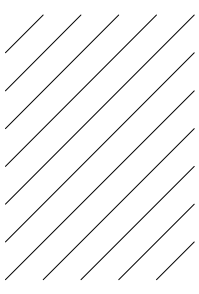

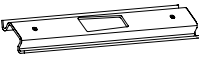
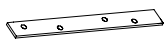





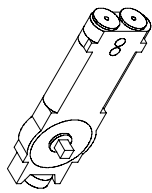
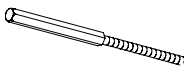
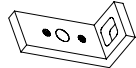
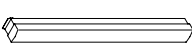

Parts List

High Performance Door

Components (cont)

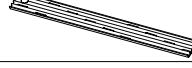
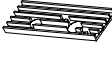
Illustration	Part No	Description
	202/421	Pivot door cill flushbolt locator (double door)
	202/422	Pivot door cill flushbolt locator fixing plate
	202/430	Corner cleat pack with corner ties (4 off)
	202/436	Exit device cill locator (single pivot)
	202/437	Exit device cill locator (double pivot)
	202/441	Anti finger trap clip
	202/442	Anti finger trap jamb liner fixing block
	202/443	Anti finger trap bottom pivot locator
	202/444	Lock mounting pillar
	202/445	Corner tie
	202/447	Hang stile end cap (Pivot doors)
	202/450	End stop for 2994 (fit with No 8 x 3/4" csk screw)
	202/452	Muntin to frame joint adaptor
	202/456	Pivot lock leaf accessory pack
	202/457	Rebate lock leaf accessory pack
	202/458	Pivot slave leaf accessory pack
	202/459	Rebate slave leaf accessory pack
	202/462	Weather bar end cap L/H
	202/463	Weather bar end cap R/H
	202/465	Armour strike for slave stile
	202/466	4mm Arm packer plate for rebate doors with closers





Components (cont)

Illustration	Part No	Description
	202/467	Cover plate for rebate door (R/H o-out)(L/H o-in)
	202/468	Cover plate for rebate door (L/H o-out)(R/H o-in)
	202/469	Closer arm for rebate doors
	202/481	Glazing packer
	202/496	Dorma Rts85 EN3 hold
	202/497	Dorma Rts85 EN3 no hold
	202/498	Dorma Rts85 EN4 hold
	202/499	Dorma Rts85 EN4 no hold
	202/500	Dorma Rts85 EN5 hold
	202/501	Dorma Rts85 EN5 no hold
	202/505	Adams Rite 4022 threshold bolt
	202/515	Flush bolt guide bracket
	202/520	42" Push bar
	202/521	48" Push bar
	202/522	L/H Door push pad
	202/523	R/H Door push pad
	202/524	L/H Door exit device gear
	202/525	R/H Door exit device gear
	202/528	Dorma Hinge
	202/530	Threshold grill for rebate door (R/H o-in)(L/H o-out)
	202/531	Threshold grill for rebate door (L/H o-in)(R/H o-out)
	202/532	Cill flushbolt locator rebate door (L/H o-out)(R/H o-in)
	202/533	Cill flushbolt locator rebate door (R/H o-out)(L/H o-in)
	202/534	Flushbolt locator fixing plate (double rebate)
	202/535	Pivot door exit device cill locator (single rebate)















Parts List

High Performance Door

Components (cont)

Illustration	Part No	Description
	318/25	Muntin spacer moulding
	318/40	Muntin to muntin joint moulding
	318/68	Muntin bar cruciform joint fixing pillar
	N/A	Adams Rite 8650 Escutcheon
	N/A	Adams Rite 4055 Arel extended cylinder plus 13mm trim ring

Weatherseals and Gaskets

Illustration	Part No	Description
	105/37	Door leaf woolpile
	105/39	Groove trim (leaf)
	105/75	Groove trim (anti finger trap)
	105/87	6mm wedge gasket (blue)
	105/88	5mm wedge gasket (yellow)
	105/89	4mm wedge gasket (white)
	105/90	3mm wedge gasket (black)
	105/91	2mm retained gasket (black)
	105/94	7mm wedge gasket (black)
	105/134	Compression gasket for 277 clamp plate
	105/135	2.25mm wedge gasket (grey)
	105/140	3mm retained gasket (green)
	105/148	Rebate to door leaf weatherseal
	105/184	Door leaf inner seal

Assembly Screws

Size/Part No	Head	Description
No 6 x 1/2" ST612PPSS	Pan	Weather bar
No 8 x 3/8" ST838PPSS	Pan	Flush bolt locater
No 8 x 1/2" ST812CPSS	Csk	Muntin bar joint
No 8 x 1/2" ST812PPSS	Pan	Rebate and Anti-finger trap adaptor
No 8 x 5/8" ST858CPSS	Csk	Exit device cill locater
No 8 x 5/8" ST858TCPSS	Csk	Blunt end for muntin bar
No 10 x 1-1/2" ST10112CPSS	Csk	Lock and muntin bar
No 10 x 2" ST102PPSS	Pan	Anti-finger jamb liner
No 12 x 1/2" ST1212CPSS	Csk	Closer arm fixing
No 12 x 3/4" ST1234PPSS	Pan	Floor pivot shoe fixing
No 12 x 1" ST121PPSS	Pan	Mid rail fixing
No 12 x 2" ST122PPSS	Pan	Outer frame corner and bottom rail adaptor
M5 x 10 MM510CPSS	Csk	Armour strike and flushbolt
M5 x 35 MM535CPSS	Csk	Cylinder and closer cover plate
M5 x 45 MM545CPSS	Csk	Muntin bar joint
M6 x 12 MM612CPSS	Csk	Head/Transom bracket
M6 x 16 MM616CPSS	Csk	Closer arm
M6 x 20 MM620PPSS	Pan	Floor pivot shoe
M8 x 20 MM820SCTLSS	Socket	Corner cleat tightening
8/32 UNC x 5/16" MU832516CPSS	Csk	Clip cover to lock
M6 NUTSERT NM6ZN	Flush	Closer to door leaf and head/transom to jamb
M6 Flange Nut M6SFSS	Hex	Closer frame bracket

Parts List

Tooling

Part No	Description
202/155	Drill Jig - Head/transom,lock & hanging jamb
202/161	Nutsert insert tool
202/166	Drill jig - top arm/floor pivot (anti finger trap)
202/167	Drill jig - anti finger trap clip fixing holes
202/482	Router plate - corner cleat & lock preparation
202/483	Router plate - flushbolt & lock keep prep
202/485	Drill jig - hinge fixings in stiles and jambs
202/486	Drill jig - lock fixing holes
202/487	Drill jig - pad handle fixing holes in stiles
202/488	Drill jig - top arm floor pivot in top/btm rails
202/490	Drill jig - mid rail and bottom rail adaptor
202/491	Drill jig - flushbolt and lock threshold bolt
202/492	Drill jig - closer arm in top rail (rebated)
202/494	Drill jig - exit device gear in stile
202/495	Drill jig - Push pad or panic bar

Drill sizes

Size	Description
3.0	Weather bar fixing holes
3.5	Letterplate / rebate & anti-finger adaptor
4.1	Lock fixing holes
4.8	Top and bottom head closer prep in rails
5.0	Exit device / armour strike / jamb liner
5.2	Head/transom & clip cover preparation
6.0	Mid rail/bottom rail adaptor & Outer-frame
6.5	Head/transom preparation
6.8	Handle fixing holes
7.0	Closer arm for rebated door
9.0	Hinge fixing holes
9.5	Transom closer & nutsert holes in rails
12.0	Threshold bolt hole & mid/btm rail adaptor
5.0	Router cutter for router plate (202/482 & 202/483) preparation

Full Size Profile Illustrations

High Performance Door

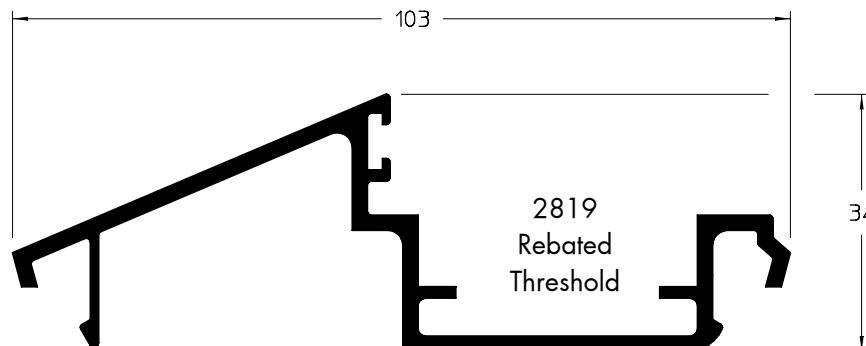
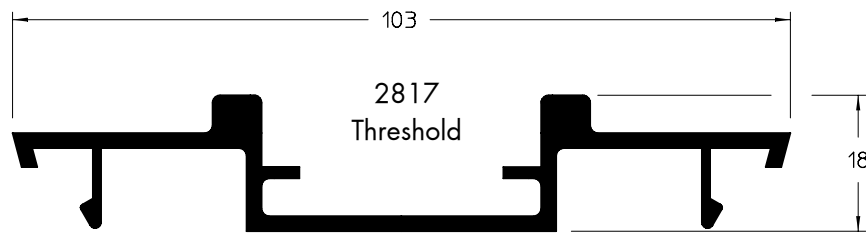
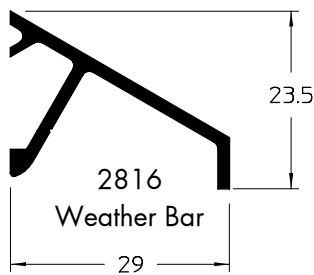
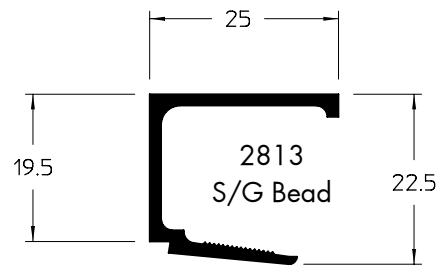
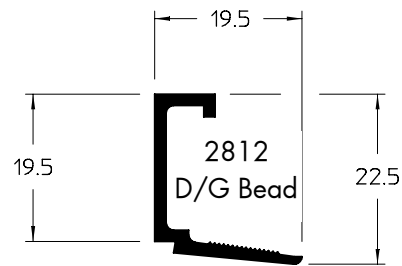
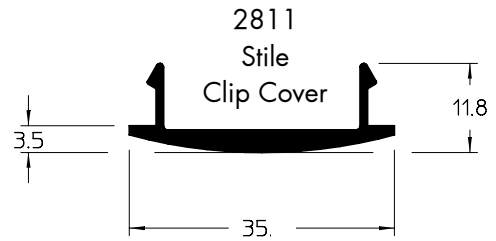
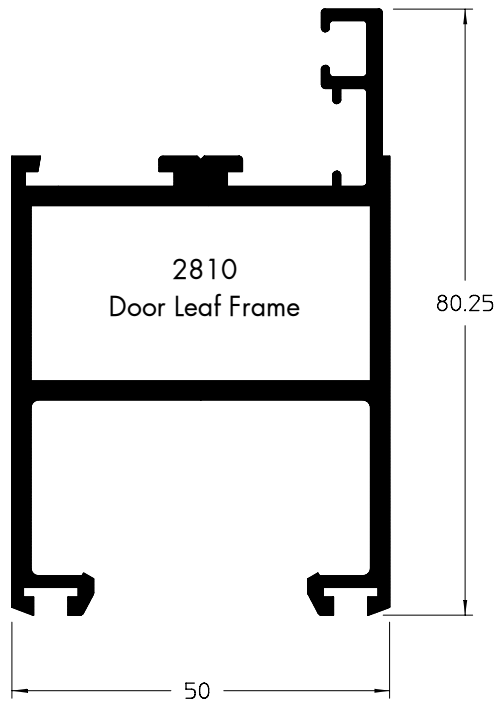

Full Size Profile Illustrations (cont)

High Performance Door

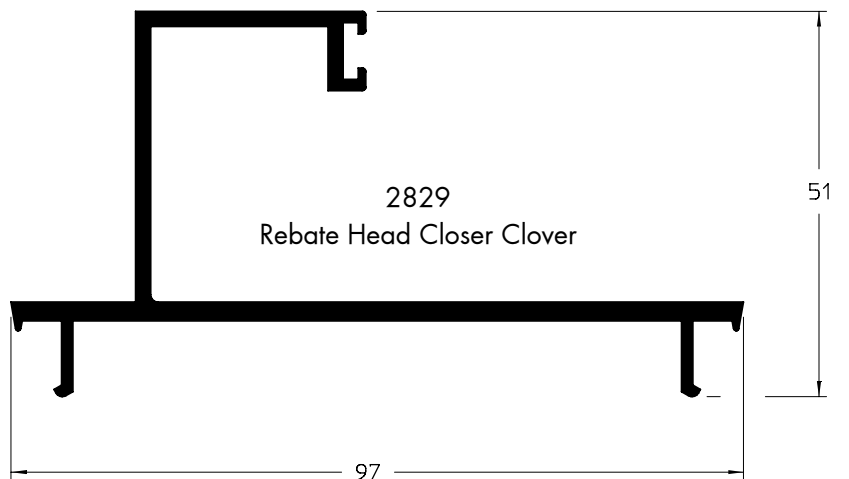
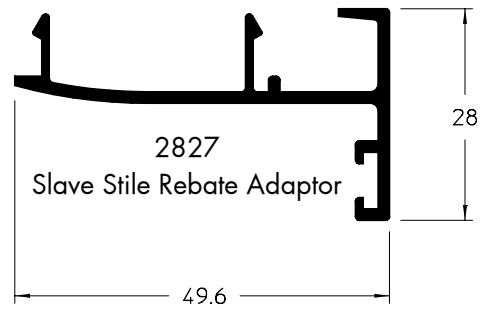
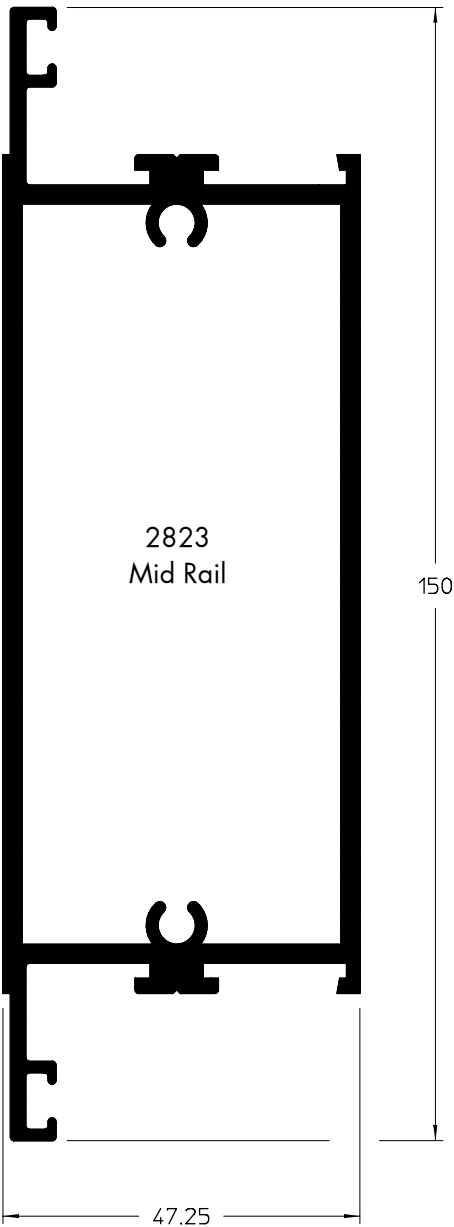
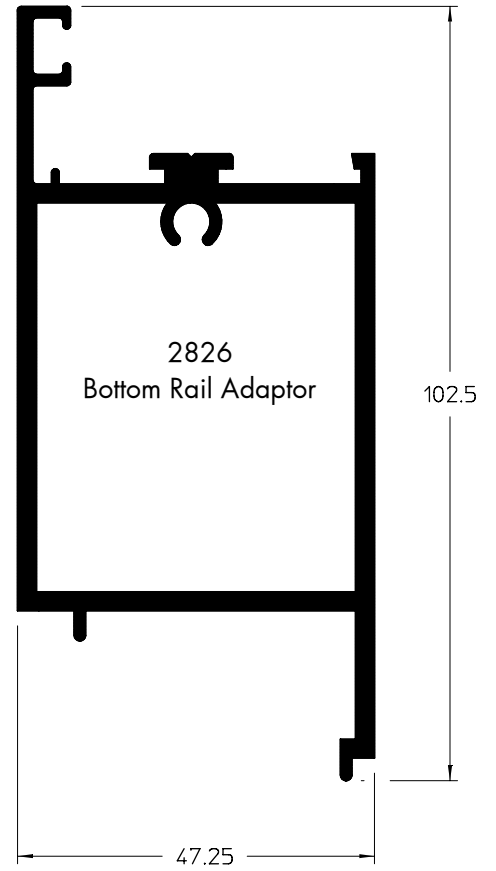
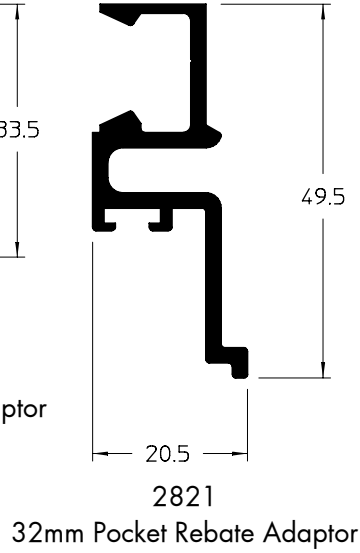
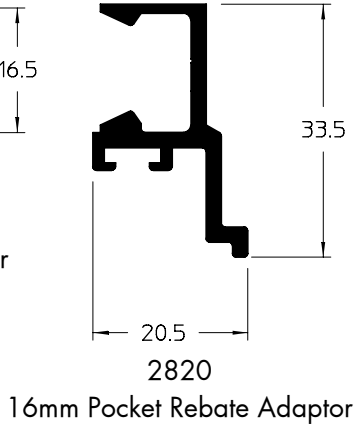
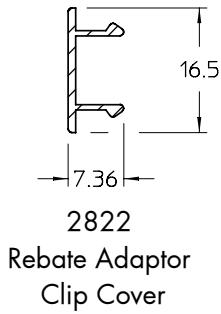

Full Size Profile Illustrations (cont)

For full range of frame profiles, refer to current ground floor treatments manual.

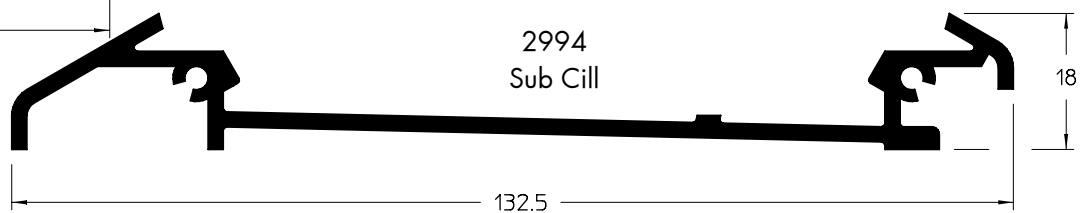
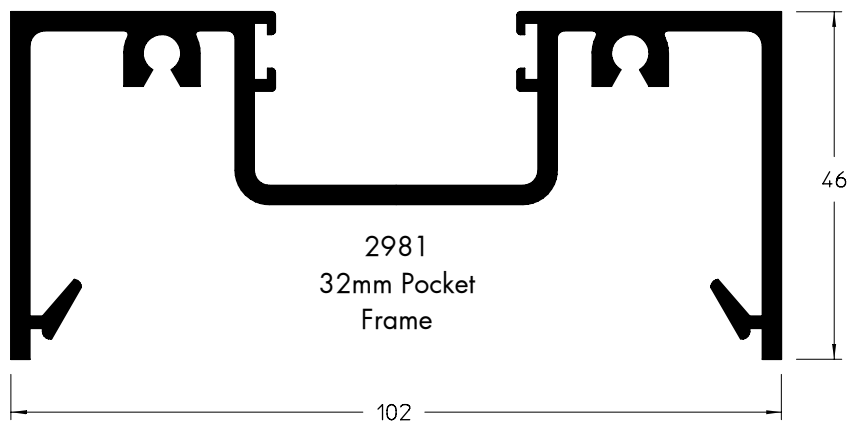
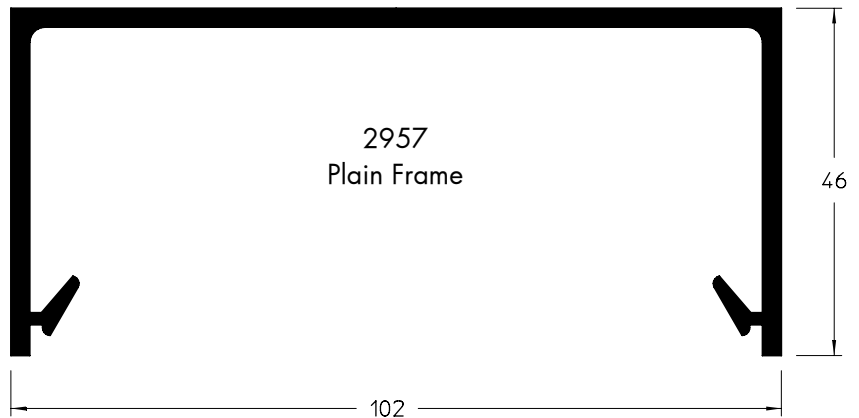
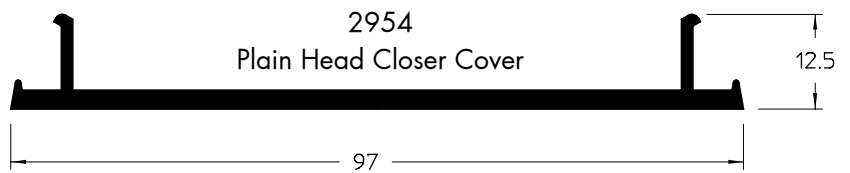
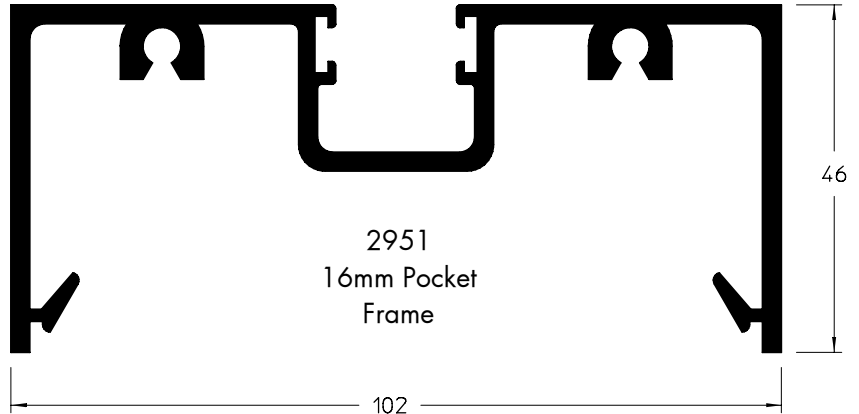
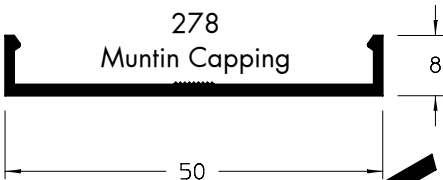
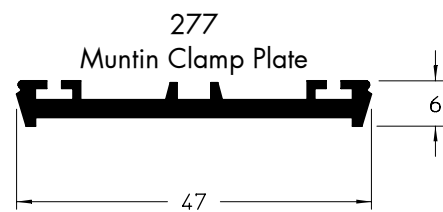
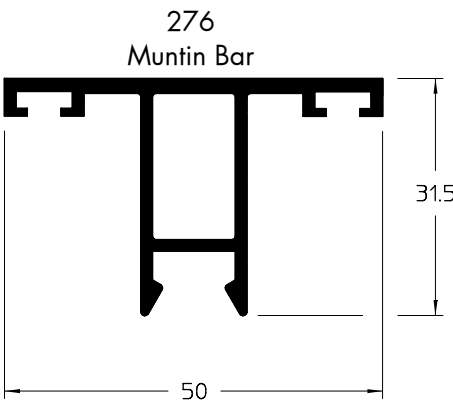
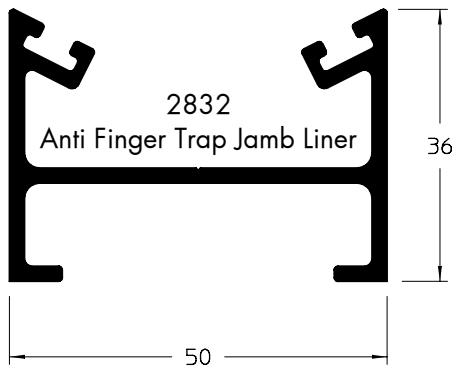
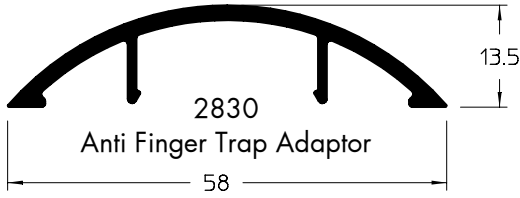

THIS PAGE INTENTIONALLY LEFT BLANK

Metal & Glass Cutting Calculations

TYPICAL PIVOT DETAILS SHOWN.

Note:- Door leaf glass and metal calculations are the same for centre pivot and rebate doors.

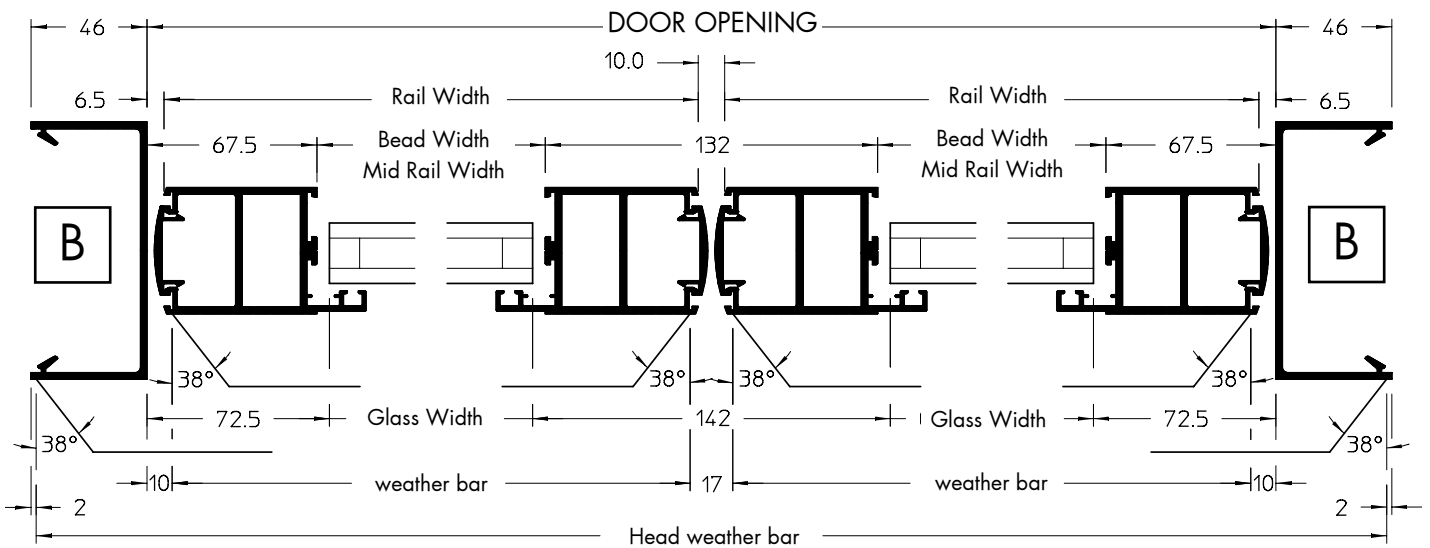
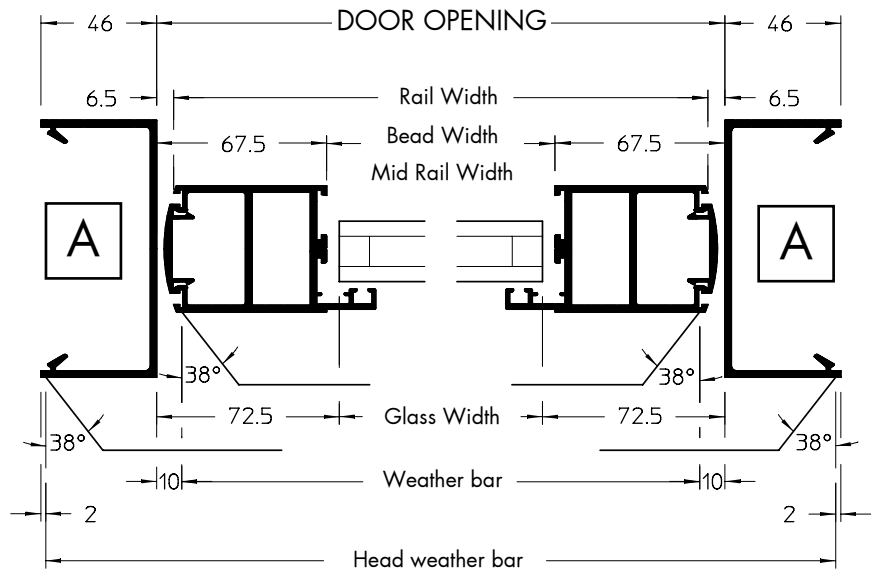
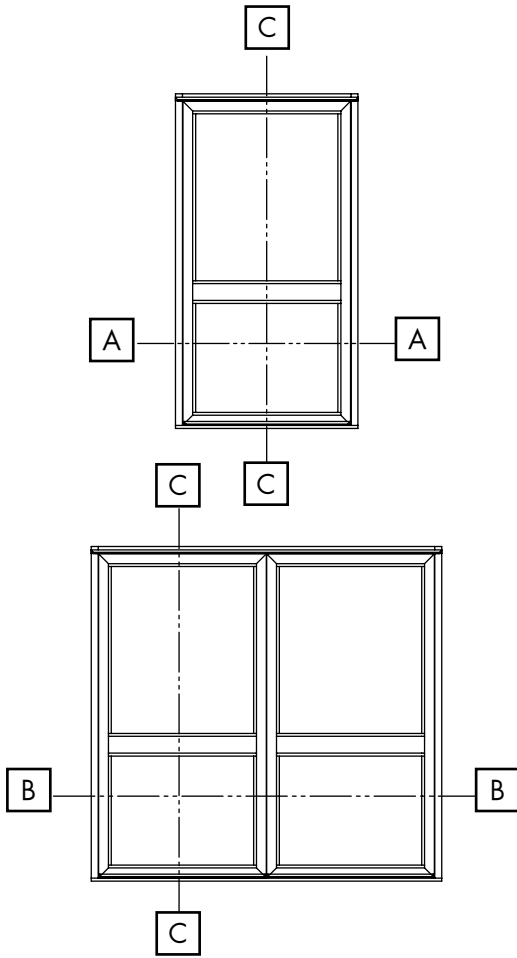

FOR MUNTIN BAR CUTTING CALCULATIONS SEE PAGE 2-10.

When manufacturing doors from bar length profiles, the lengths ordered must include an allowance of 37mm at each end of any profile which will have a powder coat or anodised finish to allow for jig marks.

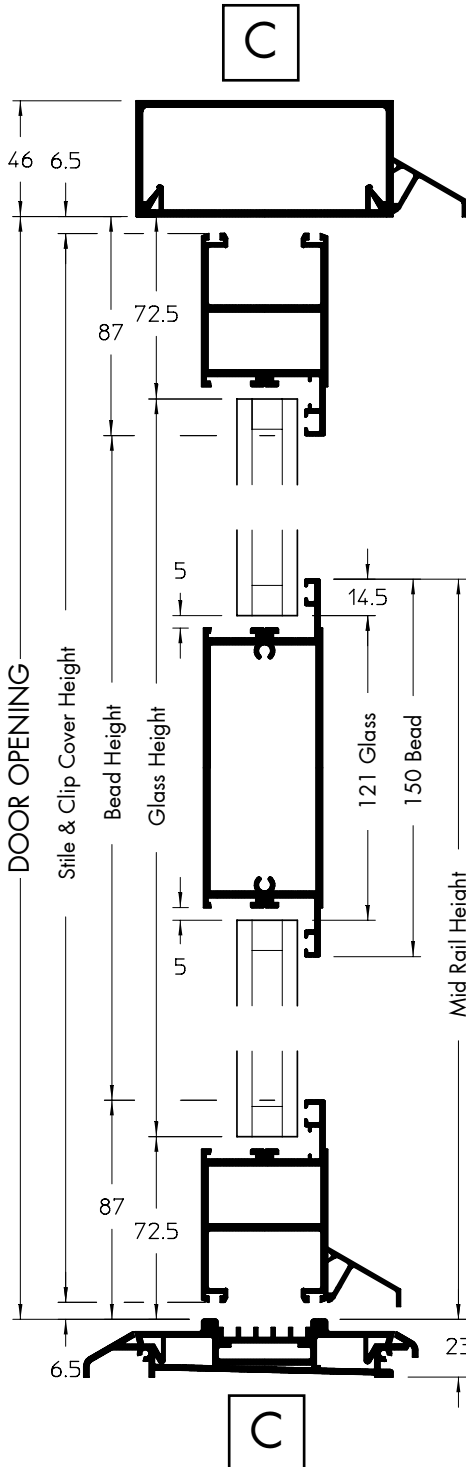

Glass Cutting Sizes for Door Leaves.

(All calculations taken from door opening).

WIDTH

Single Door	Door opening minus 145mm
Double Door	Door opening minus 287mm then divide by 2
<i>Reduce Glass width by a further 32.5mm for anti finger trap (2830-2832).</i>	

HEIGHT

Door without mid rail	
Single pane	Door opening minus 145mm*
Door with mid rail	
Top pane	Door opening minus (mid rail height + 58mm)
Bottom pane	Mid rail height minus 208mm*
<i>* Reduce glass height by a further 80mm for bottom rail adapter (2826).</i>	

Bar Length Calculations for Door Leaves.

(All calculations taken from door opening).

WIDTH

<i>Top & Bottom Rails (2810) mitre cut @ 45°</i>	
Single door	Door opening minus 13mm
Double door	Door opening minus 23mm then divide by 2
<i>Reduce rail width by a further 32.5mm for anti finger trap (2830-2832).</i>	

Mid Rail (2823), Bottom Rail Adapter (2826), Glazing Bead (2812-2813)

Single Door	Door opening minus 135mm
Double door	Door opening minus 267mm then divide by 2
<i>Reduce rail width by a further 32.5mm for anti finger trap (2830-2832).</i>	

Door Leaf weather bar (2816) mitre cut @ 38°

Single Door	Door opening minus 20mm
Double Door	Door opening minus 37mm then divide by 2
<i>Reduce weather bar by a further 90mm for anti finger trap (2830-2832)</i>	
<i>Reduce weather bar by a further 15mm for rebate open in doors.</i>	

HEIGHT

<i>Stiles (2810) mitre cut @ 45°</i>	
Single & Double Door	Door opening minus 13mm
<i>Rebate Adapter (2827), Clip Cover (2811), Anti finger trap adapter (2830)</i>	
Single & Double Door	Door opening minus 13mm
<i>Reduce pivot door hang stile clip cover by a further 50mm for end cap.</i>	

Glazing Bead (2812 & 2813)

Door without mid rail	Door opening minus 174mm*
Door with mid rail :-	
Top pane bead	Door opening minus (mid rail height + 87mm)
Bottom pane bead	Mid rail height minus 237mm*
<i>* Reduce bead height by a further 80mm for bottom rail adapter (2826).</i>	

Beading sizes are exact but due to cutting tolerances we advise that they are cut oversize and tailored to actual conditions when fitted.

Bar Length Calculations for Outer Frame.

(All calculations taken from door opening).

WIDTH

Head-Transom/T-hold/Rebate adapter	Door opening
Sub cill (2994)	Door opening plus 92mm
Weather Bar (2816) mitre cut @ 38°	Door opening plus 88mm
Rebate-Plain cover plate	Single Door opening minus 350
	Double Door opening minus 700

HEIGHT

Jamb	Door opening plus 56
Rebate adapter/Anti finger trap liner	Door opening

Machining Door Leaf

Lock Stile (2810) & Clip Cover (2811)

R/H Lock prep shown, mirror prep on lock stile for L/H.

This dimension is taken from extreme edge of profile.

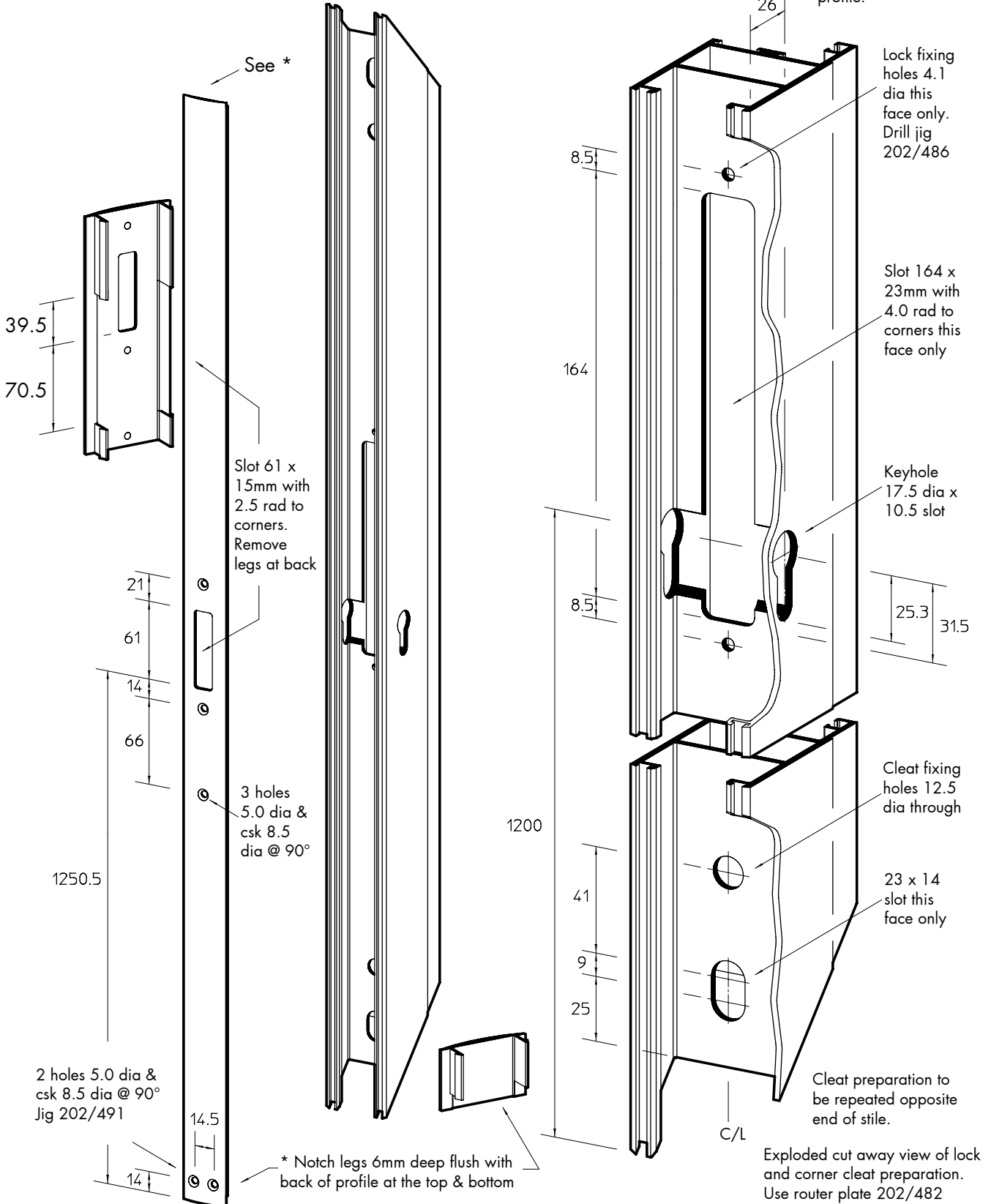

Machining Door Leaf

Slave Stile (2810), Clip Cover (2811) & Slave Stile Rebate Adaptor (2827)

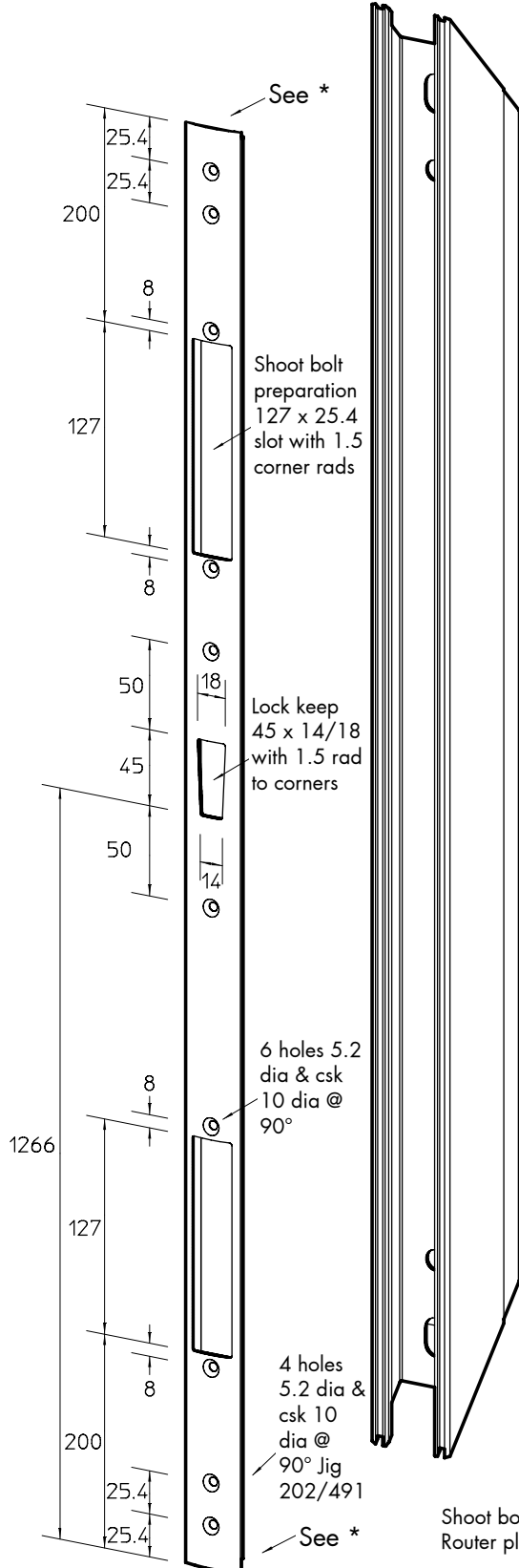

When using the slave stile rebate adaptor (2827) the machining is the same as the clip cover (2811) except for additional cut-outs shown. Also note that the adaptor is handed and the profile shown would fit a L/H open in door or a R/H open out door.

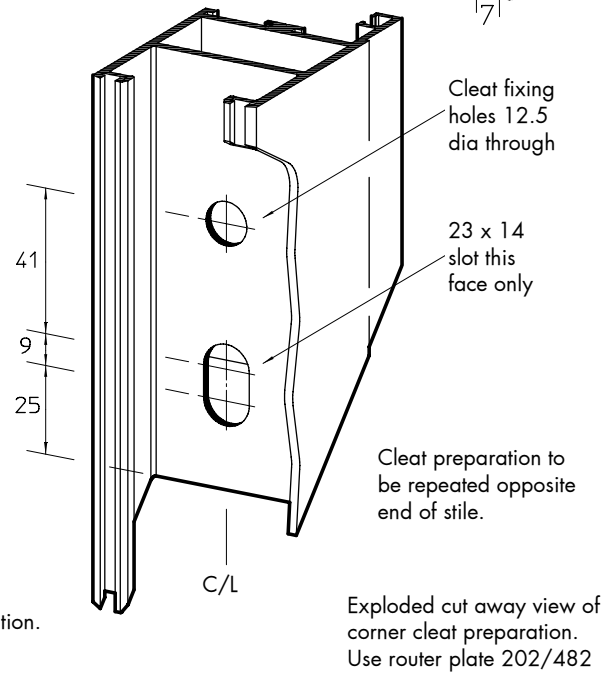
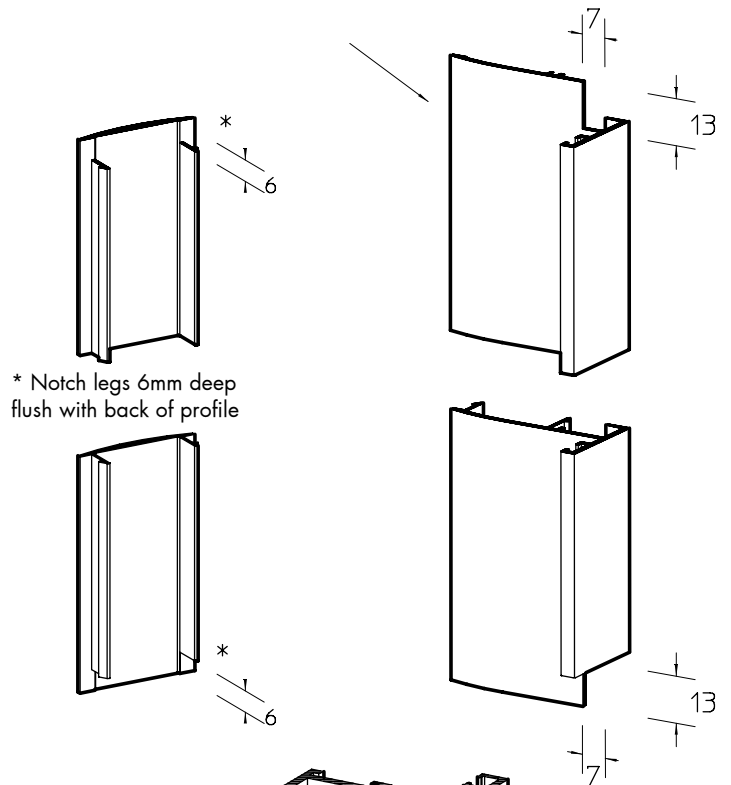

Shoot bolt & lock keep preparation.
Router plate 202/483

Machining Door Leaf

Hang Stile (2810) and Clip Cover (2811)

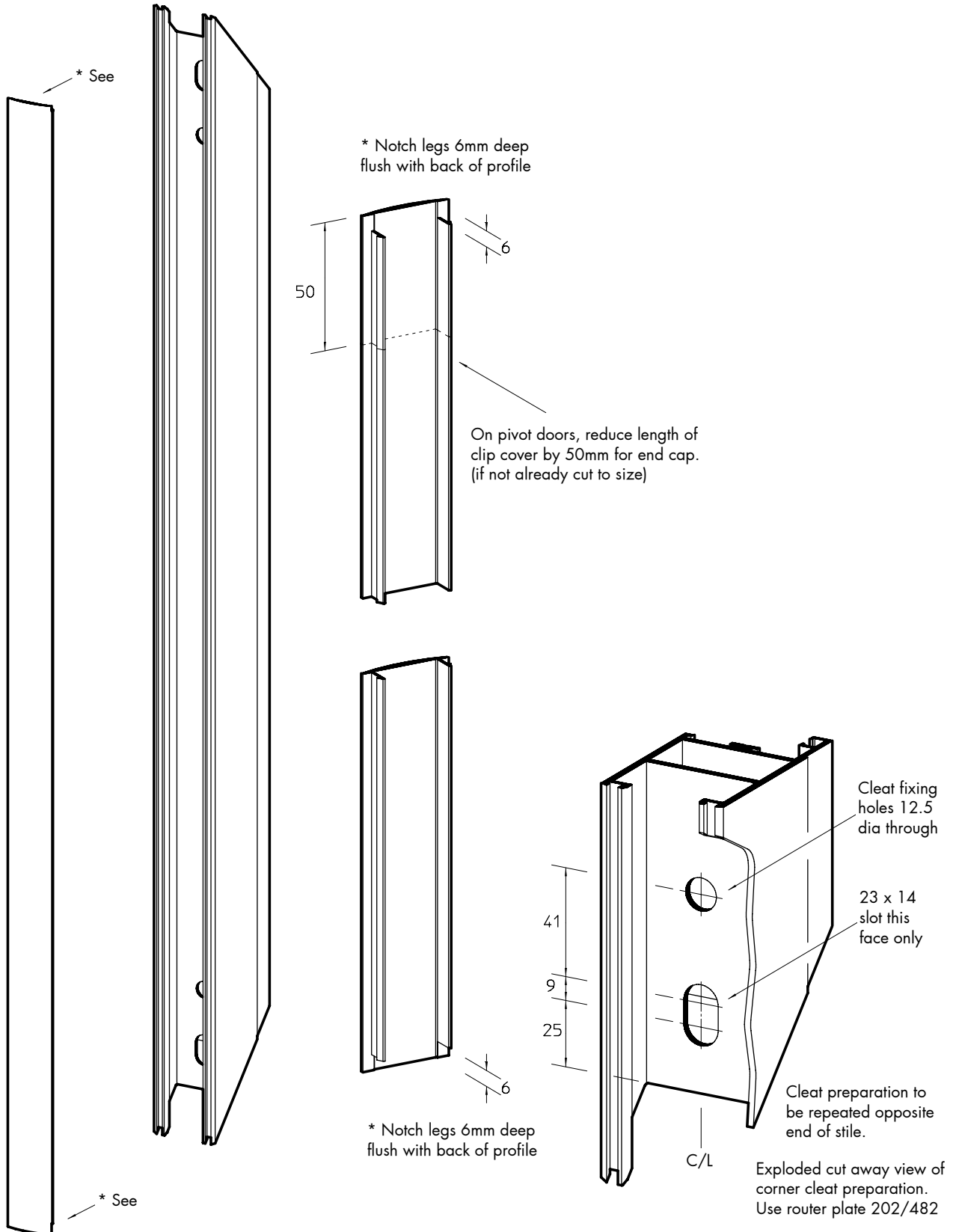

Machining Door Leaf

Hang Stile (2810) Additional, Anti Finger Trap and Hinges.

Hinge Preparation for Rebate Doors.

Handing of door leaf must be determined before machining hang stile for pivot hinges. L/H open out door preparation shown.

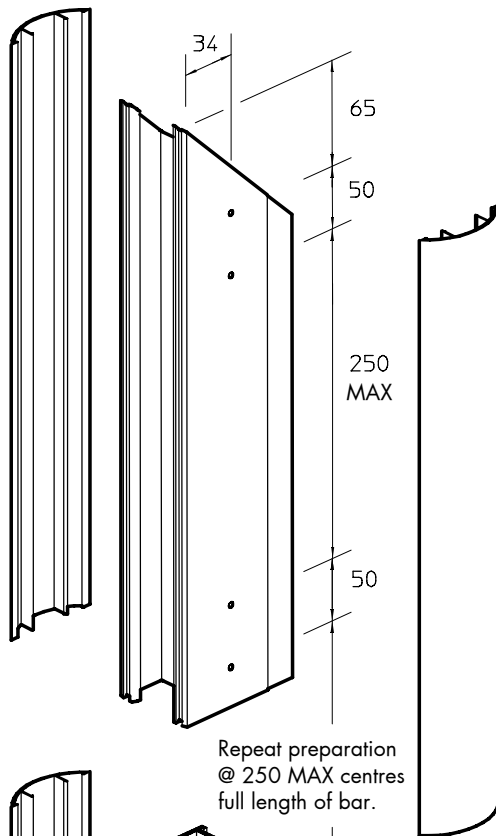

Repeat preparation @ 250 MAX centres full length of bar.

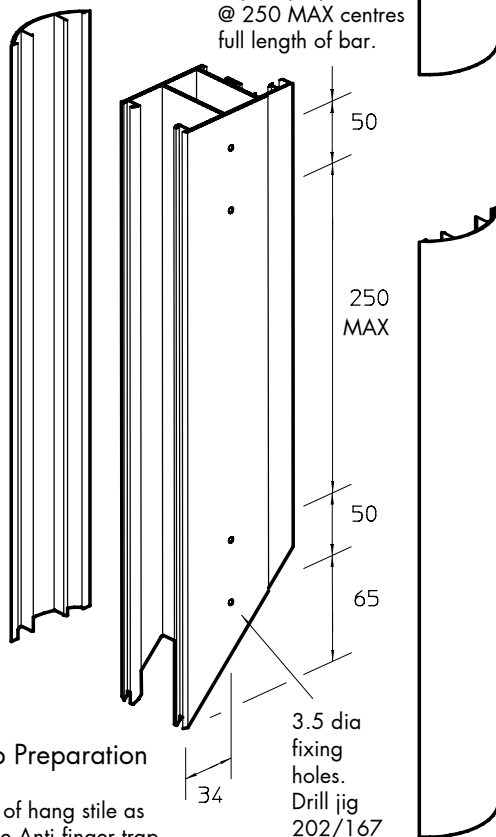

Anti Finger trap Preparation for Pivot doors.
Prepare both sides of hang stile as shown to enable the Anti finger trap adaptor to be fitted both sides of stile.

3.5 dia fixing holes.
Drill jig 202/167

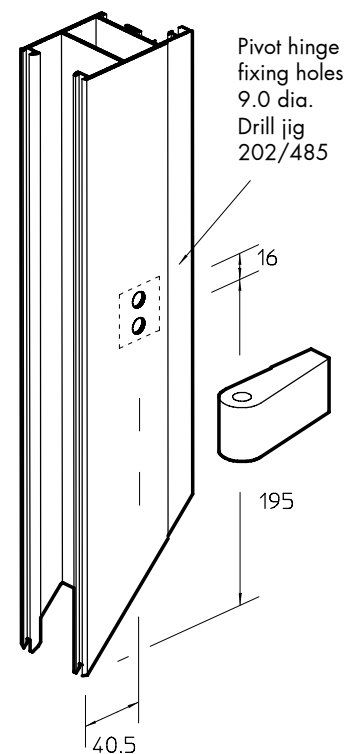
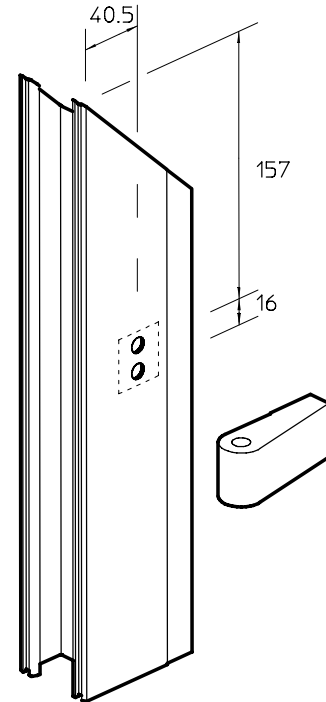

Pivot hinge fixing holes 9.0 dia.
Drill jig 202/485

Machining Door Leaf

Top & Bottom Rail (2810)

All rails to have cleat and drainage preparation as shown, refer to additional machining below or opposite page for head closer preparation.

TOP RAIL

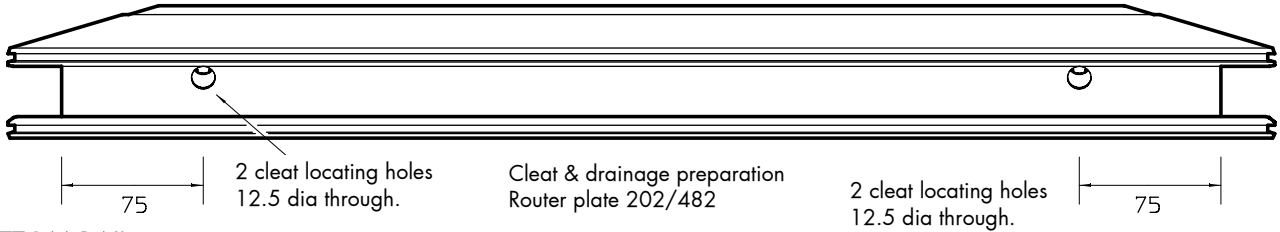

BOTTOM RAIL

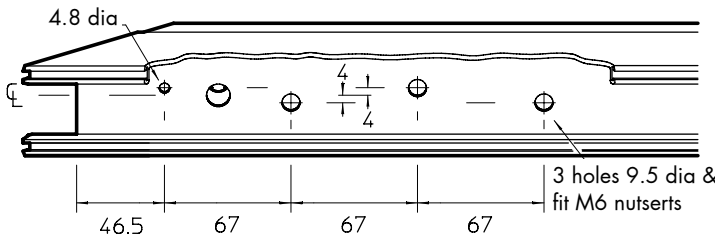
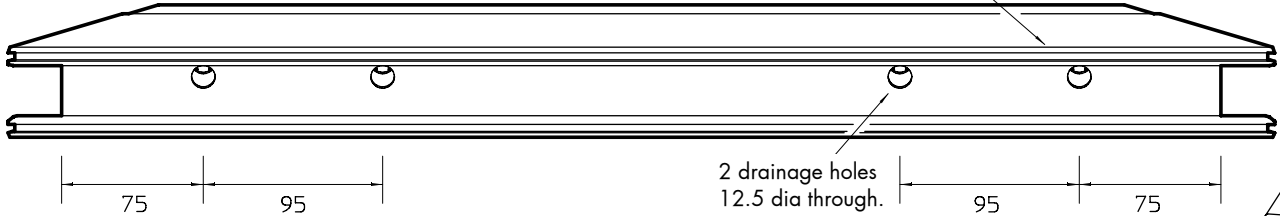

TOP RAIL

Additional machining for centre pivot doors. Preparation shown for right hand leaf - for left hand leaf prepare opposite end of bar to that shown (do not mirror prep). Drill jig 202/488

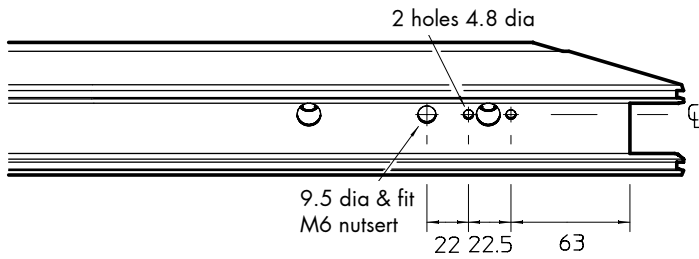

BOTTOM RAIL

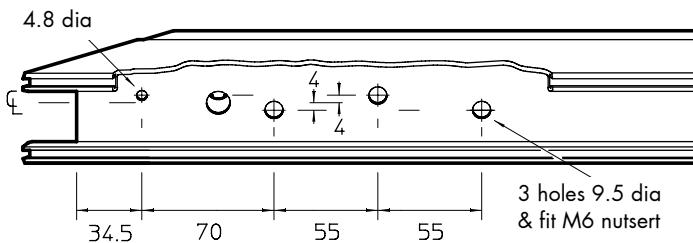

TOP RAIL

Additional machining for centre pivot doors with Anti-finger trap stiles. Preparation shown for right hand leaf - for left hand leaf prepare opposite end of bar to that shown (do not mirror prep). Drill jig 202/166

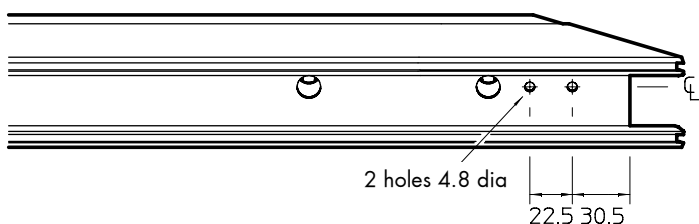

BOTTOM RAIL

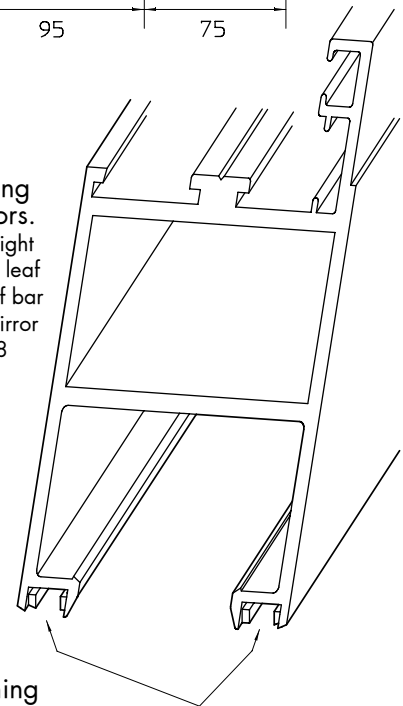

File out ends of weatherpile grooves both ends of **All** rails to allow weatherpiles etc. to be inserted into stiles after door assembly.

Machining Door Leaf

Top & Bottom Rail (2810) & Hang Stile (2811) Additional
(overhead closer into rebated door)

Preparation shown for L/H open out door,
prep opposite end of bar for R/H open out.

Trim off corner of
hang stile flush with
preparation in top rail.

Dotted prep shown for L/H
open in door, prep opposite
end of bar for R/H open in.

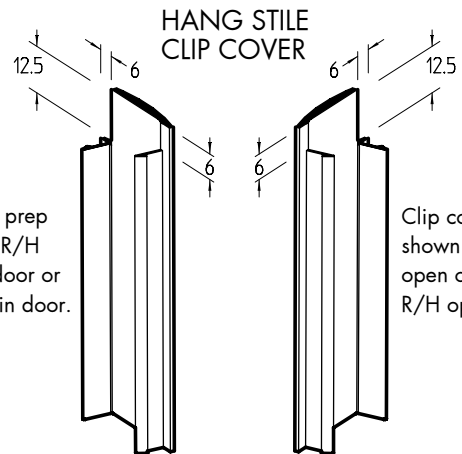
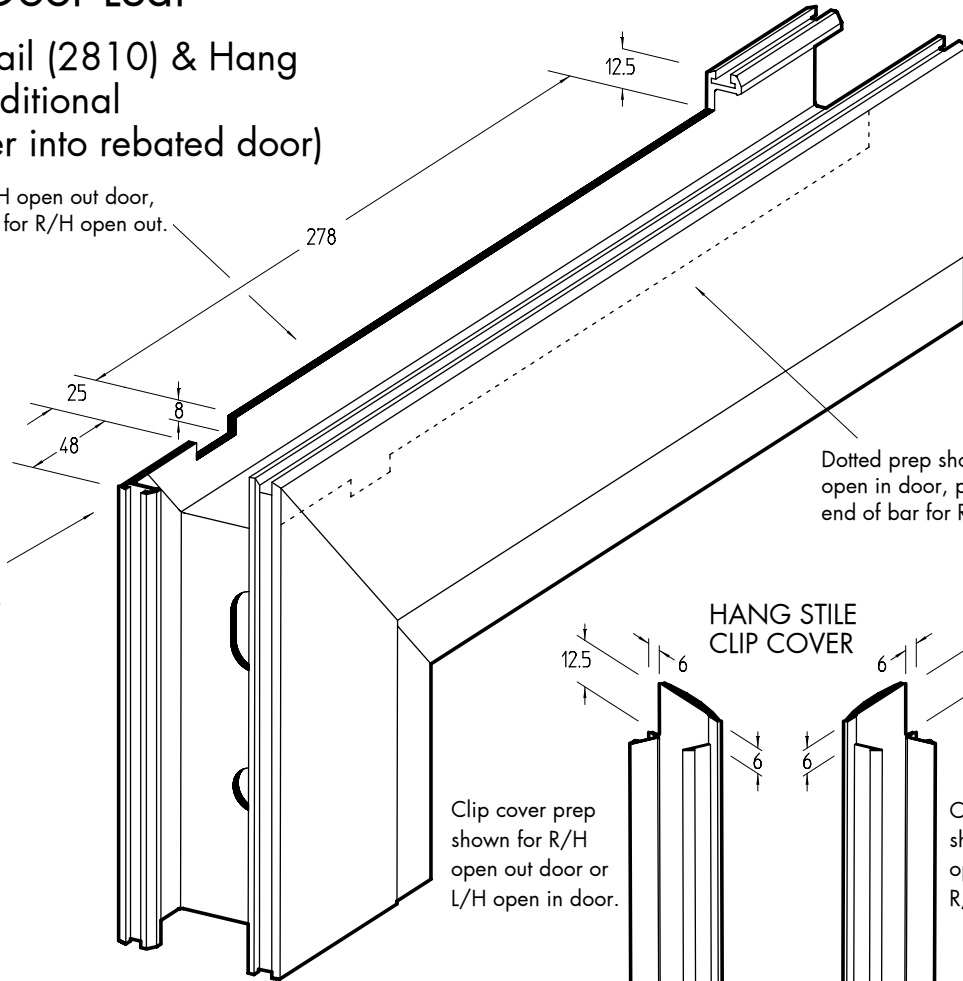

TOP RAIL L/H OPEN IN

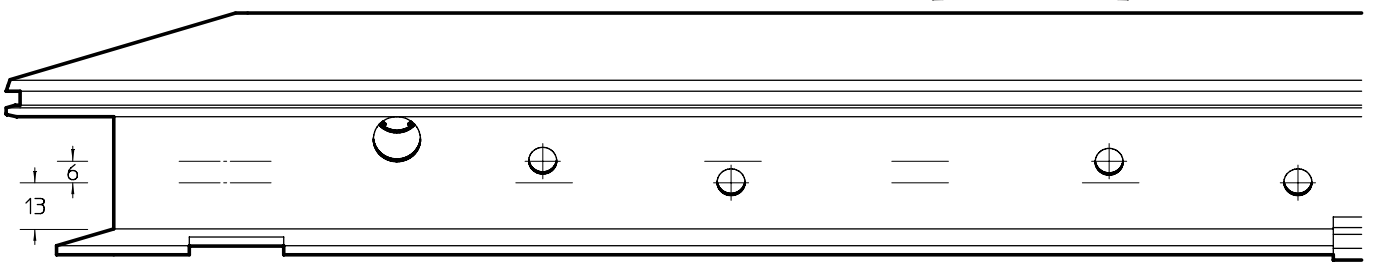

TOP RAIL L/H OPEN OUT

4 holes 7.0mm dia and
fit M5 nutserts

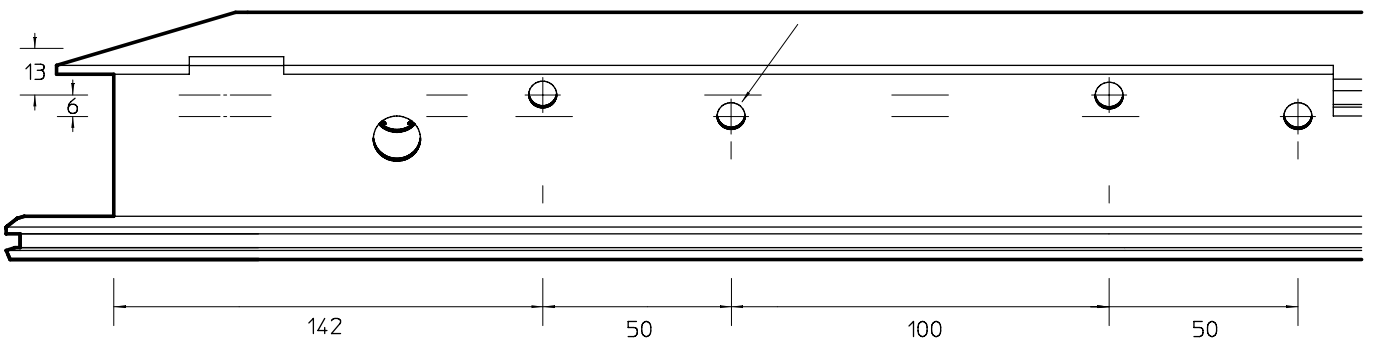

Machining Door Leaf

weather bar (2816)

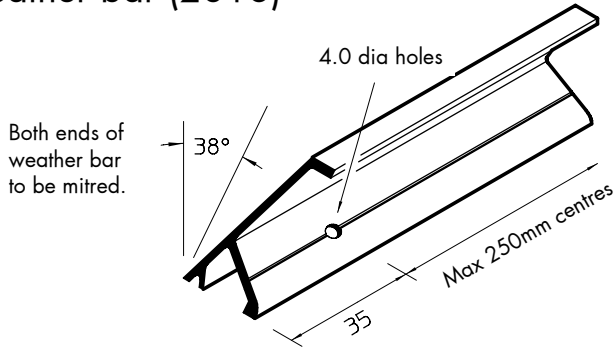

150mm Mid Rail (2823)

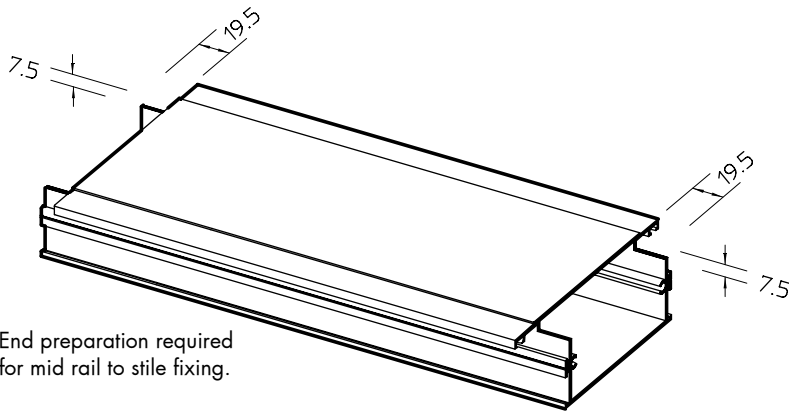

Preparation required in stiles (2810) for mid rail fixing.

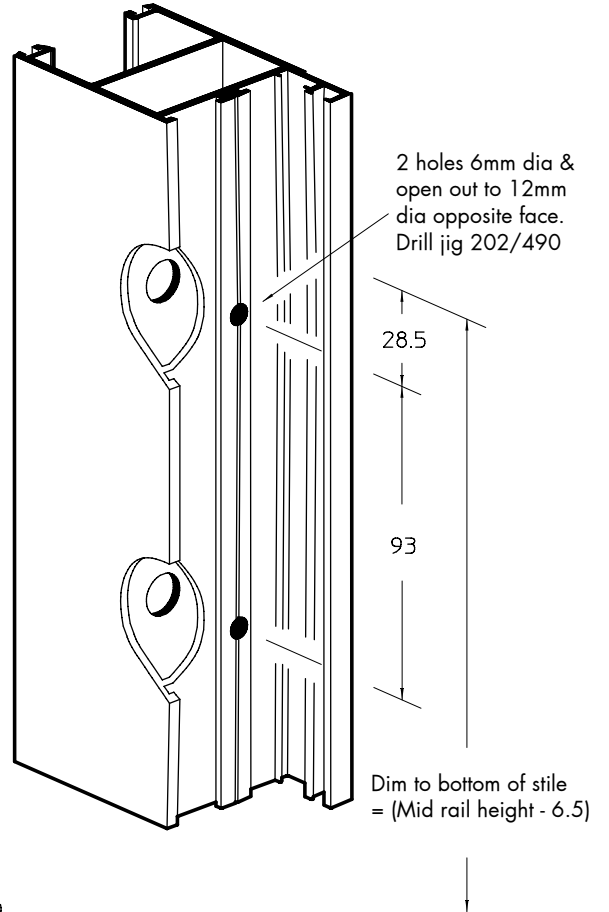

Additional preparation for 202/07 or 202/47 Letter plate if required.

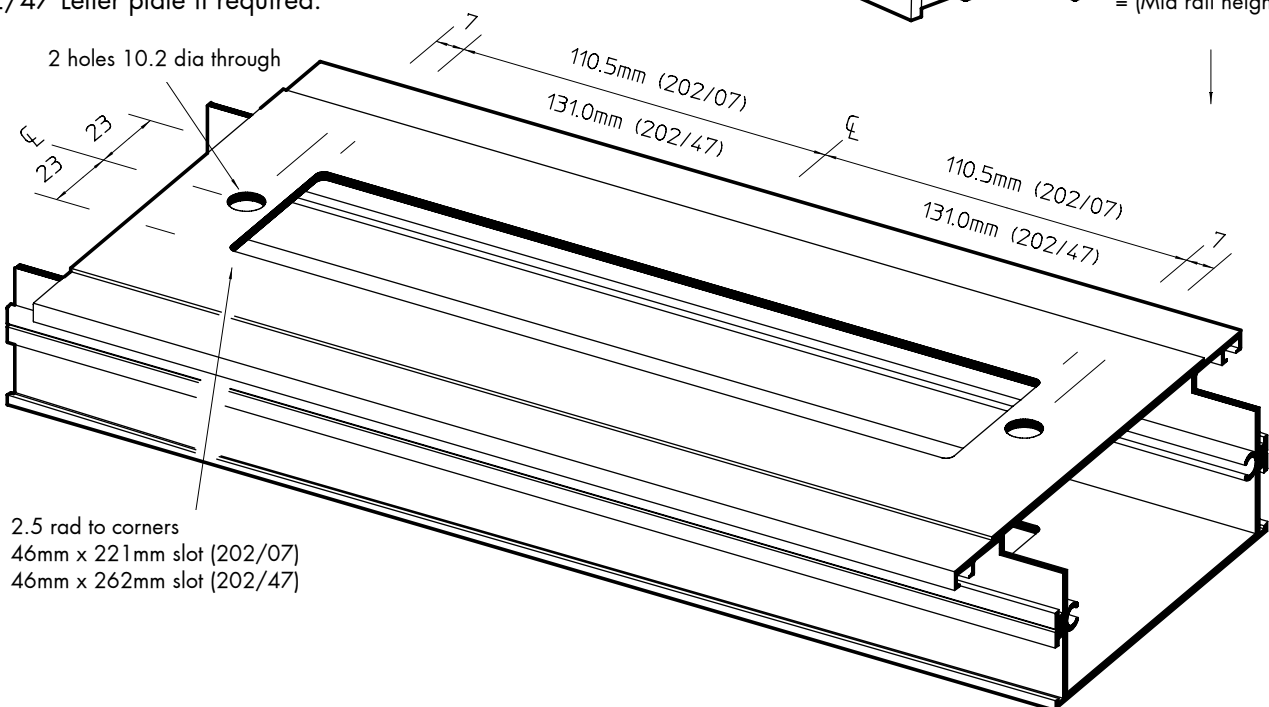

Machining Door Leaf

160mm Bottom Rail Adaptor (2826)

Preparation required in stiles (2810) for bottom rail adaptor.

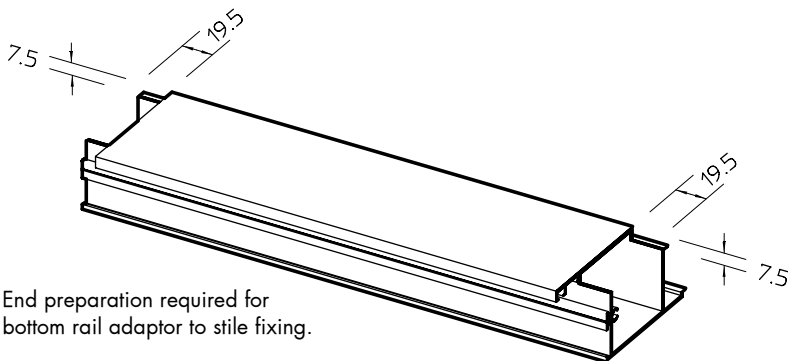

End preparation required for bottom rail adaptor to stile fixing.

Additional preparation for 202/07 or 202/47 letter plate if required.

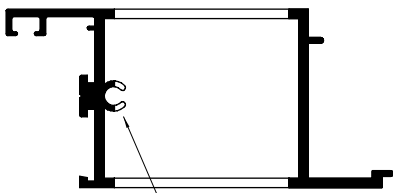

Remove screw spline in line with letter plate slot

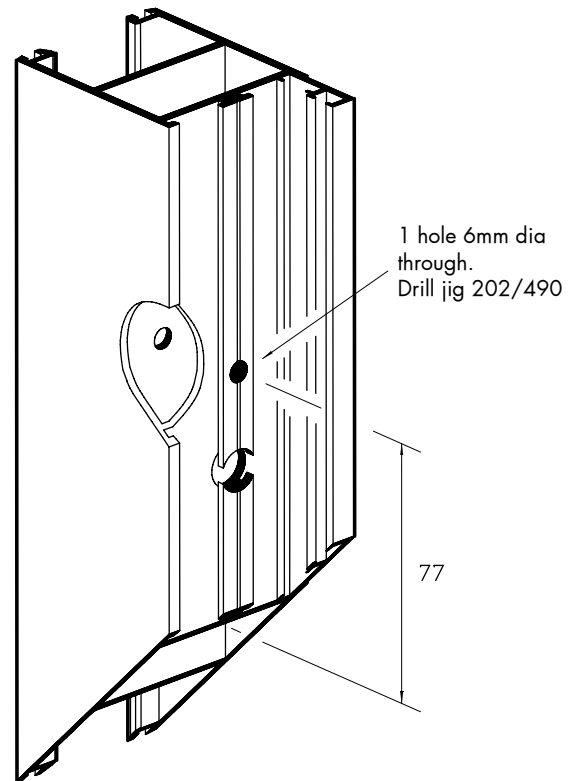

2 holes 10.2 dia through

modified

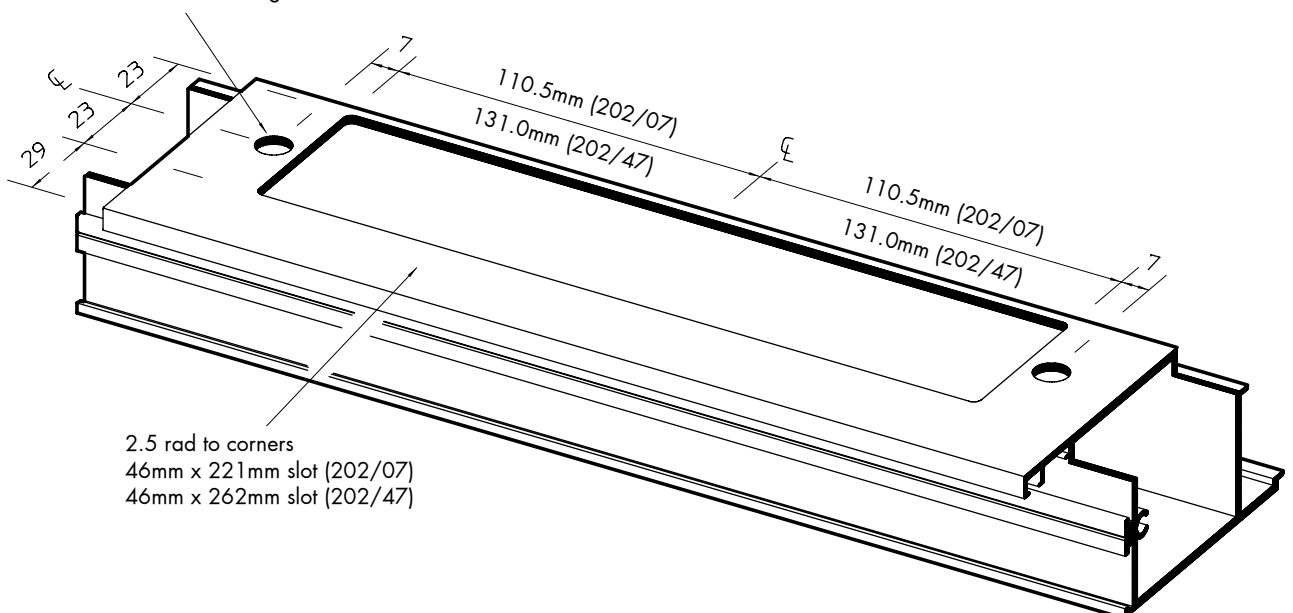

2.5 rad to corners
46mm x 221mm slot (202/07)
46mm x 262mm slot (202/47)

Machining Door Leaf

Door Pad Handle Fixing

For slave stile handle fixing holes prepare the same as lock stile.

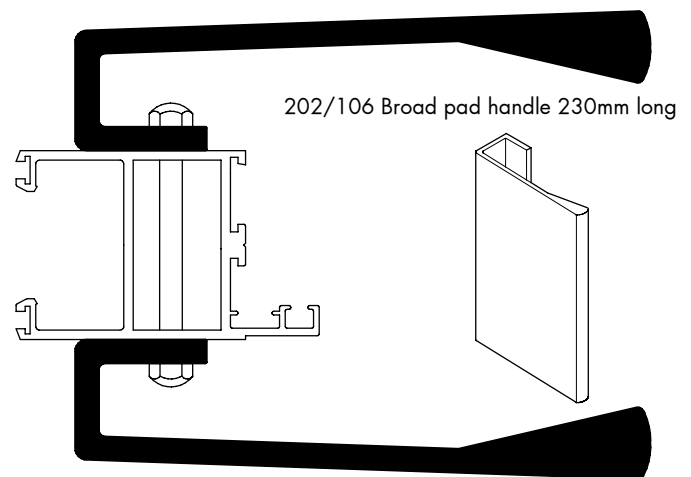
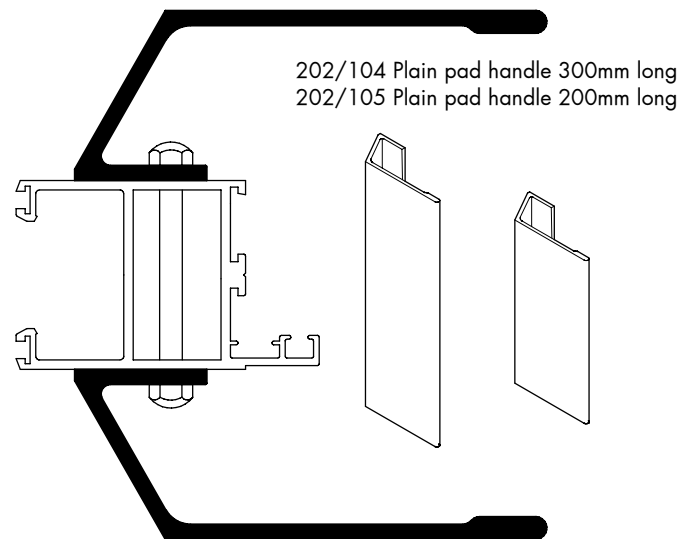
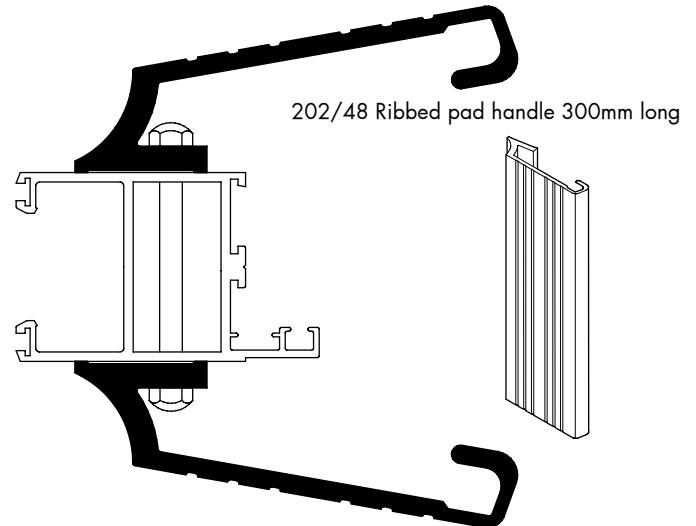
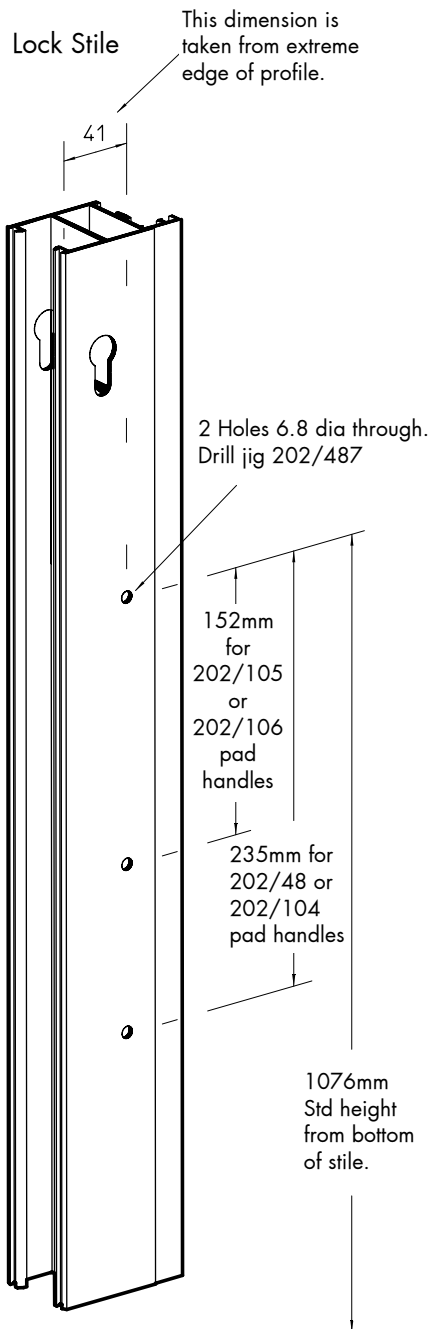

Machining Door Leaf

Door Tube Handle Fixing

The 202/107 handle length is set for the standard door leaf size of 2137mm high. If the door leaf is smaller than 2137mm then reduce the handle height by the difference between actual and standard height. For higher than standard doors special size handles are required (contact sales).

Note:- On rebated open in doors fitted with 202/107 handles, the weather bar (2816) must be butt jointed both sides of the handle bracket as shown. This condition does not apply to open out rebate doors as the weather bar will run continuously under the handle bracket.

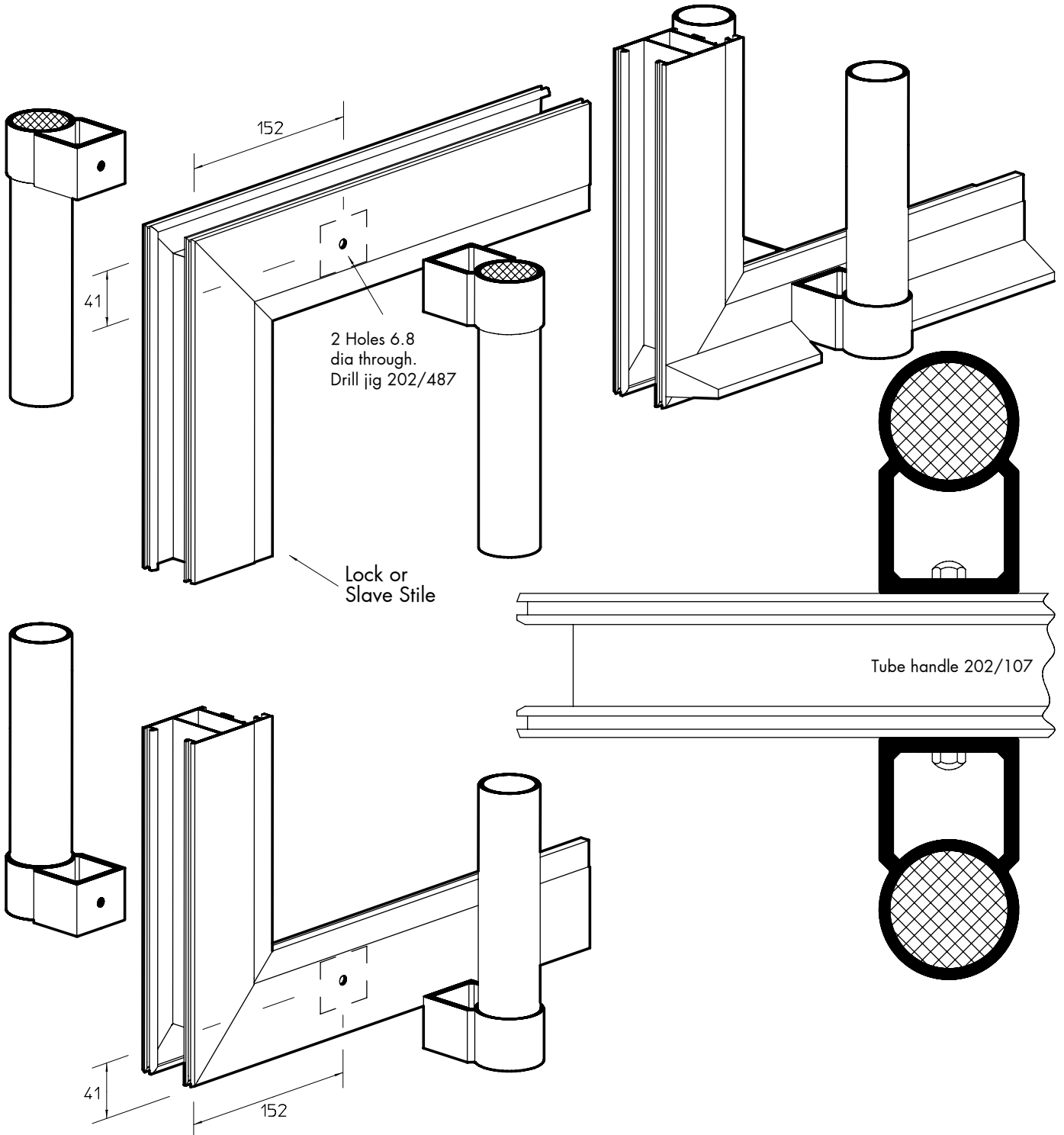

Machining Door Leaf

Special machining for Adams Rite exit device

Preparation shown for L/H open out door, mirror preparation for R/H open out door.

On double doors prepare slave stile as lock stile but opposite hand.

Prepare hang stile clip cover and top and bottom rails as standard plus additional machining as shown. Jig 202/494

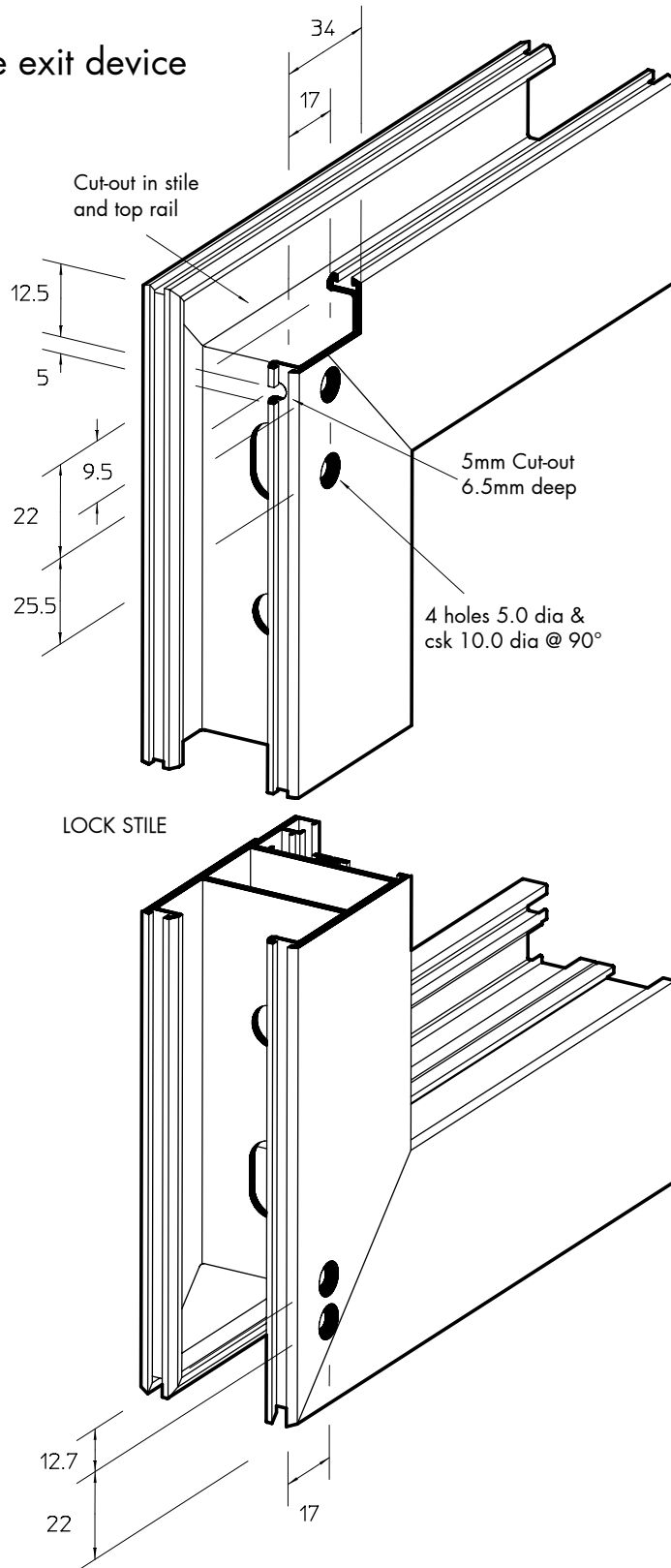
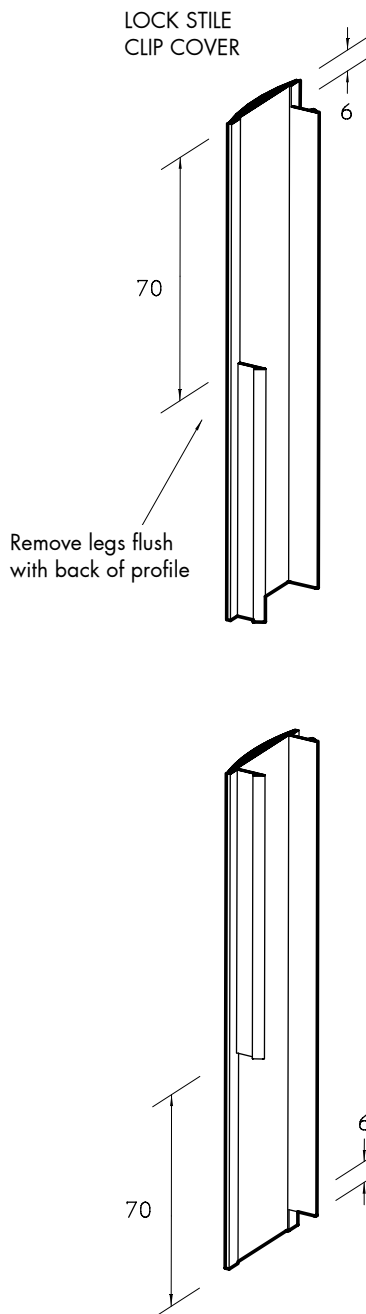

All dimensions are taken from the extreme edge of the profile

Machining Door Leaf

Special machining for Adams Rite exit device (cont)

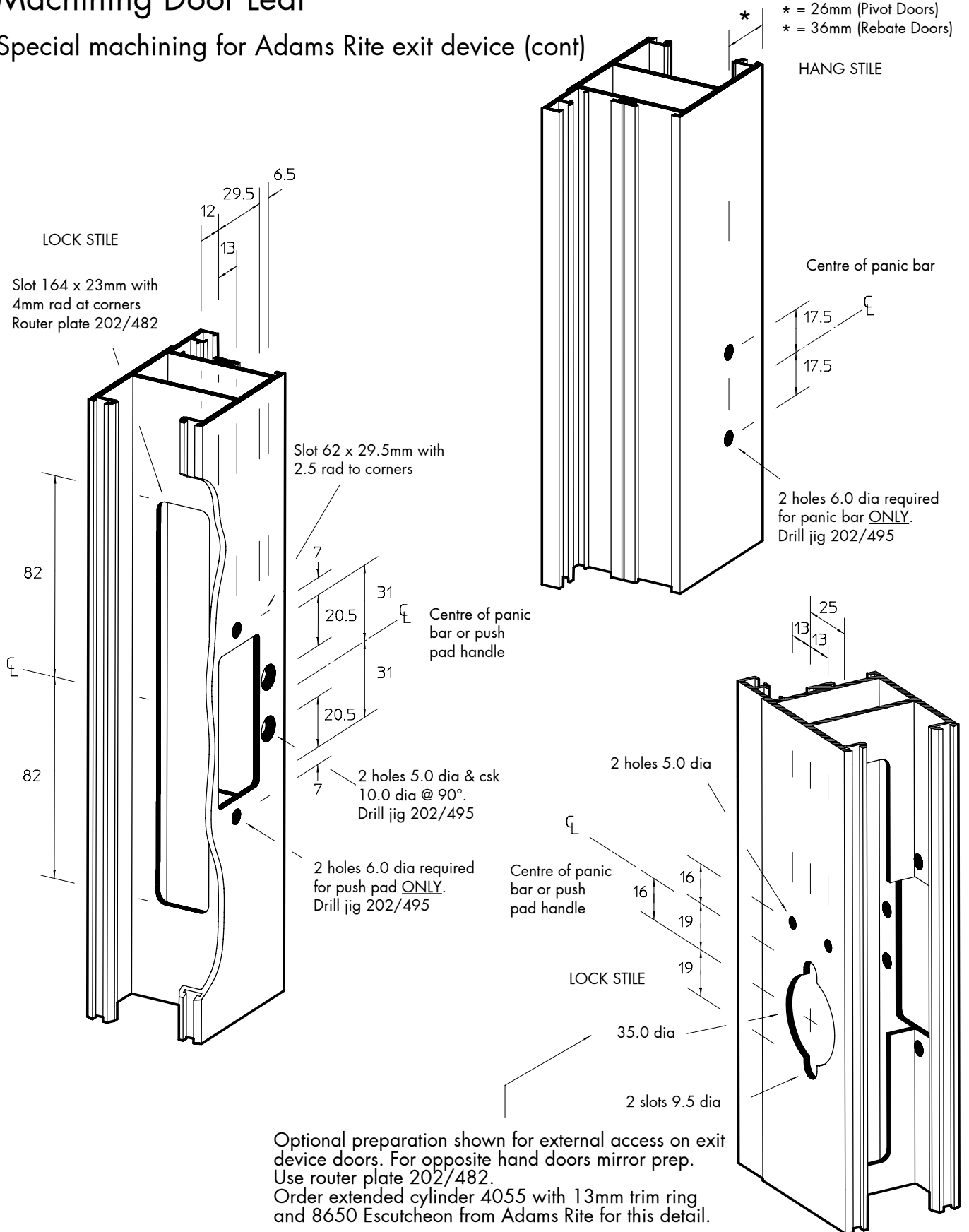

Optional preparation shown for external access on exit device doors. For opposite hand doors mirror prep. Use router plate 202/482. Order extended cylinder 4055 with 13mm trim ring and 8650 Escutcheon from Adams Rite for this detail.

Machining Door Leaf

Muntin Bar (276,277 & 278)

Cruciform and 'T' Joint Preparation.

At the point where vertical muntin bars meet horizontal muntin bars the machining shown below should be carried out in the horizontal bar at the centre line of the joint.

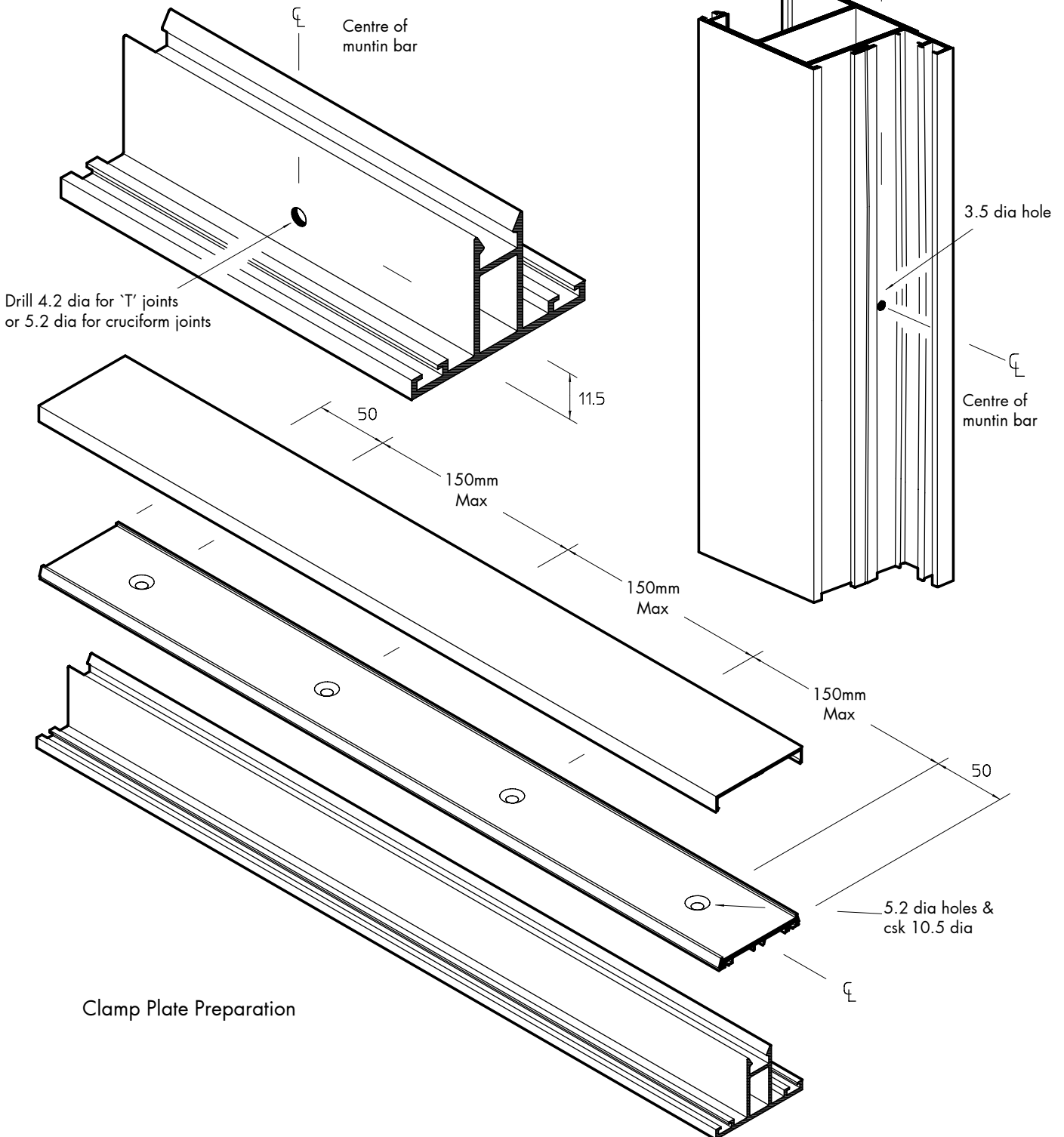

Machining Outer Frame

Rebate Adaptor (2820 or 2821)

Rebate door adaptor 2820 fits into 16mm pocket frame and adaptor 2821 fits into 32mm pocket frame at the head/transom and jambs.

NOTE:- Head/transom adaptors are not required for rebate doors with head closer.

CUTTING SIZES

Width = O/A door opening width
Height = O/A door opening height

(*) Cut back required on lock jamb adaptor only for clearance around armour strike (202/465) in jamb if fitted.

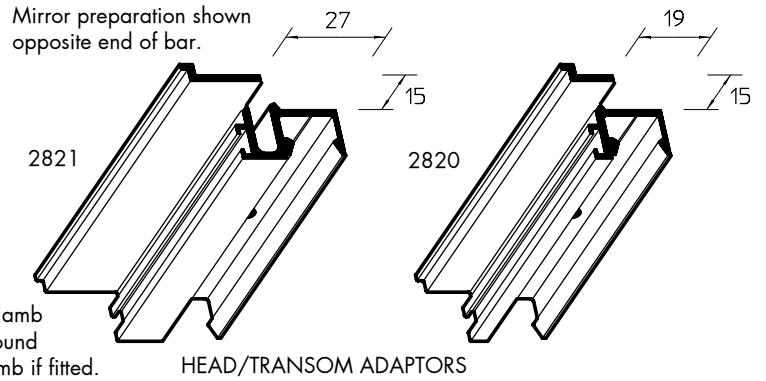

JAMB ADAPTORS FOR REBATE DOORS WITH HEAD CLOSER

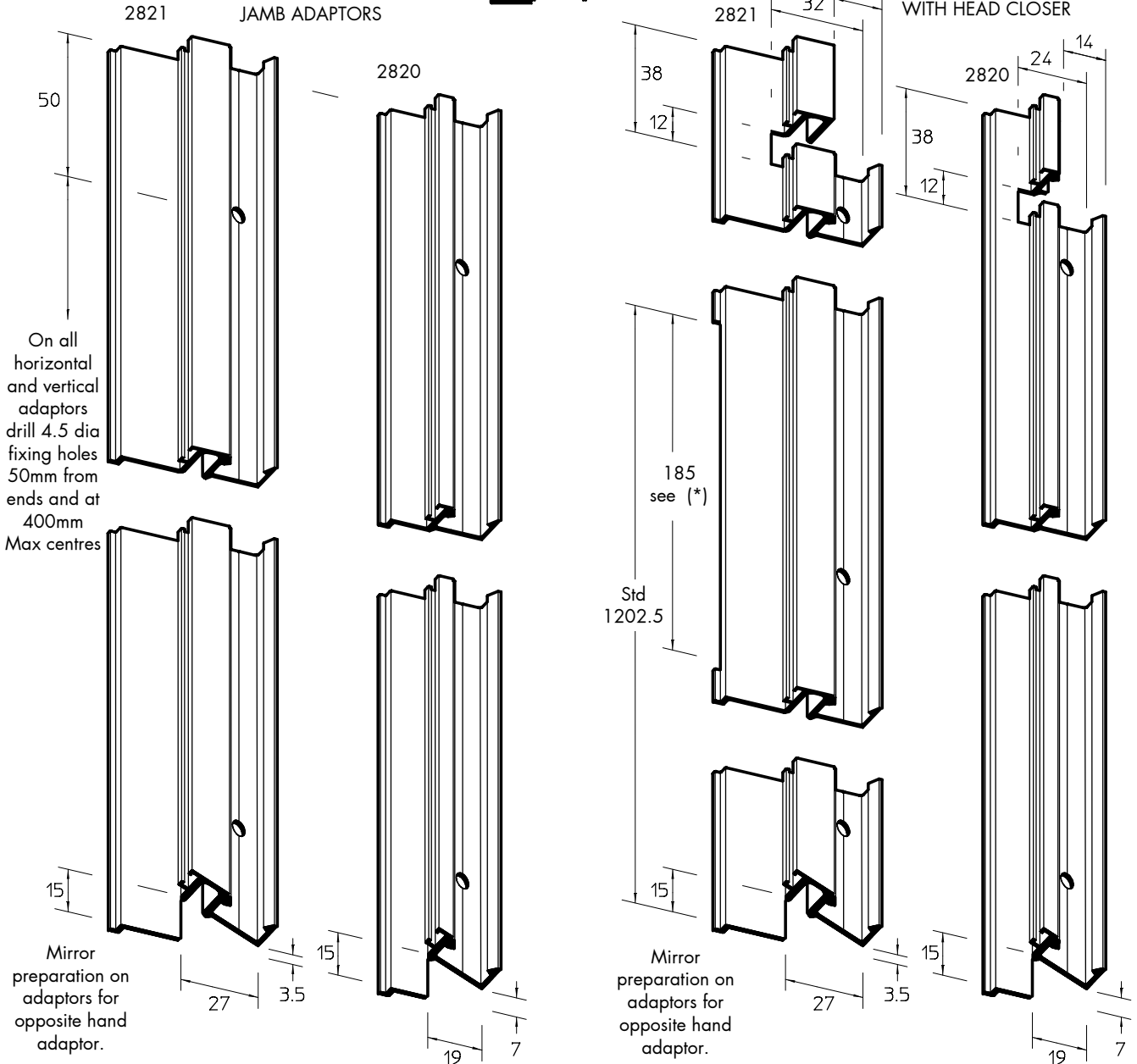

Machining Outer Frame

Head (2957) or Transom (2955) for Centre Pivot & Rebate Doors with Head Closer

For double doors repeat preparation opposite end of profile.

Drill jig 202/155.

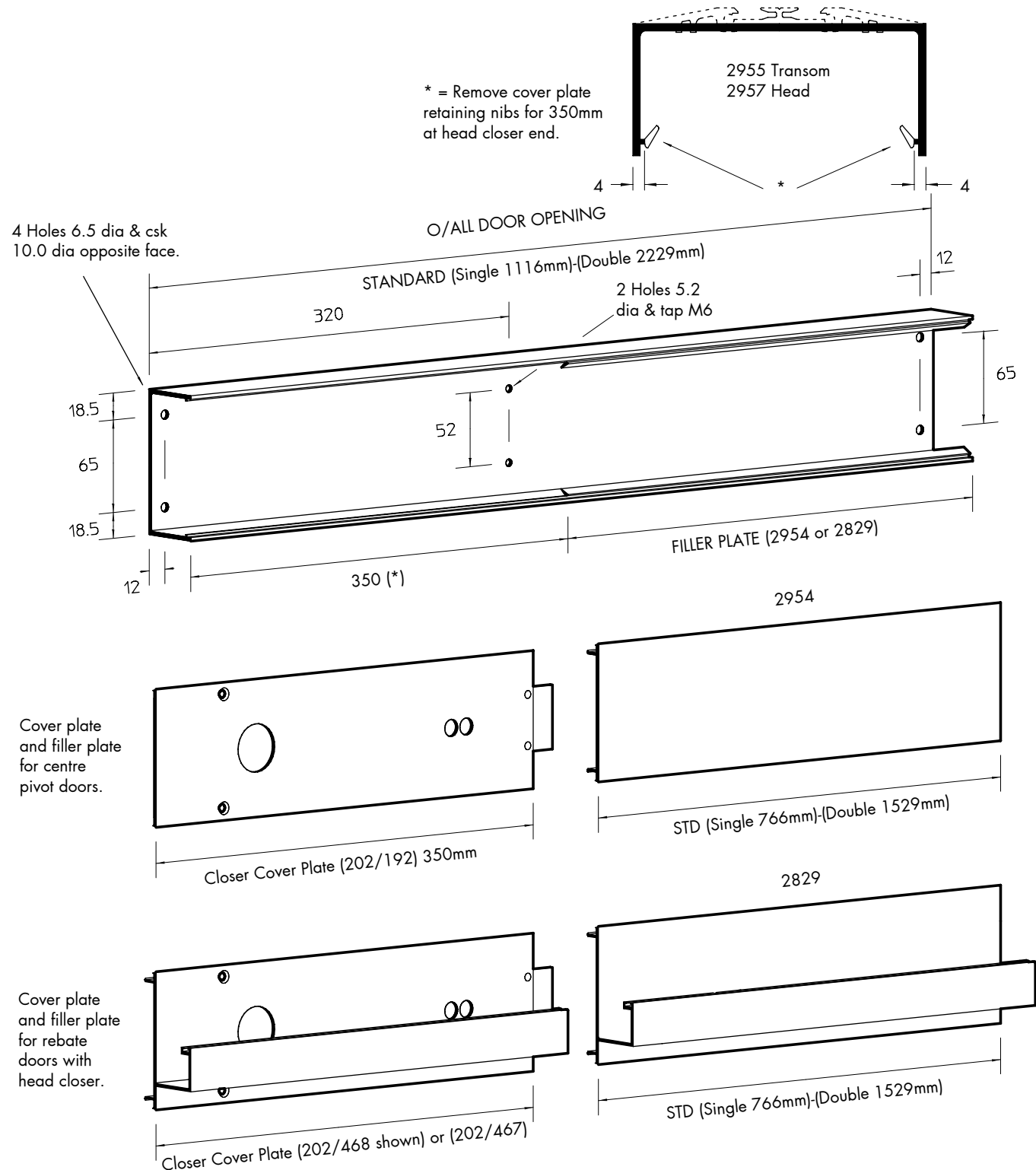

Machining Outer Frame

Head (2951 or 2981) or Transom (2952 or 2982) for Rebate Doors

Section 2951 shown

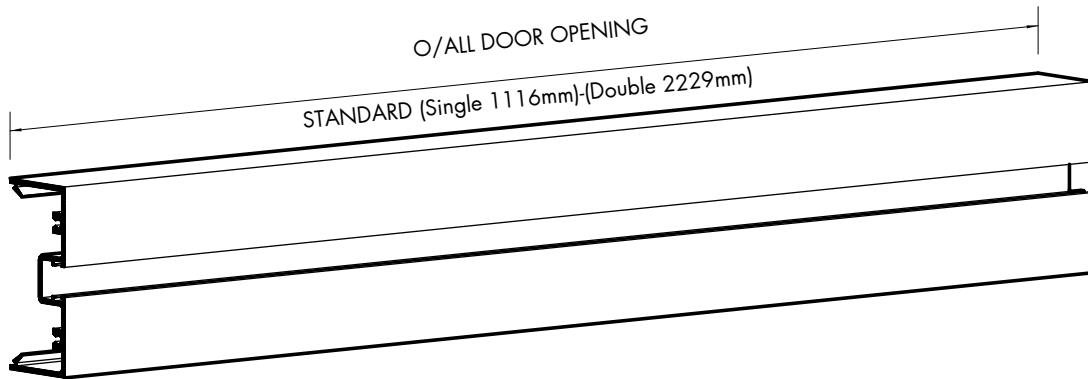

Typical 32mm pocket
Transom detail

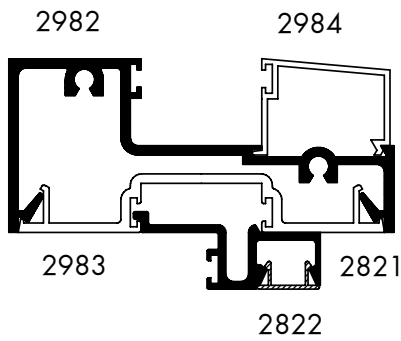

Typical 32mm pocket
Head detail

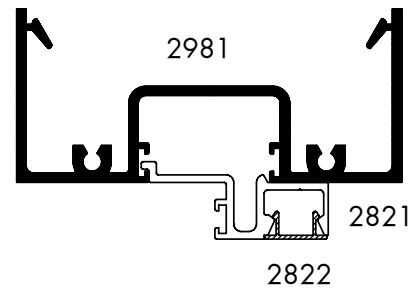

Typical 16mm pocket
Transom detail

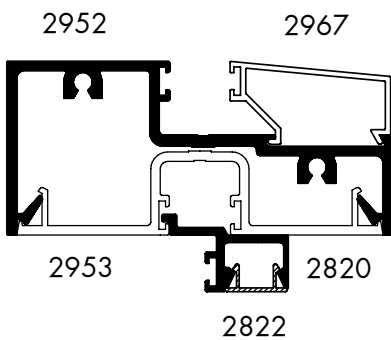

Typical 16mm pocket
Head detail

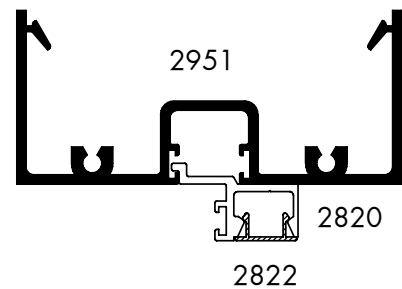

Machining Outer Frame

Hanging & Locking Jamb (2957) for Centre Pivot Doors

The 10mm allowance between the bottom of the jambs and the door opening is to allow the jambs to sit inside the sub cill.

Work size is taken from underside of sub cill.

Profile 2951 or 2981 **MUST** be used on Hanging Jambs when fitting Anti Finger Trap doors.

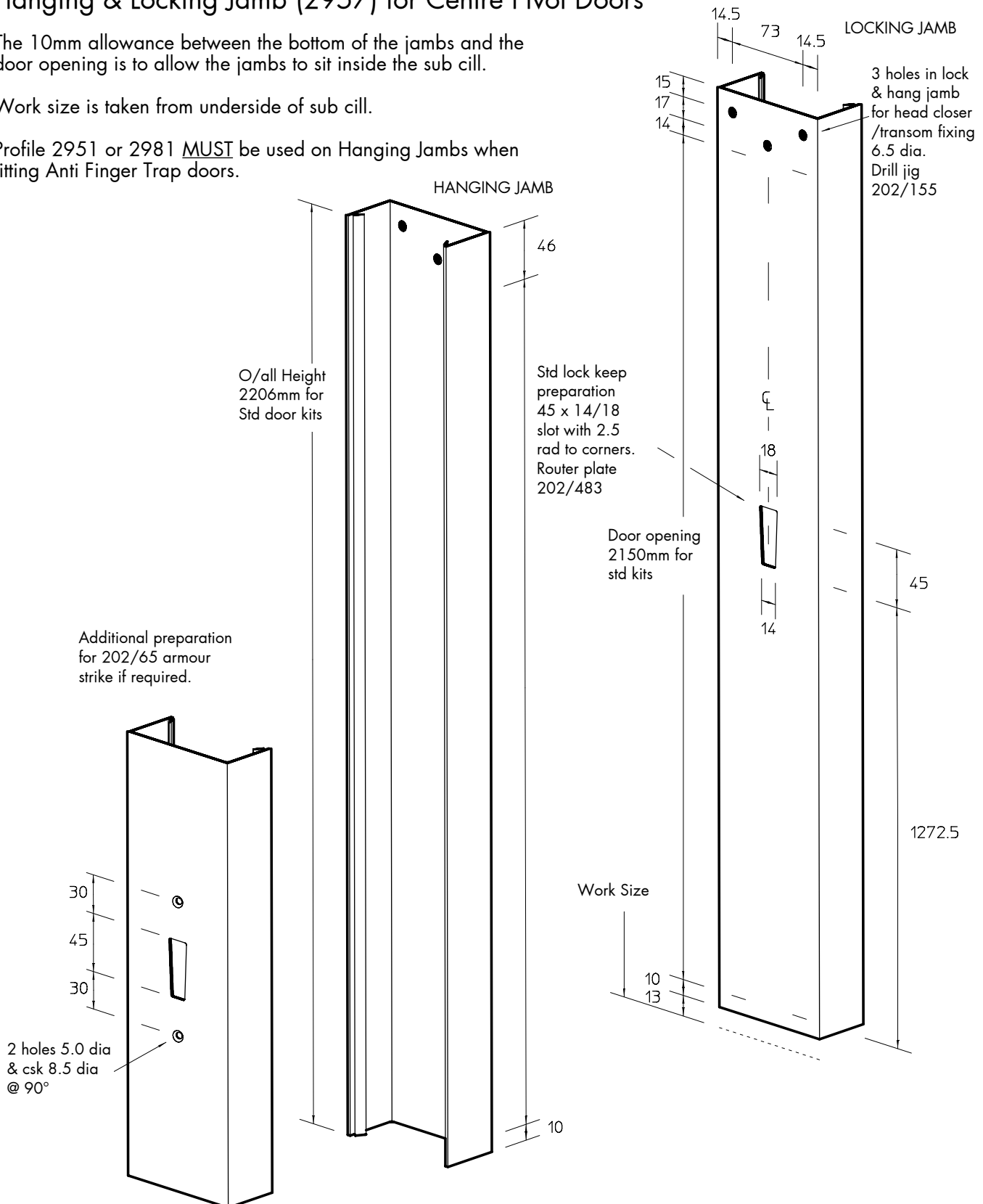

Machining Outer Frame

Hanging & Locking Jamb (2951 or 2981) for Rebated Doors

Handing of door must be determined before machining the jambs. L/H open out door or a R/H open in door shown.

The 10mm allowance between the bottom of the jambs and the door opening is to allow the jambs to sit inside the sub cill.
Work size is taken from underside of sub cill.

Typical section 2951 shown.

When a fixed light above the door is required, drill 2 holes 6.0 dia in lock & hanging jamb for transom fixing. Use drill jig 202/155

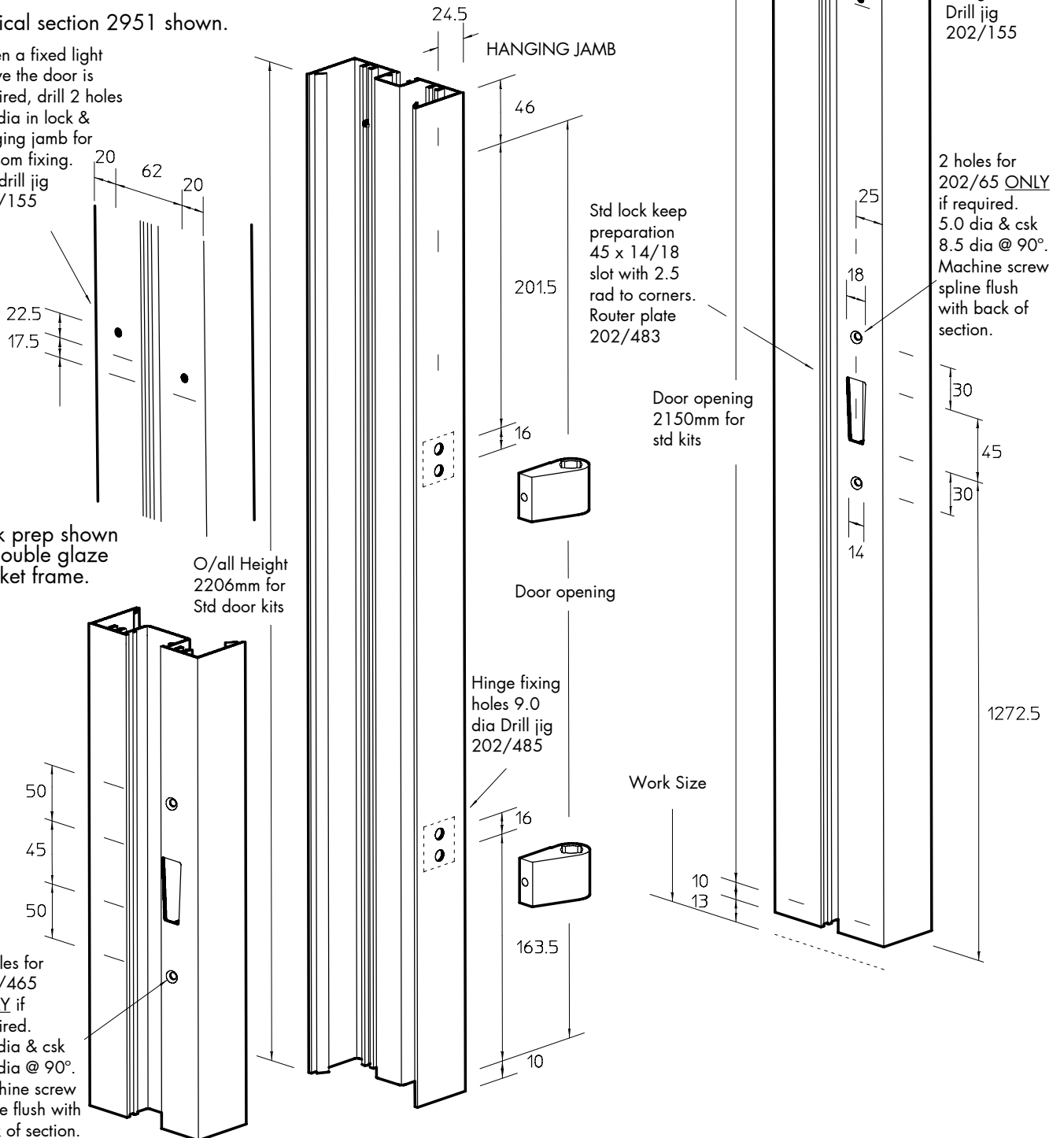

Machining Outer Frame

Centre Pivot Doors Anti Finger Trap Liner (2832)

This liner is used on centre pivot doors only, when Anti Finger Trap Stiles are to be used.

Profile 2951 or 2981 MUST be used on Hanging Jambes when fitting Anti Finger Trap doors.

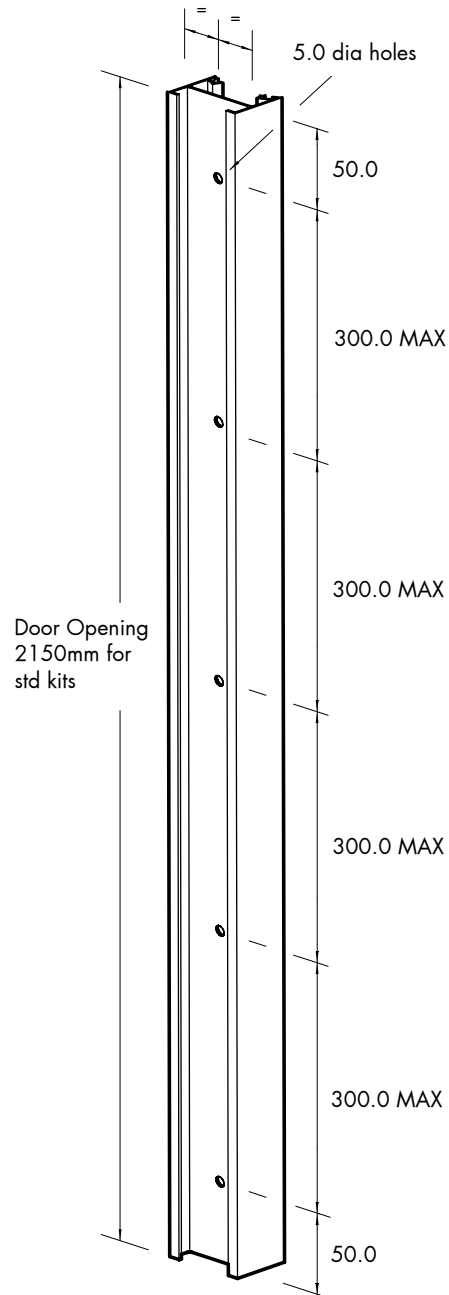

Machining Outer Frame

Threshold (2994 & 2817) for Centre Pivot Doors

* Threshold Grill Size (202/408) =

- Single door 1 off required - O/A door opening minus 100 (Cut from blank end)
- Double door 2 off required - O/A door opening minus 300 divide by 2 (Cut from hole end)

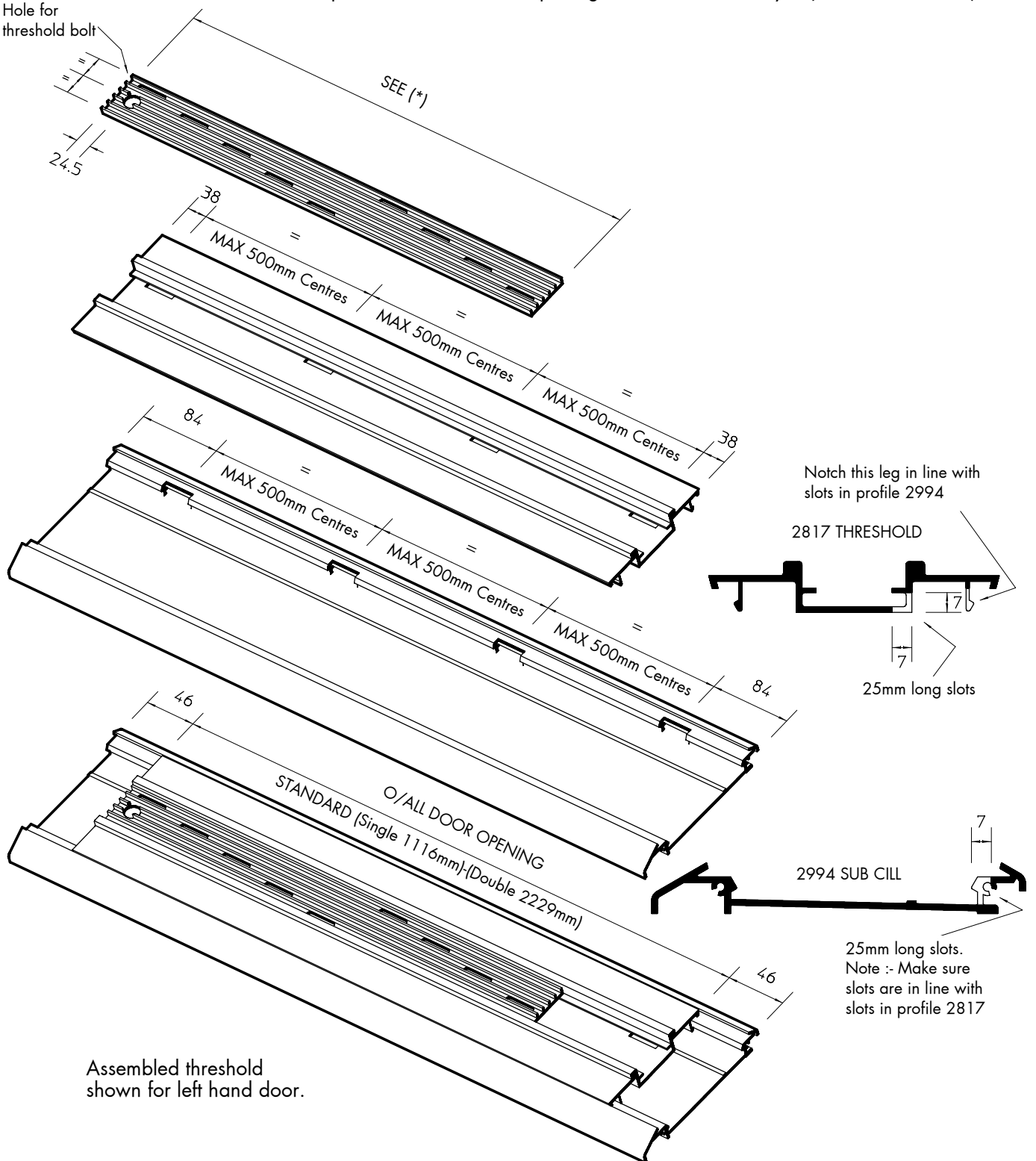

Machining Outer Frame

Threshold (2994 & 2819) for Rebate Doors

* Threshold Grill Size (202/530) & (202/531) =

Single door 1 off 202/530 or 202/531 - O/A door opening (Cut from blank end)

Double door 1 off 202/530 & 1 off 202/531 - O/A door opening minus 100 divide by 2 (Cut from hole end)

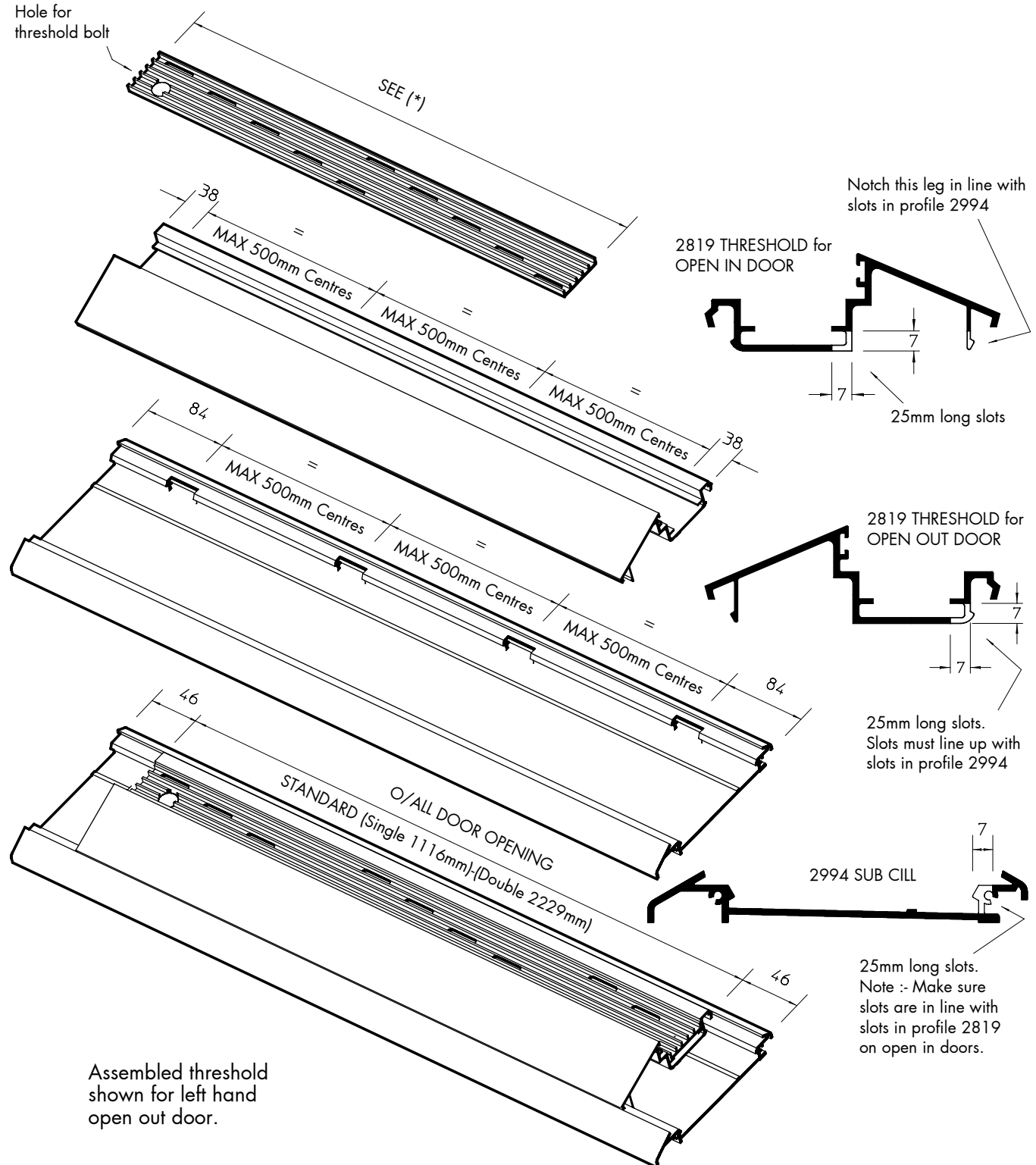

Assembly

Door Leaf

The door leaf consists of 2 stiles and 2 rails (using profile 2810) which are jointed using corner cleats 202/430 with a two part adhesive and corner ties 202/445. The stiles are closed off with clip cover 2811 and or slave stile adapter 2827. Optional 150mm mid rail 2823 or 160mm bottom rail adapter 2826 or muntin bar 276, 277 & 278 can also be fitted after assembly.

Before assembly determine handing of door noting that the beading is always on the inside of the door. Lay out profiles in order of assembly on work top.

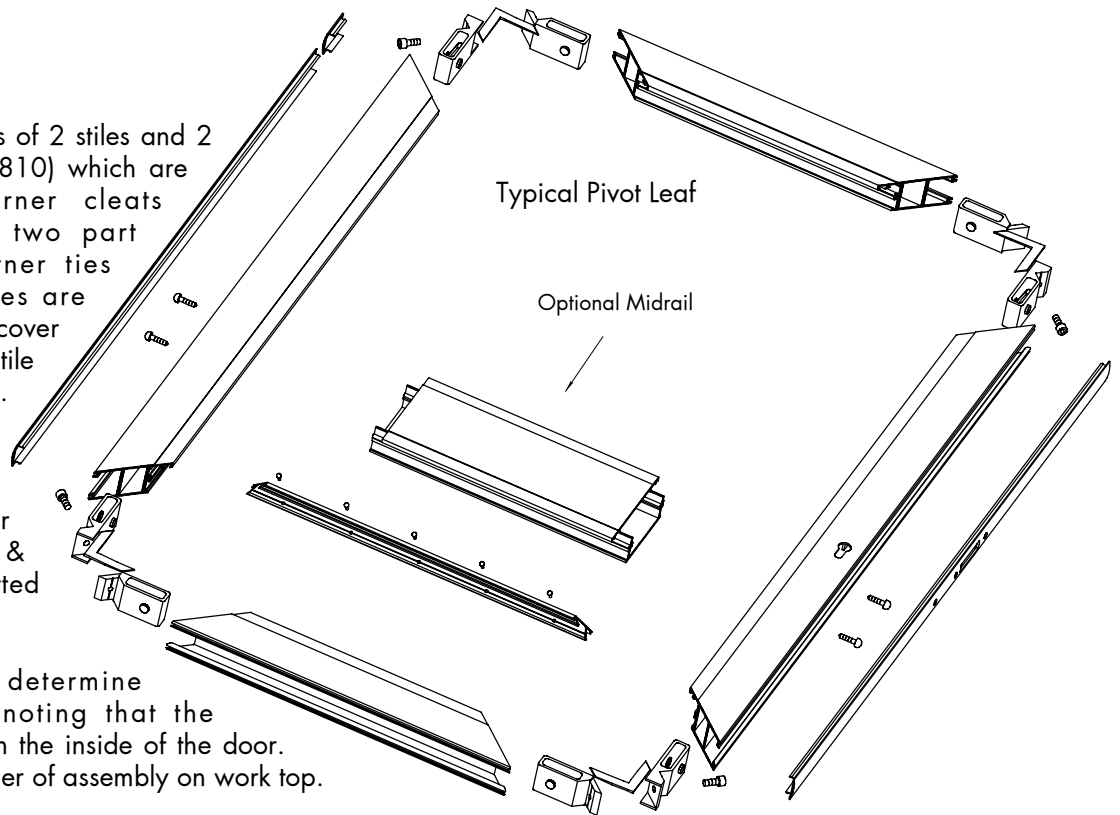

CENTRE PIVOT

Apply inner seal 105/184 into inner, and 105/37 woolpile into the outer weatherseal grooves, in the top and bottom rails. 105/37 is to run full length of rails, plus fed into the next stile by 25mm. 105/184 is to run full length of rails plus an overlap of 17mm (8.5mm each end), taking care not to stretch.

See detail page 5-8

DO NOT INSERT SEALS INTO STILES AT THIS STAGE.

REBATE DOOR

Apply 105/39 groove trim into outer weatherseal groove in the top rail on open-out doors or into inner groove on open-in doors, taking care not to stretch. Mitre cut at 45° to rail length.

DO NOT INSERT SEALS INTO STILES AT THIS STAGE.

Fit hinge 202/528 by sliding down the hinge tapping plate into stile hollow before corner jointing, making sure that the offset holes in the hinge tapping plate correctly align with the fixing holes in the hang stile. Screw hinge retaining screws into tapping plate then position door leaf hinge half over hinge retaining screws and tap home locking pin fully into the end of the hinge.

NOTE THAT THE HINGE CANNOT BE REMOVED ONCE FITTED THEREFORE CORRECT ALIGNMENT AND HANDING MUST BE ASCERTAINED BEFORE FITTING.

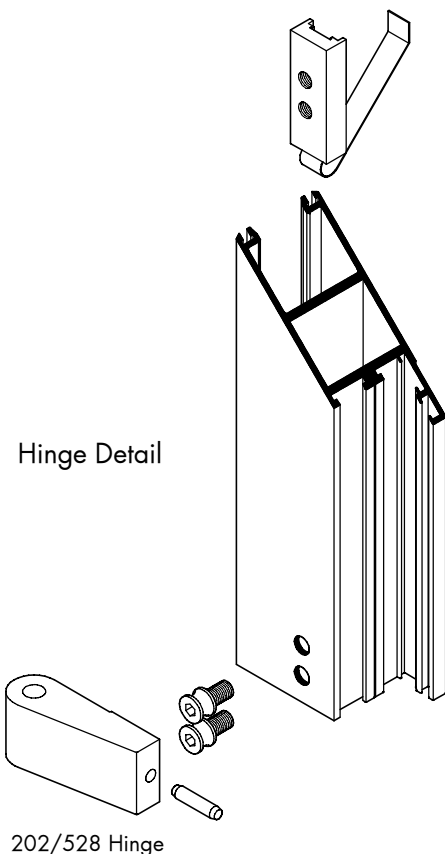

Assembly

Door Leaf (cont)

GENERAL

Apply a two part adhesive to corner cleats and inside profiles, then slide the correct corner cleat halves into respective profiles making sure that the spring buttons in the corner cleat locate fully into the holes in the profile.

Suggested adhesives:-

Araldite 2004 (hand mix)

3M EPX DP 190 (applicator mix)

Apply small joint sealant (Tremco or equivalent) to mitred ends of profiles to form a watertight joint to the corners. Slide corner ties 202/445 into profiles screwing corner joints together using Tuf lok M8 x 20 socket cap head screws in corner cleats. Clean off any excess sealant.

If fitting a mid rail (2823), apply small joint sealant to contact surfaces at the ends of the mid rail, leaving the recesses in profile 2810 clear for drainage. Position the mid rail between stiles and secure with 4 off No 12 x 1" pan head self-tapping screws through the stiles, cleaning off any excess sealant.

If fitting a bottom rail adapter (2826), remove outer half of letter plate if fitted, then apply small joint sealant to contact surfaces at the ends and bottom of the adapter, leaving the recesses in profile 2810 clear for drainage. Position the adapter between the stiles and secure with 2 off No 12 x 2" pan head self tapping screws through the stiles, cleaning off any excess sealant, refitting outer half of letter plate.

Corner Cleat Joint Detail

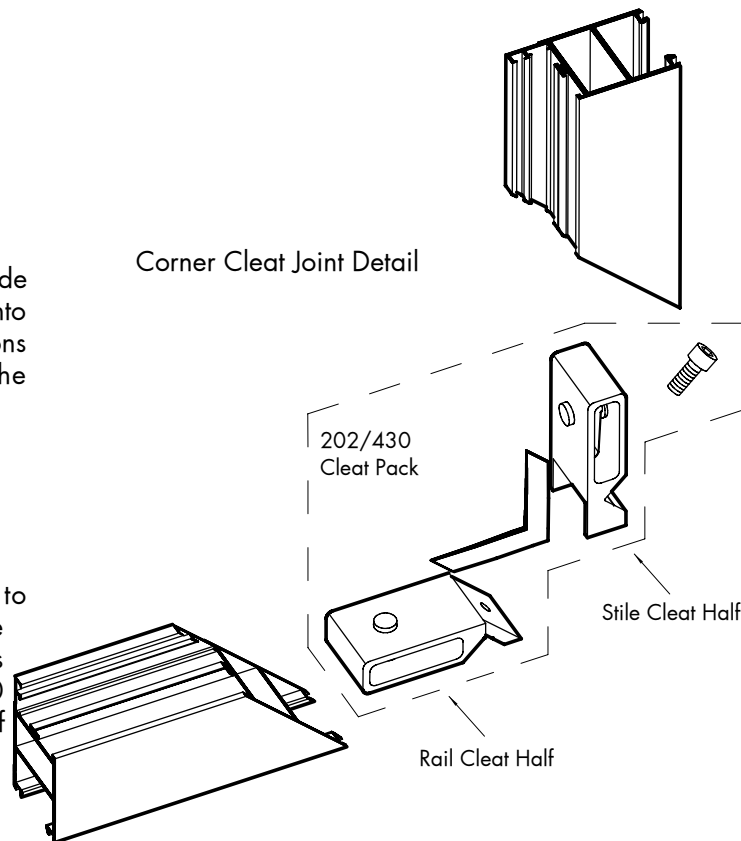

Mid Rail Joint Detail

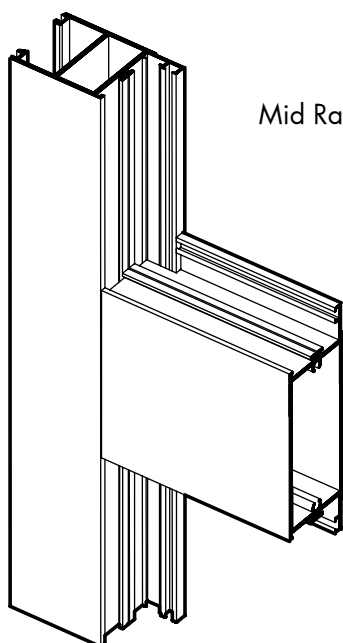

Bottom Rail Adaptor Joint Detail

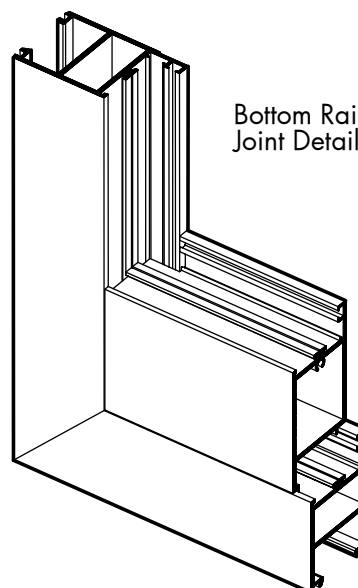

Assembly Door Leaf (cont)

GENERAL

For muntin bar assembly, first assemble any 'T' or cruciform joints in the muntin bar using joint moulding 318/40 and No 10 x 1.1/2" csk head self tapping screw for 'T' joints, or M5 x 45mm csk machine screw and a 318/68 pillar nut for cruciform joints. Assemble the joint moulding 318/40 and muntin bar, then drill a 3.6mm dia hole through the moulding into the muntin bar as shown below. Open up the web of the moulding only to 9.0mm dia. Fix moulding into muntin using No 8 x 5/8" csk blunt end self tapping screw. All joints should be sealed with 'Tremco' (or equivalent) small joint sealant.

For muntin to door leaf assembly, the muntin to frame moulding 202/452 should be fixed to the frame using a No 8 x 1/2" csk head self tapping screw. Joint mouldings 318/40 should now be fitted to the ends of each muntin bar. Drill a 3.6mm dia hole through the moulding into the muntin bar as shown below, fix into place using No 8 x 5/8" csk blunt end self tapping screw. The muntin bar profile 276 should now be fitted into the frame by sliding the joint moulding on the end of each bar into the frame moulding as shown then secure into place with a No 8 x 5/8 csk blunt end self tapping screw. Use 'Tremco' small joint sealant (or equivalent) on all joints.

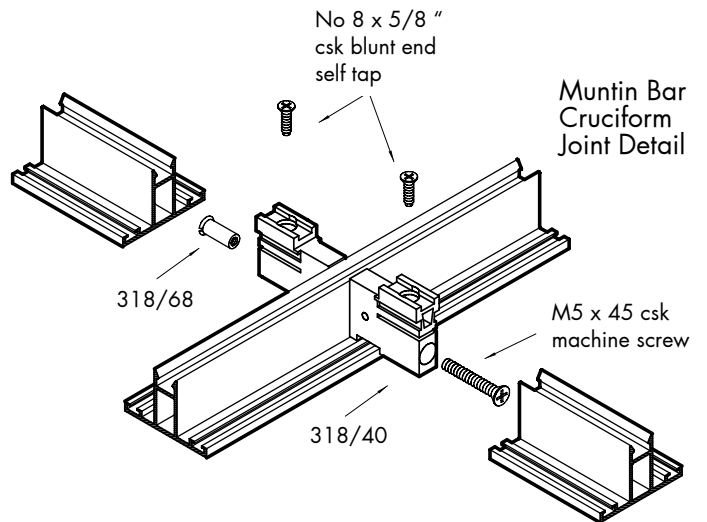
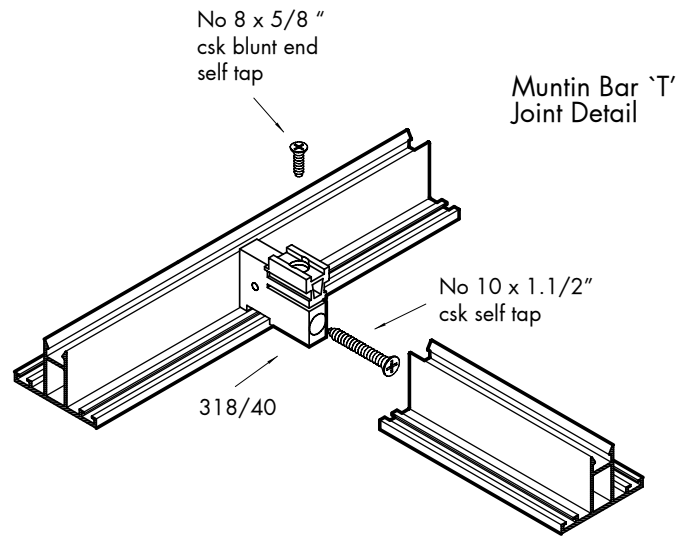

Fit onto end of muntin bar.
Drill 3.6 dia hole into moulding and muntin bar then open up top surface to 9.0 dia.

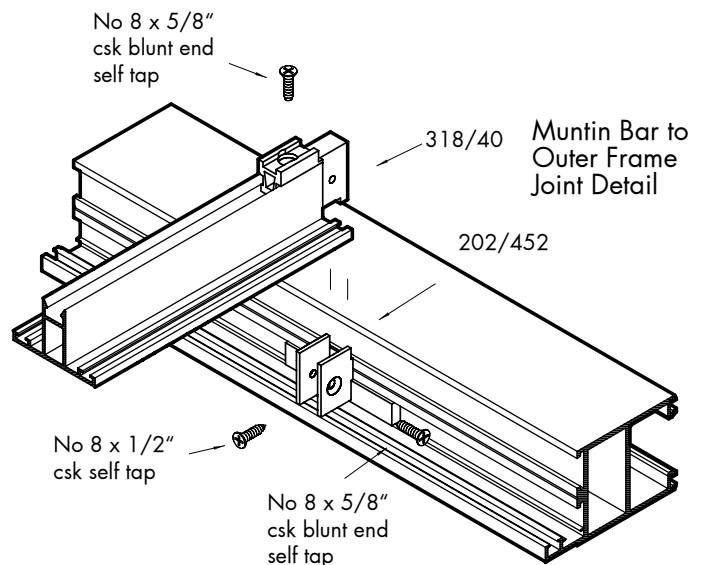
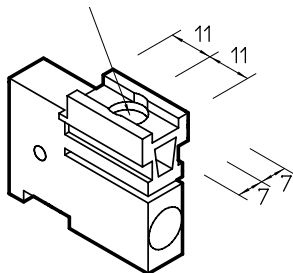

Assembly

Door Leaf (cont)

GENERAL

If not already fitted, fit lock 202/11 by first attaching 202/505 threshold bolt to lock. Slide attachment pin through mounting bracket and slot nearest latch in lock, then fit circlip to end of pin. Attach spring to lock and mounting bracket. Screw bolt to mounting bracket, cutting to required length.

Fit lock to stile using 2 off 202/444 pillars and 2 off No. 10 x 1.1/2" csk self tapping screws.

Slide lock cylinder 204/28 (or 204/33) into position through keyhole and secure with M5 x 35mm csk machine screw through face of lock. Clip on lock stile clip cover (2811) then screw cover to lock using 3 off 8/32 UNC x 5/16" csk pozi machine screws.

Adjust length of threshold bolt by screwing bolt in or out so that the end of the bolt is in line with the bottom of the door leaf, with the lock unlocked. Slide bolt guide bracket onto the end of the bolt and secure to the lock stile clip cover with two machine screws supplied. Smear small gap sealant around the cylinder then fit cylinder escutcheon 204/30.

If not already fitted, fit 202/14 flush bolts top and bottom of the slave stile clip cover 2811 (centre pivot) or slave stile adapter 2827 (rebated doors), using 2 off 202/515 flush bolt guide brackets and 8 off M5 x 10 machine screws.

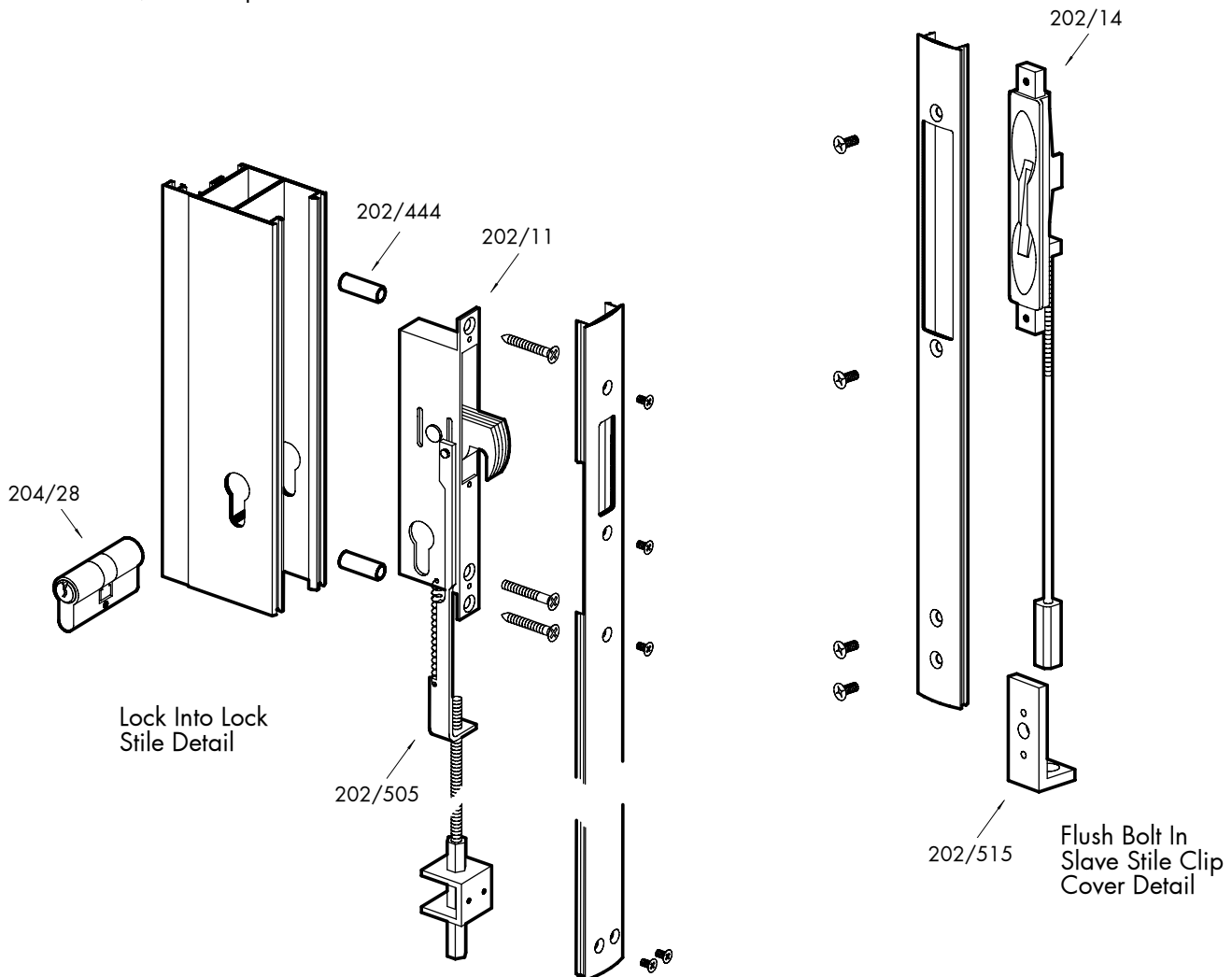

Assembly Door Leaf (cont)

GENERAL

On slave stiles insert 202/465 armour strike by tilting sideways into the slave stile taking care to observe handing. Clip in slave stile clip cover 2811 (centre pivot) or slave stile adapter 2827 (rebate doors), again observing handing. Align armour strike with cut-out in adapter, and screw adapter to armour strike using 2 off M5 x 10 csk head machine screws.

NOTE 202/465 ARMOUR STRIKE MUST BE FITTED ON ALL DOUBLE DOORS FOR SECURITY.

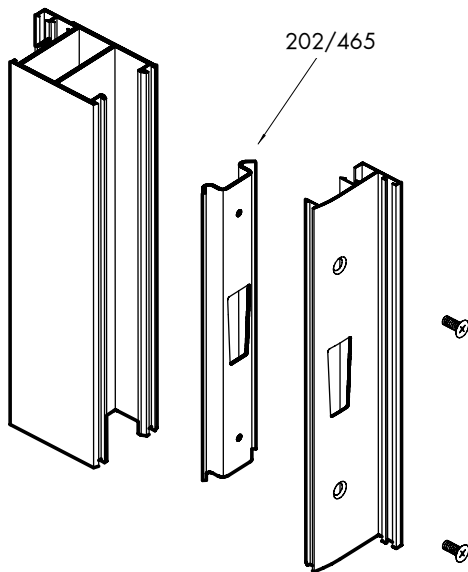

Slave Stile Armour
Strike Detail

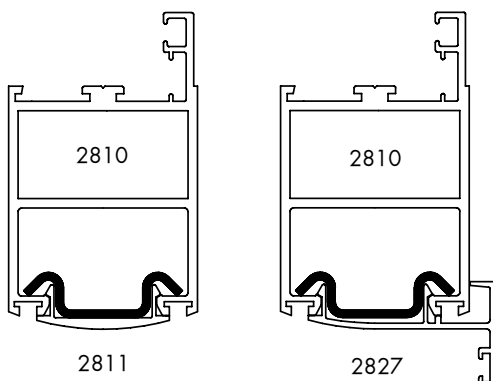

Assembly Door Leaf (cont)

CENTRE PIVOT

Prior to fitting closer arm 202/202 and floor pivot shoe, drill 4.8mm hole through pilot holes in the top and bottom rails into corner cleats. Fit 3 off M6 nutserts to top rail and 1 off M6 nutsert to bottom rail. Fit top arm onto top rail using 3 off M6 x 16 csk head machine screws and 1 off No 12 x 1/2" csk self tapping screw. Fit floor pivot shoe onto the bottom rail using 1 off M6 x 20mm pan head machine screw and 2 off No 12 x 3/4" pan head self tapping screws.

CENTRE PIVOT WITH ANTI FINGER TRAP

Prior to fitting closer arm 202/204 and floor pivot shoe, drill 4.8mm hole through pilot holes in the top and bottom rails into corner cleats. Fit 3 off M6 nutserts to top rail. Position 202/81 arm packer onto top rail, then fit arm onto top rail using 3 off M6 x 16 csk head machine screws and 1 off No 12 x 1/2" csk self tapping screw. Fit floor pivot shoe onto the bottom rail using 2 off No 12 x 3/4" pan head self tapping screws. Drill additional 4.8mm hole using pivot shoe as a guide, centrally into cleat button, and secure with No 12 x 3/4" pan head self tapping screw.

Fit 202/441 clips to both sides of hanging stile as shown, using No 8 x 1/2" pan head screws. Apply two part adhesive to clips then clip on adapter profile, (if clip fit is lose slightly bend legs of adapter profile).

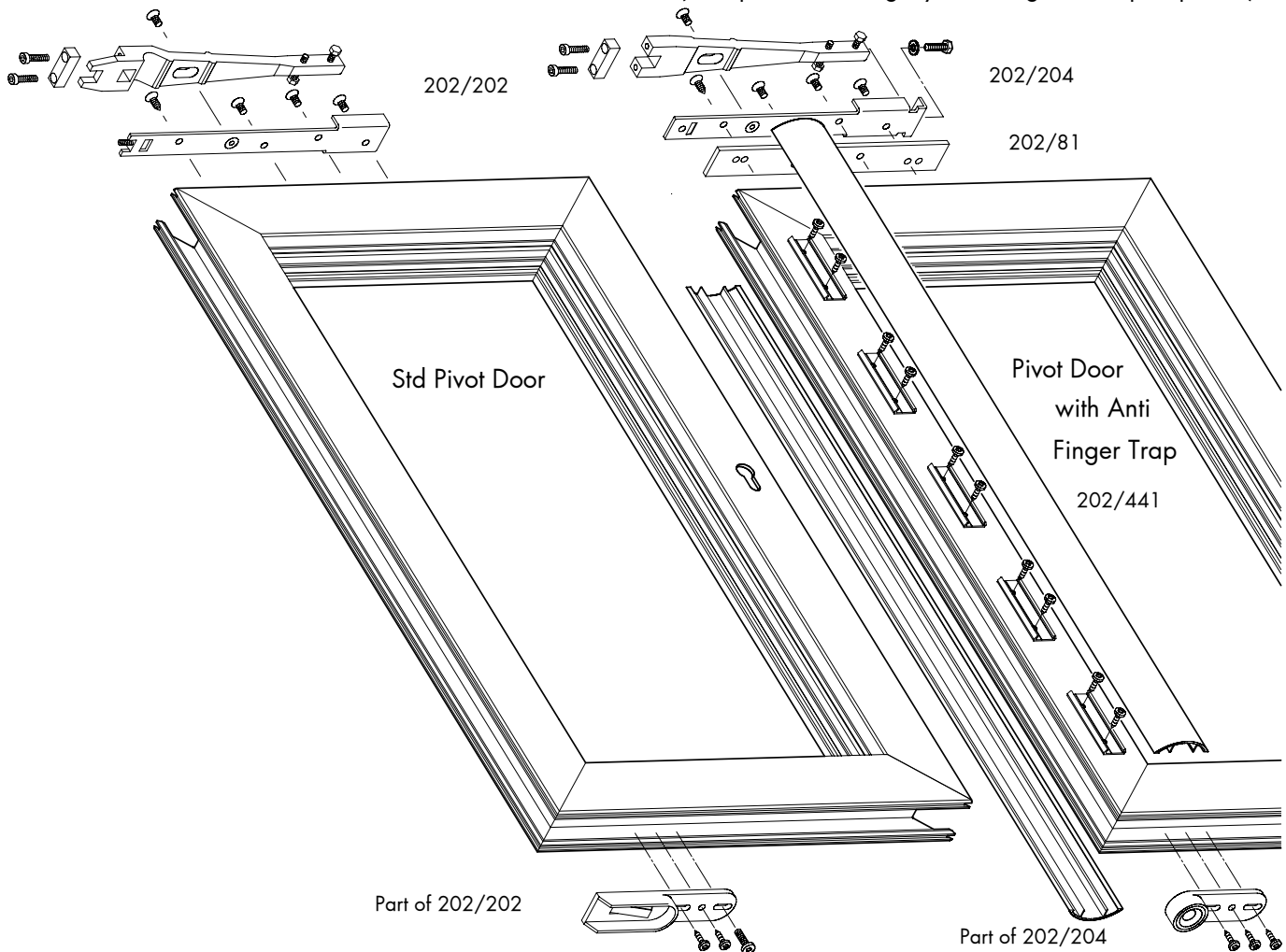

Assembly Door Leaf (cont)

REBATE DOOR WITH HEAD CLOSER

Before fitting the 202/469 closer arm slide rail, check handing of arm and if necessary rotate guide moulding and closer arm and reassemble (see detail below). Note that the offset hole in the guide moulding must be positioned so that the hole is closest to the machined away leg on the top rail, and the end moulding to be furthest from the hang stile. Fit 4 off M5 nutserts to the top rail. Position the 202/466 slide packer onto the top rail with the countersink holes face down, then fit arm slide onto the top rail using 4 off M5 x 16 csk head screws.

ALL REBATE DOORS

Clip on hanging stile clip cover 2811 onto the hanging stile. Slide 105/39 groove trim into both weatherpile grooves in stiles, taking care not to stretch trim. Mitre cut trim at top of door leaf to match trim in top of door leaf. If making double doors then slide 105/184 inner seal into rebate side groove of lock stile and fit 105/148 rebate weatherseal to the slave stile rebate adapter and trim off to length. Crimp weatherpile groove at ends of profiles to secure weatherpile and trim.

For further clarification refer to general arrangements.

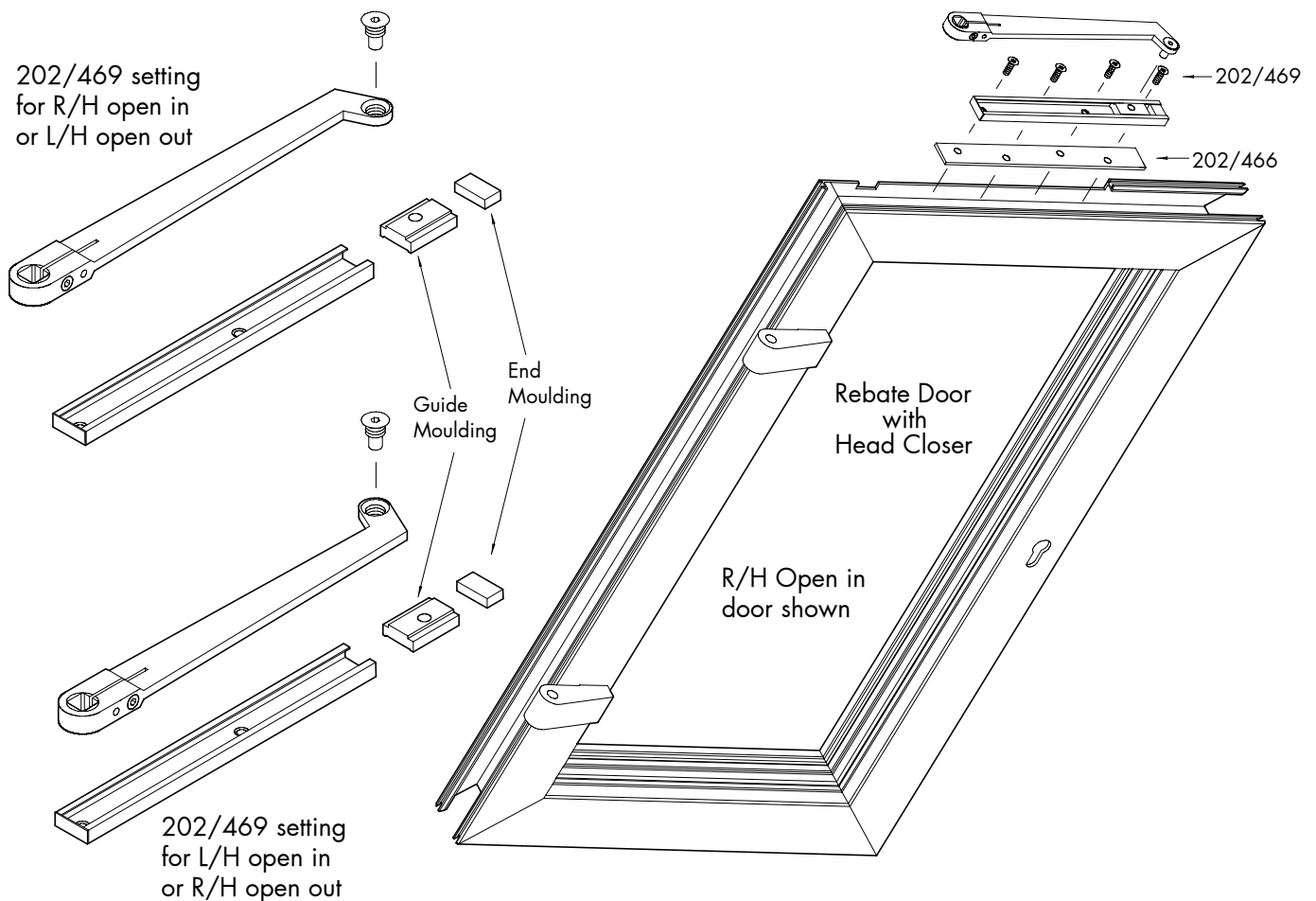

Assembly Door Leaf (cont)

CENTRE PIVOT

Clip on the hanging stile clip cover & end cap (end cap to be positioned at the top of hang stile). Slide 105/184 inner seal into stiles inner groove and overlap ends with the seals on the top and bottom rails, then insert 105/37 woolpile into outer stile groove and butt joint with woolpile in the top and bottom rails. For double doors slide 105/39 groove trim into slave stile. Crimp weatherpile grooves at ends of profiles to secure weatherpile and trim.

For further clarification refer to general arrangements.

GENERAL

Position the weather bar on the door leaf (see detail below), and using the weather bar as a template mark fixing holes and drill marked positions using 3.0mm drill. Apply small gap sealant to the back of the weather bar and then fix to door leaf using No 6 x 1/2" pan head self-tapping screws. Seal on end caps 202/462 and 202/463 to ends of weather bar.

Pad handles or tube handles can now be fitted to stiles using 202/52 fixing bolts and nuts. Apply small gap sealant to the back of the handle to seal around the fixing holes.

105/37
Joint Detail



Apply small joint sealant to these surfaces to prevent shrink back.

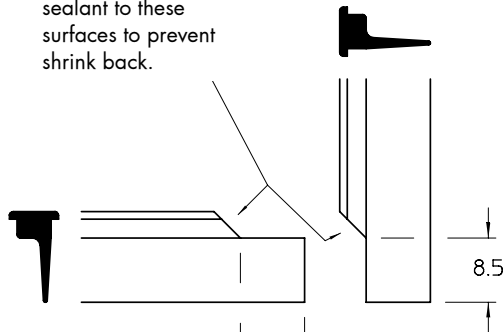

105/184
Overlap Detail

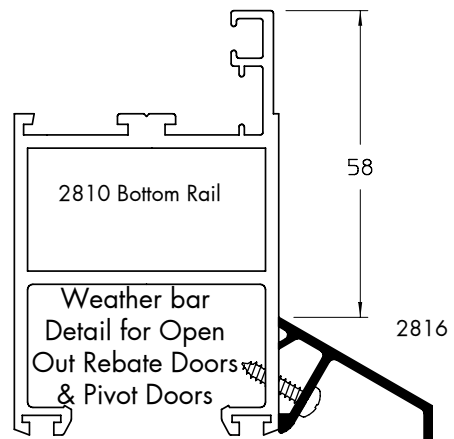
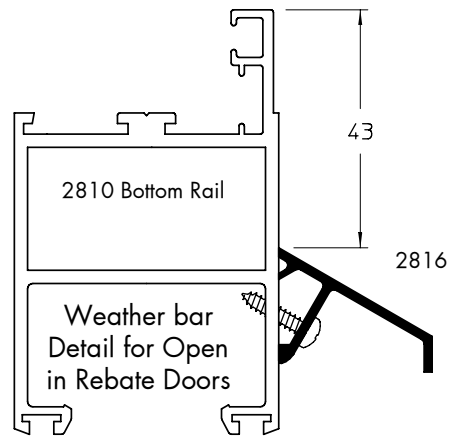

Assembly Door Leaf (cont)

EXIT DEVICES

Before installation of Adams Rite exit devices, secure fixing plate to the stile with screws supplied (see detail). Further assembly is as installation instructions supplied with the exit devices.

Note that the standard Adams Rite 8600 exit device cannot be used with this door, and special exit devices are required that are supplied with fixing plate as detailed below. (Refer to parts listed opposite)

Please note that parts handing is as viewed from outside eg,

L/H = Hang stile on left viewed from outside.

Exit Device Parts List (Door Leaf)

202/520	42" Push Bar
202/521	48" Push Bar
202/522	L/H Door Push Pad
202/523	R/H Door Push Pad
202/524	L/H Door Exit Device
202/525	R/H Door Exit Device

Parts required for external access on exit device doors.

A-R 8650	Escutcheon plate
A-R 4055	Extended cylinder with 13mm trim ring
A-R = Order from Adams Rite	

Exit Device Parts List (Frame)

202/436	Exit device cill locator (single pivot)
202/437	Exit device cill locator (double pivot)
202/535	Exit device cill locator (single rebate)

See page 5-13 for cill locator usage.

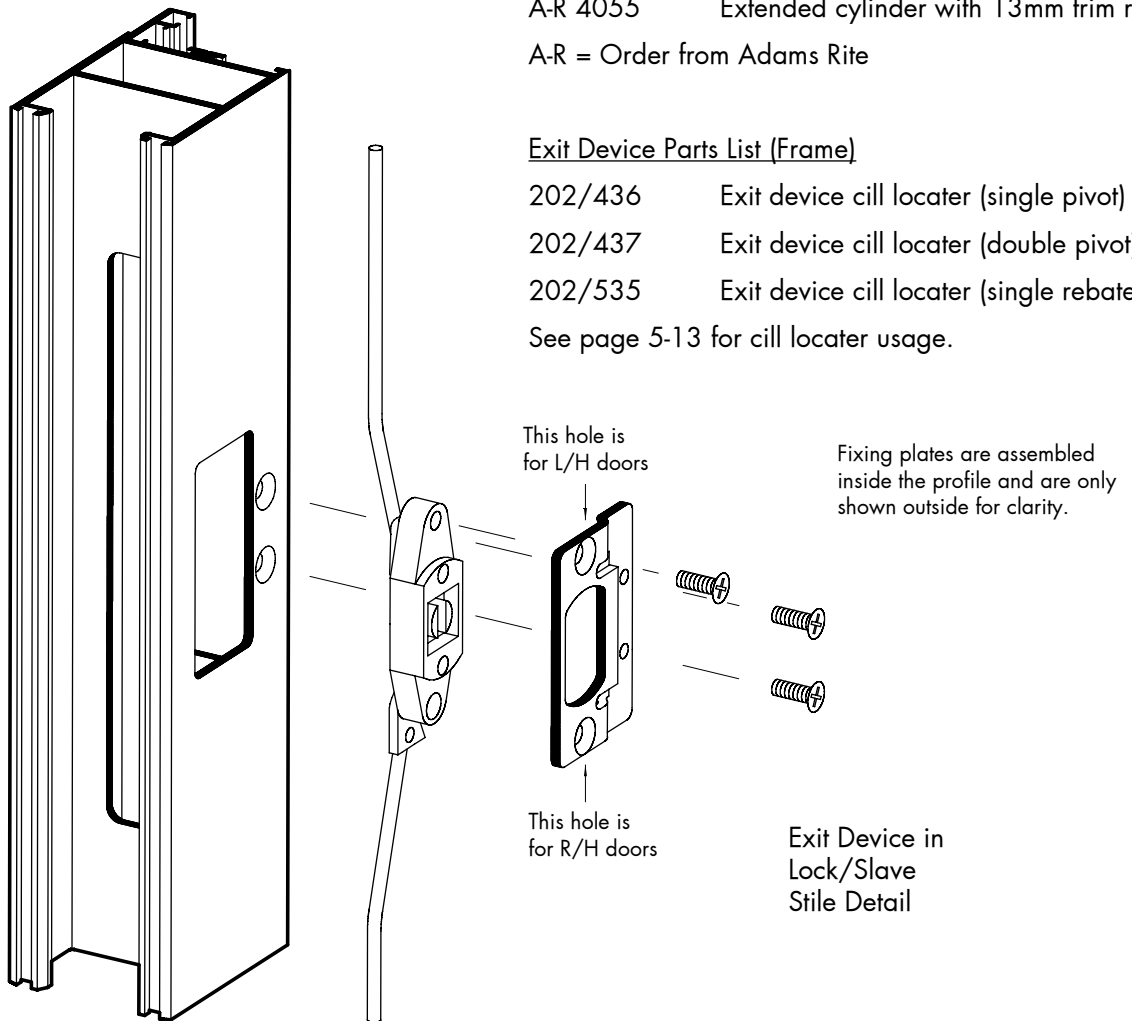

Assembly Framing

CENTRE PIVOT & ANTI FINGER TRAP

Secure transom bracket 202/97 to door frame jambs with 3 off M6 x 12 csk head machine screws and 3 off M6 serrated flange nuts. Apply small gap sealant to ends of head/transom, then screw head or transom to transom bracket with 2 off M6 x 12 csk head machine screws both ends.

Fit Dorma head closer in accordance with instruction leaflet supplied. Then clip in filler plate and secure 202/192 closer cover plate using two M5 x 35 csk machine screws.

On double doors the flushbolts and threshold bolt locate into the threshold by means of a cill flushbolt locator 202/421 and cill flushbolt locator fixing plate 202/422. Slide the fixing plate into the threshold channel then screw the flushbolt locator to the fixing plate with 2 off No 8 x 3/8" pan head self tapping screws, but before final tightening of screws, position the locator in the centre of the threshold – then tighten. Note that this component is handed and that the hole by the two fixing screws is for the flushbolt in the slave leaf, and the other hole for the threshold bolt in the locking leaf.

For single and double doors, insert threshold pivot supplied with closer arm into the threshold by sliding the 202/420 tapping plate into the threshold channel and positioning the pivot locator onto the threshold (std 202/419 or Anti 202/443). Screw pivot outer casing through pivot locator into tapping plate then making sure that the end of the locator is flush with the threshold, tighten in place. Note that the hole in the locator must be furthest from the end of threshold. Screw lock nut onto pivot then screw pivot into pivot outer casing and lock off with lock nut. The pivot height can be adjusted by unscrewing the pivot and locking into place with the lock nut.

On single doors, the threshold bolt locates into the pre drilled hole in the threshold grill 202/408. Position the grill into the threshold with the hole at the lock stile end. On double doors this hole is not required, and if necessary cut down grill from hole end. The grills may now be placed into the threshold. Grills are not fixed into place in order that they can be removed and the threshold periodically cleaned.

For Anti Finger Trap doors, the jamb liner 2832 should be fitted after the frame has been installed onsite.

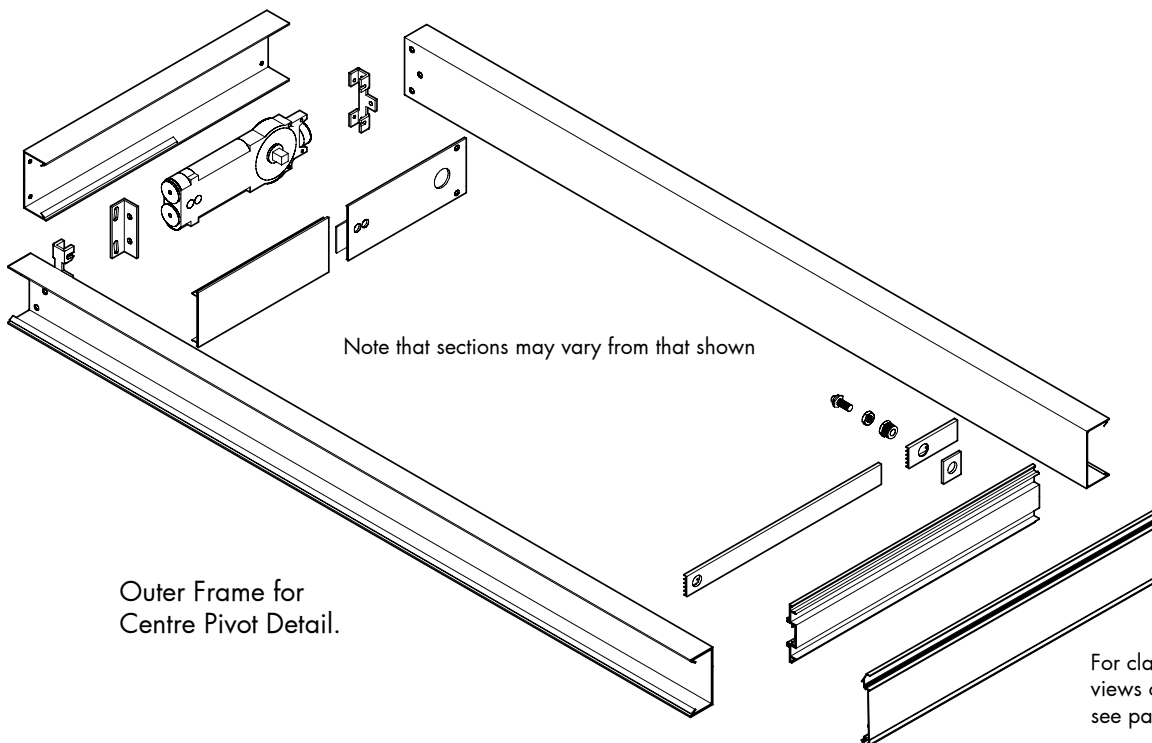

For clarification and pictorial views of grills and there usage see pages 5-14 to 5-18

Assembly Framing

REBATED DOOR

Secure head/transom to door frame with 2 off No 12 x 2" pan head self tapping screws after small gap sealant has been applied to the ends of the head/transom.

On double doors the flushbolts and threshold bolt locate into the threshold by means of a cill flushbolt locator 202/532 or 202/534 and cill flushbolt locator fixing plate 202/534. Slide the fixing plate into the threshold channel then screw the flushbolt locator to the fixing plate with 2 off No 8 x 3/8" pan self tapping screws, but before final tightening of screws, position the locator in the centre of the threshold – then tighten. Note this component is handed and that the hole by the two fixing screws is for the flushbolt in the slave leaf, and the other hole for the threshold bolt in the locking leaf.

On single doors the threshold bolt locates into the pre drilled hole in the threshold grill 202/530 or 202/531. Position the grill into the threshold with the hole at the lock stile end. On double doors this hole is not required and if the grills need to be cut down, then cut from hole end.

The grills may now be placed into the threshold. Note that grills are not fixed into place in order that they can be removed and the threshold periodically cleaned.

Fit pivot hinges 202/528 by positioning the hinge tapping plate into the back of the jamb with the hinge reinforcement 202/38, noting that the spring in the tapping plate can be easily removed if necessary. Screw hinge retaining screws into tapping plate then position outer frame hinge half over hinge retaining screws and tap home locking pin fully into the end of the hinge.

NOTE THAT THE HINGE CANNOT BE REMOVED ONCE FITTED THEREFORE CORRECT ALIGNMENT AND HANDING MUST BE ASCERTAINED BEFORE FITTING.

Slide hinge bush with the locating nub outermost into hinge half, then slide the hinge pin into the hinge bush with the indicator on the top of the pin facing outermost.

Rebate adapters 2820 or 2821 should be fitted after the frame has been installed onsite.

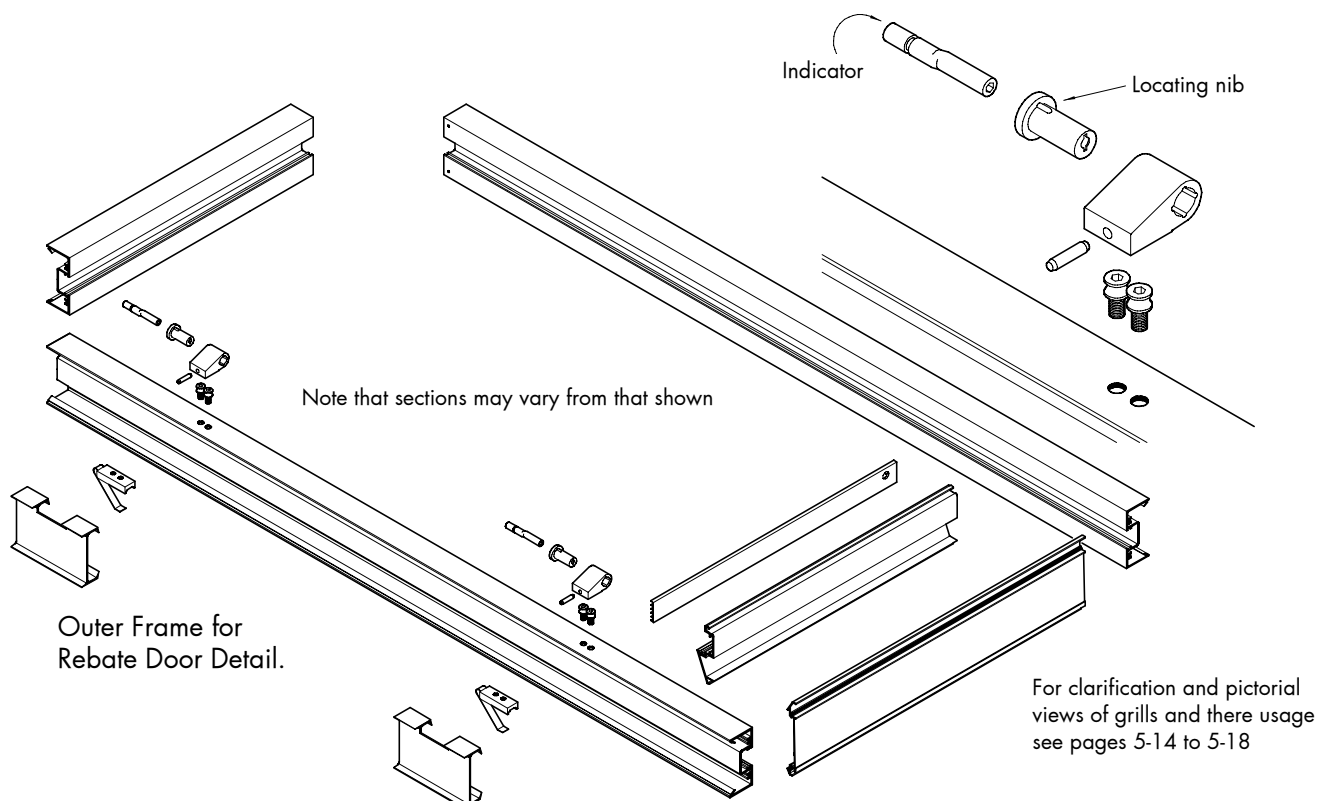

Assembly Framing

REBATE DOOR WITH HEAD CLOSER

Secure transom bracket 202/97 to door frame jambs with 2 off M6 x 12 csk head machine screws and 2 off M6 serrated flange nuts. Apply small gap sealant to ends of head/transom, then screw head or transom to transom bracket with 2 off M6 x 12 csk head machine screws both ends.

Fit Dorma head closer in accordance with instruction leaflet supplied. Then clip in filler plate and secure 202/467 OR 202/468 closer cover plate using two M5 x 35 csk machine screws.

On double doors the flushbolts and threshold bolt locate into the threshold by means of a cill flushbolt locator 202/532 OR 202/533 and cill flushbolt locator fixing plate 202/534. Slide the fixing plate into the threshold channel then screw the flushbolt locator to the fixing plate with 2 off No 8 x 3/8" pan head self tapping screws, but before final tightening of screws, position the locator in the centre of the threshold – then tighten. Note that this component is handed and that the hole by the two fixing screws is for the flushbolt in the slave leaf, and the other hole for the threshold bolt in the locking leaf.

On single doors the threshold bolt locates into the pre drilled hole in the threshold grill 202/530 or 202/531. Position the grill into the threshold with the hole at the lock stile end. On double doors this hole is not required, and if necessary cut down grill from hole end. The grills may now be placed into the threshold. Grills are not fixed into place in order that they can be removed and the threshold periodically cleaned.

Fit pivot hinges 202/528 by positioning the hinge tapping plate into the back of the jamb with the hinge reinforcement 202/38, noting that the spring in the tapping plate can be easily removed if necessary. Screw hinge retaining screws into tapping plate then position outer frame hinge half over hinge retaining screws and tap home locking pin fully into the end of the hinge.

NOTE THAT THE HINGE CANNOT BE REMOVED ONCE FITTED THEREFORE CORRECT ALIGNMENT AND HANDING MUST BE ASCERTAINED BEFORE FITTING.

Slide hinge bush with the locating nub outermost into hinge half, then slide the hinge pin into the hinge bush with the indicator on the top of the pin facing outermost.

Rebate adapters 2820 or 2821 should be fitted after the frame has been installed onsite.

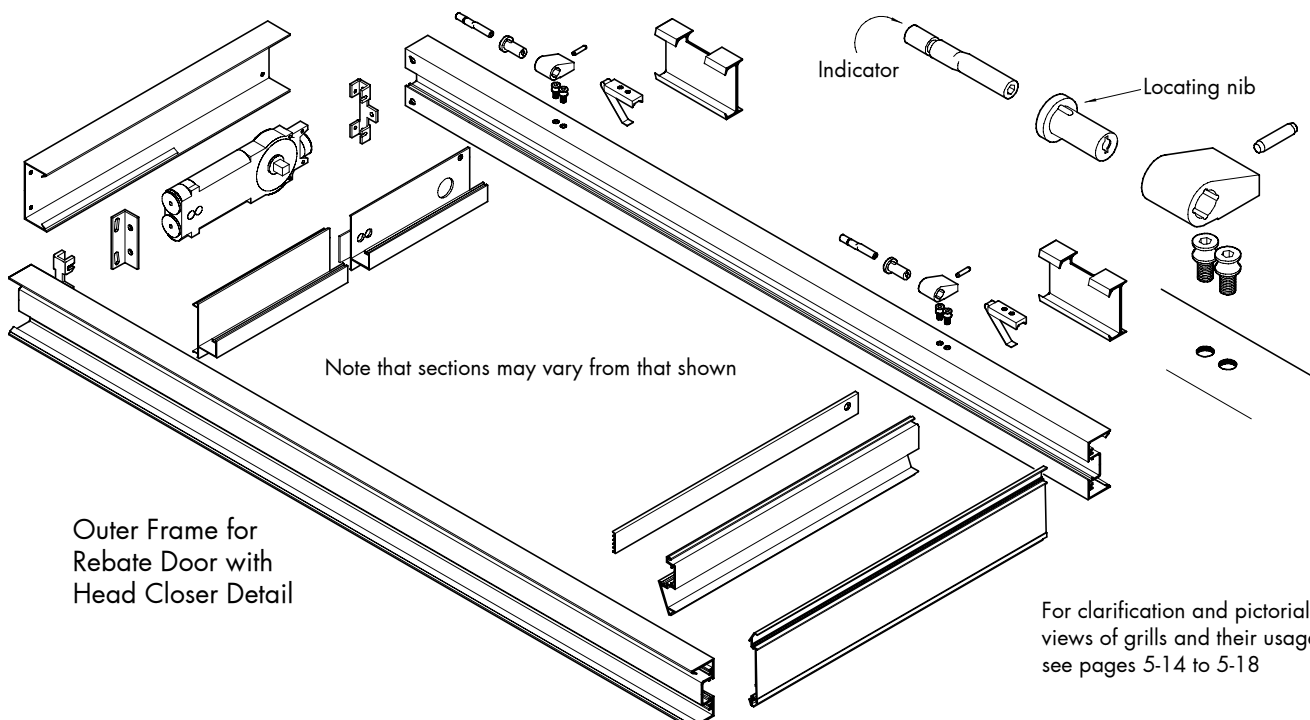

For clarification and pictorial views of grills and their usage see pages 5-14 to 5-18

Assembly

Framing

GENERAL

202/450 end stops must be fitted to both ends of all subcills to avoid water leakage. Before fitting, countersink holes in end stops 8.5 dia for left hand and right hand application. Apply small gap sealant to ends of sub cill 2994, then screw on end stops using No 8 x 3/4" csk head self tapping screws.

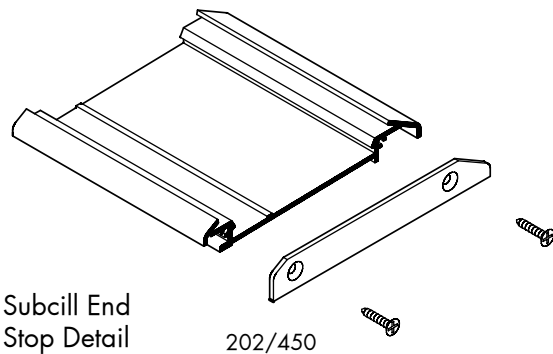

Position the weather bar on the frame, and using the weather bar as a template, mark fixing holes and drill marked positions using 3.0 dia drill. Apply small gap sealant to the back of weather bar and fix to door frame using No 6 x 1/2" pan head self tap screws. Seal on weather bar end caps 202/462 and 202/463. Note that open out rebate door leaves cannot be hung on the frame with the weather bar fitted, and therefore the weather bar must be fitted after the door has been hung.

Weather bar to Head Fixing Detail

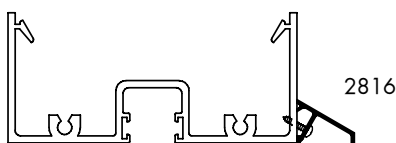

Note that head sections may vary from that shown

EXIT DEVICES (CENTRE PIVOT)

On single doors, position the 202/436 exit device cill locator with the offset hole nearest the inside of the door over the threshold grill and flush at the lock stile end. Using the locator as a template mark fixing hole positions and drill 3.5 dia. Screw locator onto top of grill using 2 No 8 x 1/2" csk head self tap screws. Drill through 12mm hole in locator into grill to allow the bolt to fully engage.

On double doors, fit the 202/421 flushbolt locator as standard, then position the 202/437 exit device cill locator with the offset holes nearest the inside of the door over the flushbolt locator and flush at the ends. Using the locator as a template mark fixing hole positions and drill 3.5 dia. Screw locator down using 2 No 8 x 1/2" csk head self tapping screws. Drill through 12mm holes in locator into flushbolt locator to allow the bolts to locate fully.

Refer to instructions supplied with exit devices for head preparation.

EXIT DEVICES (REBATE DOOR)

On single doors, position the 202/535 exit device cill locator with the offset hole nearest the outside of the door over the threshold grill and flush at the lock stile end. Using the locator as a template mark fixing hole positions and drill 3.5 dia. Screw locator onto top of grill using 2 No 8 x 1/2" csk head self tap screws. Drill through 12mm hole in locator into grill to allow the bolt to fully engage.

Refer to instructions supplied with exit devices for head preparation.

For clarification and pictorial views of threshold grills and locating brackets see pages 5-14 to 5-18

Assembly Framing

GUIDE TO THRESHOLD GRILL ASSEMBLIES

Single Pivot Door L/H Open In-Out.

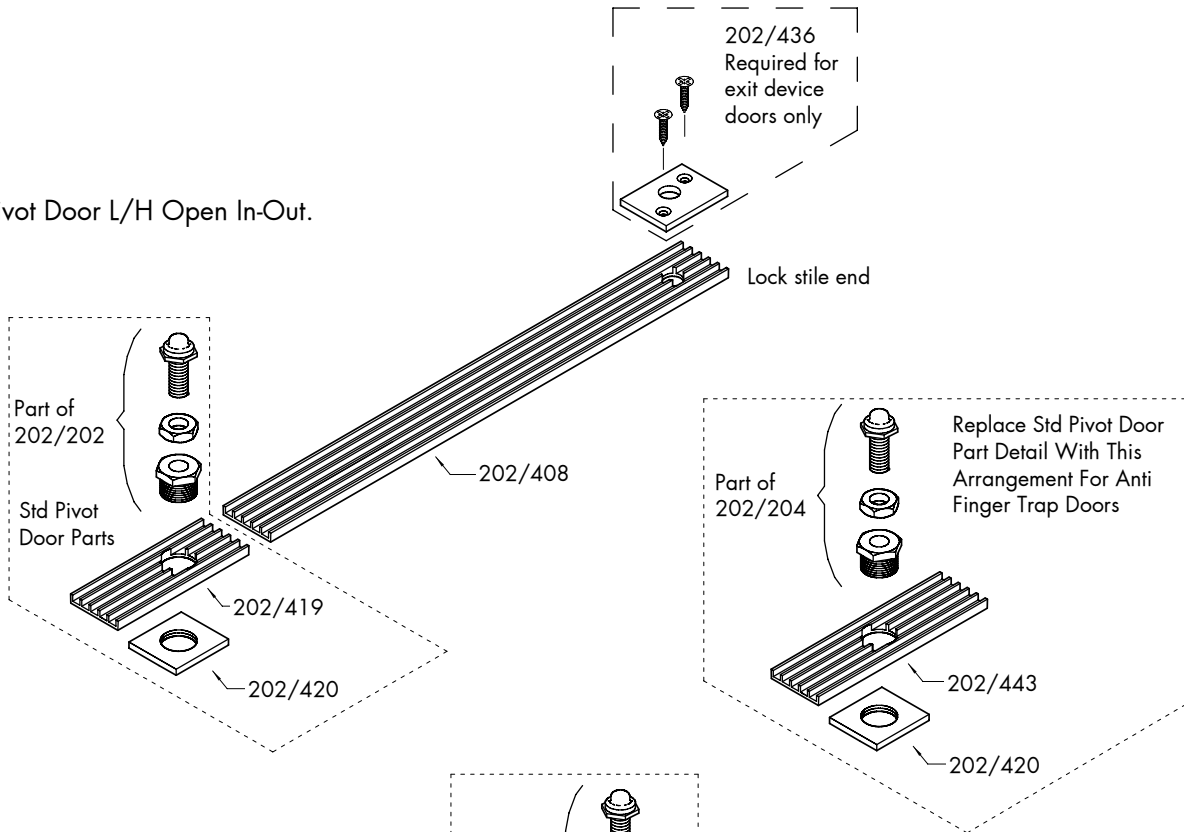

Single Pivot Door R/H Open In-Out.

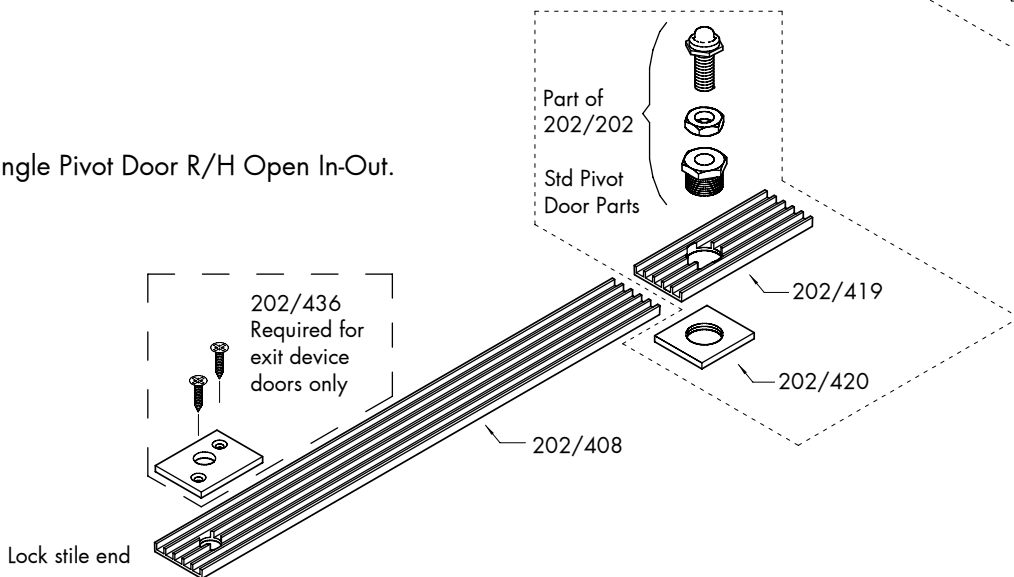

Assembly Framing

GUIDE TO THRESHOLD GRILL ASSEMBLIES

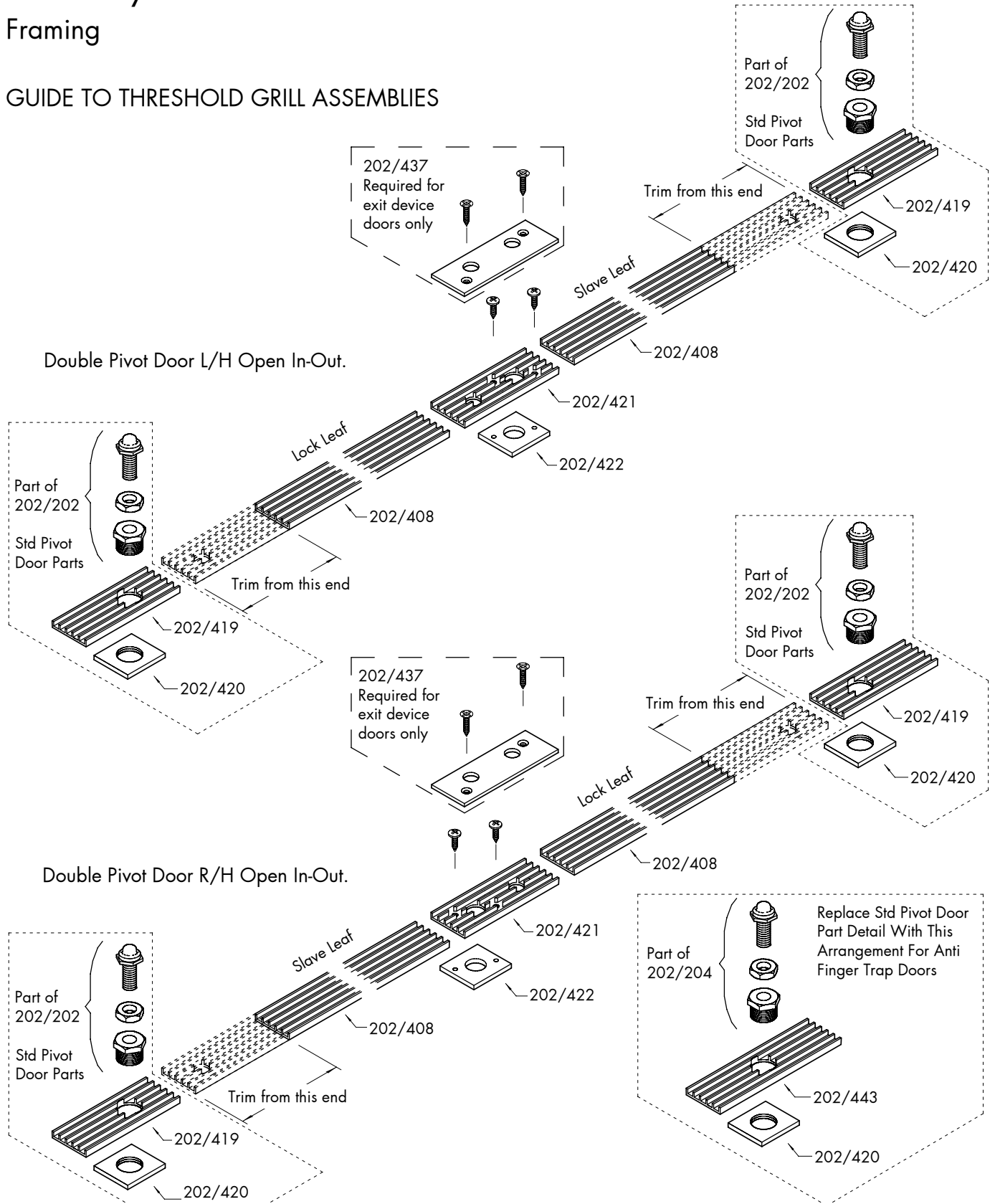

Assembly
Framing

GUIDE TO THRESHOLD GRILL ASSEMBLIES

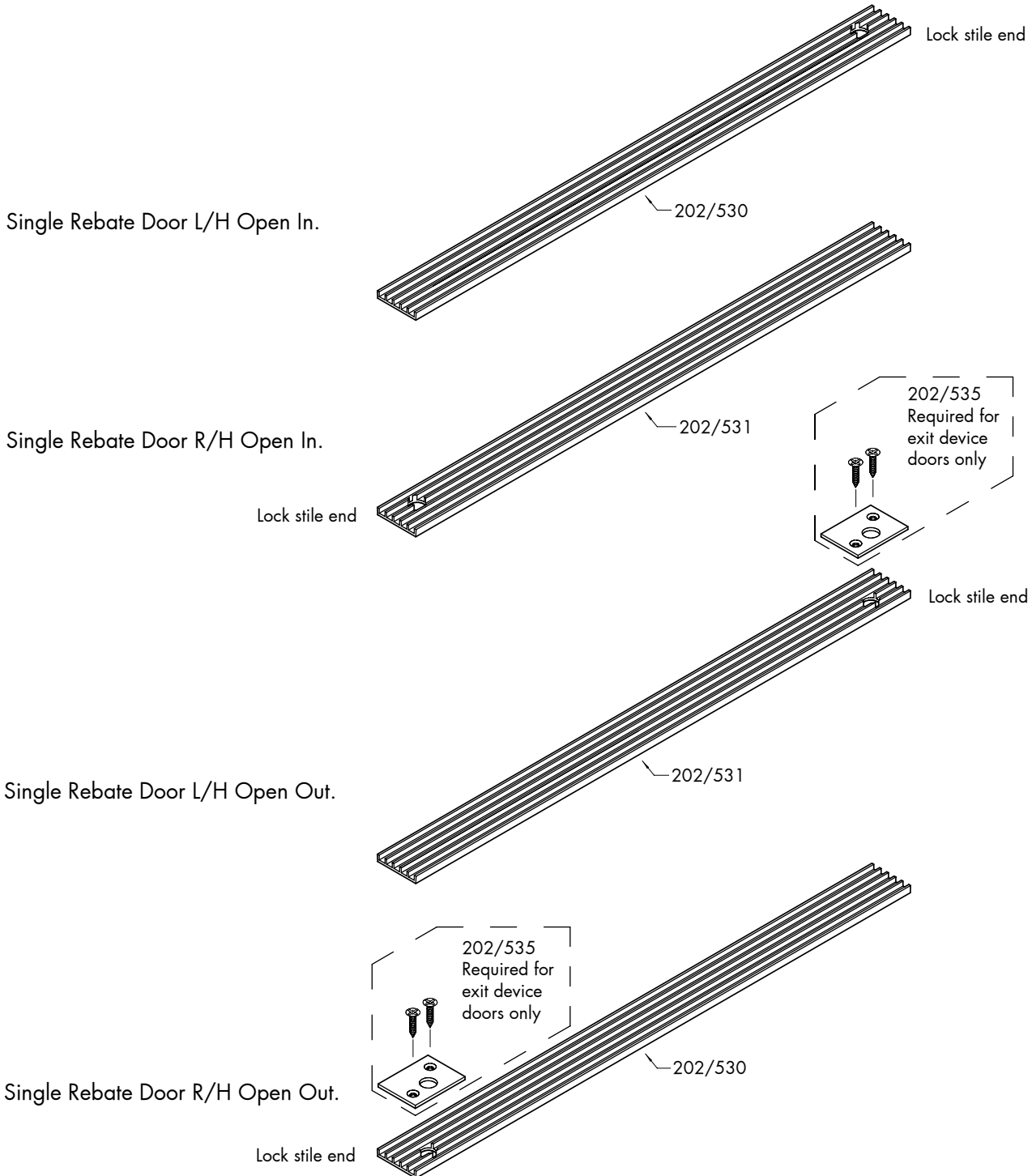

Assembly Framing

GUIDE TO THRESHOLD GRILL ASSEMBLIES

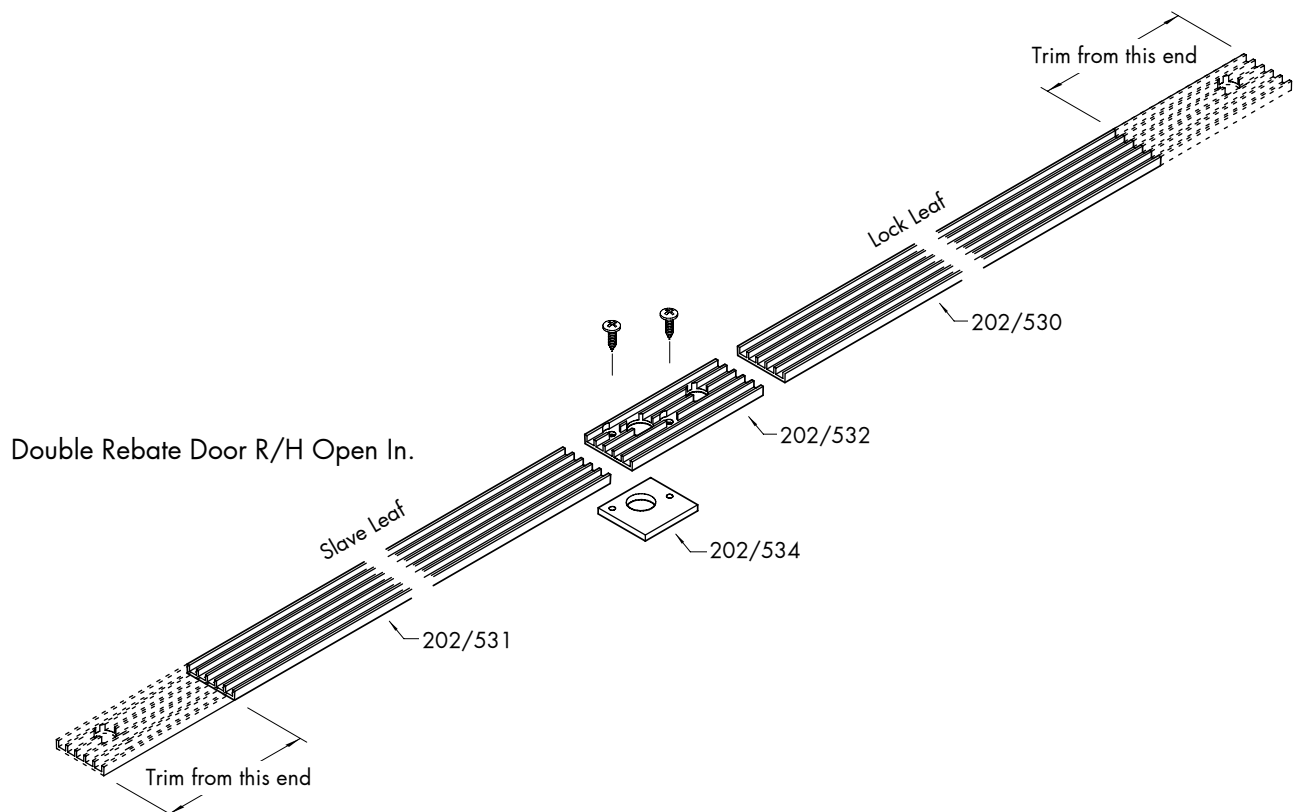
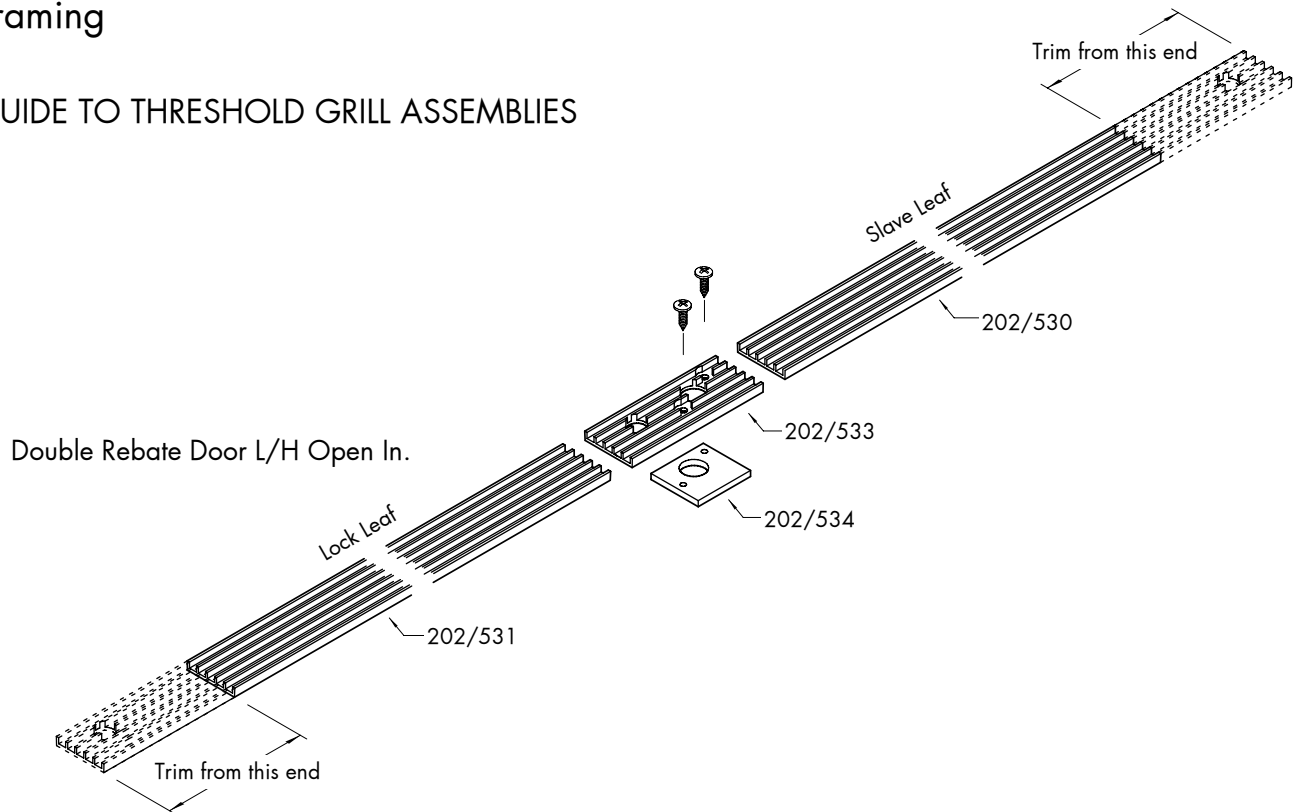

Assembly Framing

GUIDE TO THRESHOLD GRILL ASSEMBLIES

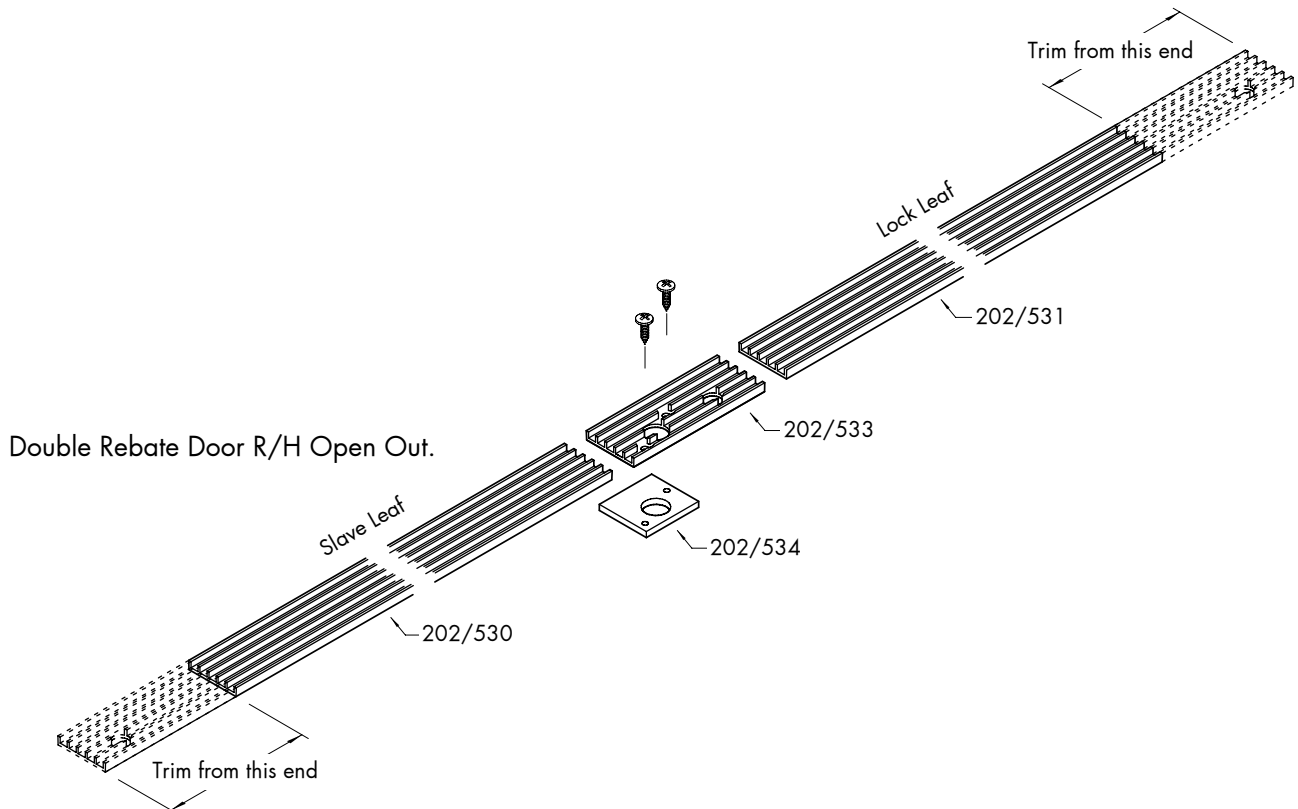
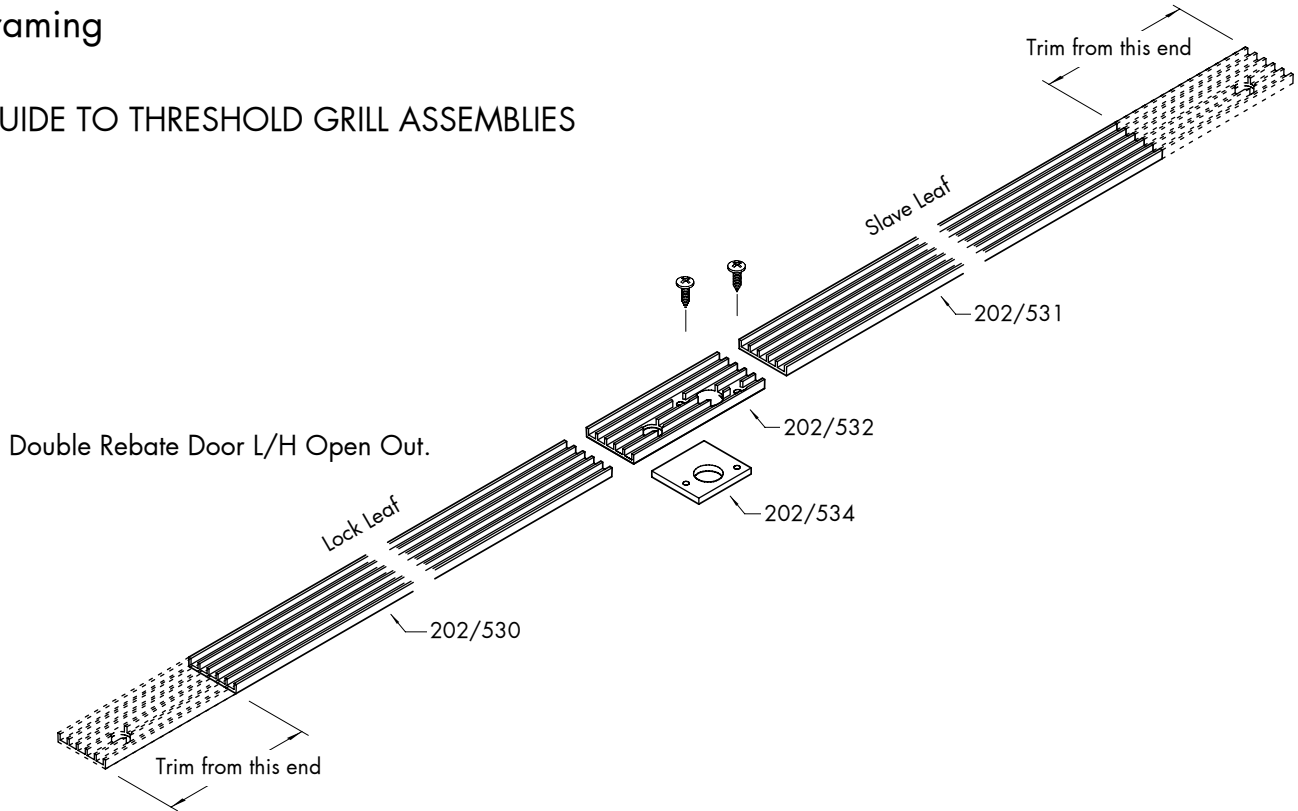

Glazing

General

The 202 High Performance door is bead glazed internally only due to the retainer leg in the profile.

Retaining gaskets 105/91 or 105/140 should be fitted into the outer retainer leg in the profile taking care not to stretch when applying. Trim to length leaving slightly oversize to allow for shrinkage.

Position the bases of corner glazing blocks 202/481 into the corners at positions shown in solid. Place glass in position with an equal gap all round the glass and press home against the outer retained gasket.

Now fit the glazing block wedges and press home so that they hold the glass firmly, but not too tightly in its correct position. Special care must be taken to ensure that the door leaf is not distorted and opens and closes correctly. If the door leaf has dropped then lift the door leaf into the correct position and tighten the glazing block wedges.

Fit inner glazing beads into place applying a spot of small joint sealant at corner joints and bead junctions to form an air seal, cleaning off any surplus sealant. Using the thickest compression wedge gasket (105/87 - /90, /94 and /135) which can be fitted with thumb pressure to tighten up the whole glazing assembly. Commence fitting at the head, jointing or notching at each corner and always taking care not to stretch the gasket, leaving slightly oversize to allow for shrinkage. A roller or similar tool may be used, and lubrication with water is recommended.

NOTE: Glazing is best achieved in situ but if glazing in the factory is required then additional standard resilient locating blocks (not supplied by Glostal) must be fitted at positions shown in hollow to avoid frame distortion during transit and fitting.

Muntin Bar

When glazing beads have been fitted and wedge gaskets are in place, the compression gasket 105/134 should be fed into the clamp plate profile 277. Spacer mouldings 318/25 should be clipped into the muntin bar. The clamp plate should now be fixed to the muntin bar using M5 x 16 csk head machine screws through each fixing hole into spacer moulding. Small joint sealant should be used to seal the joint between the bead and the end of the clamp plate. Clip capping 278 onto the clamp plate.

Glazing Block Positions

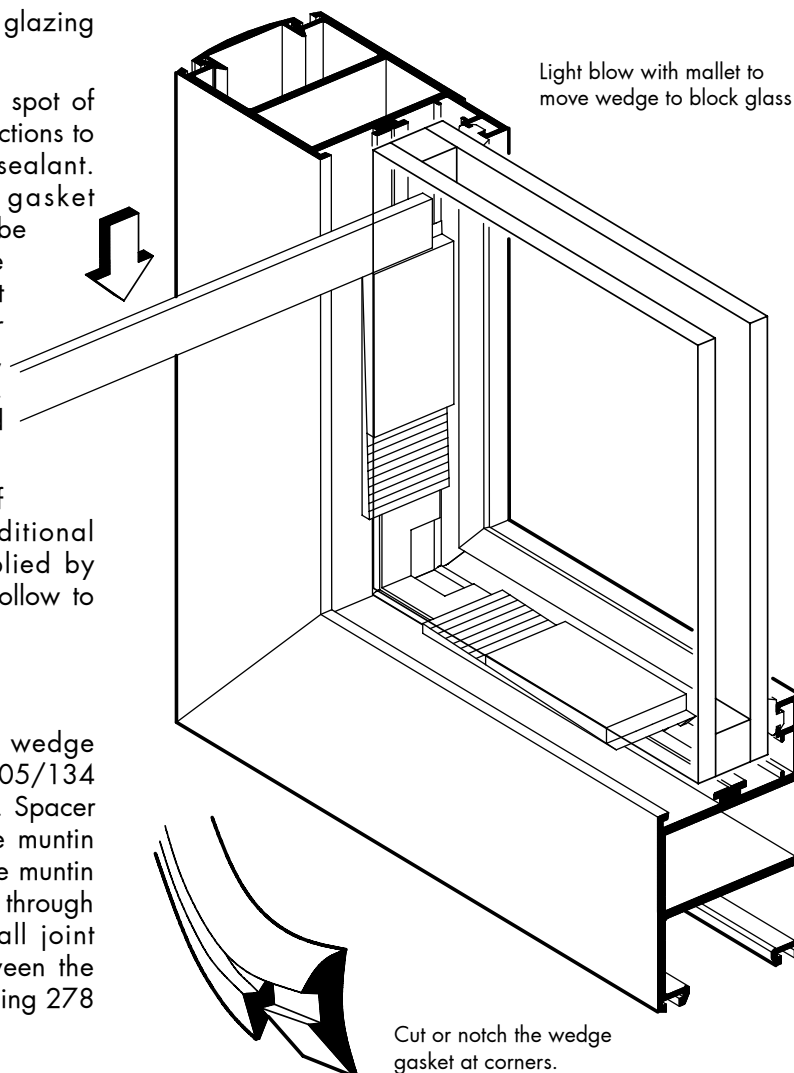
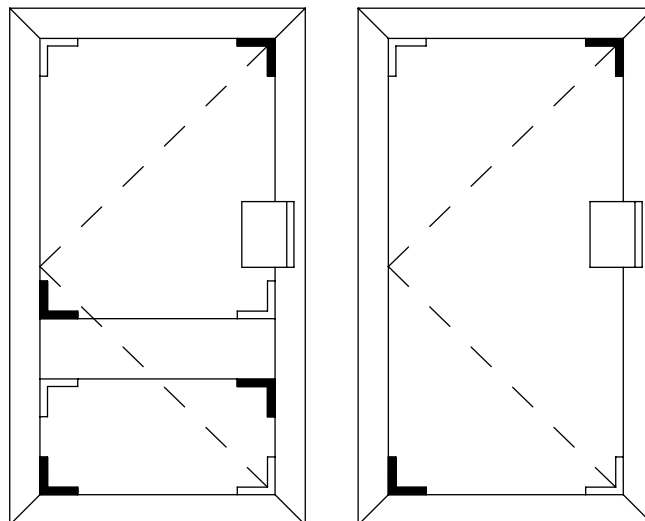

Glazing Gaps

Shown below are the glazing gaps achieved by the range of beads. To arrive at the correct glazing gasket, take the glazing thickness away from the gap, and then take off 3mm or 2mm respectively for the retaining gasket 105/140 or 105/91. The resulting answer is the thickness of glazing wedge required. Shown below are the thicknesses, which each gasket fills when compressed.

NOTE: Due to tolerances in glass and metal, a practical trial should be carried out to ensure correct glazing compression.

24mm glazing only, can be used with muntin bars .
Use gaskets 105/140 and 105/134.

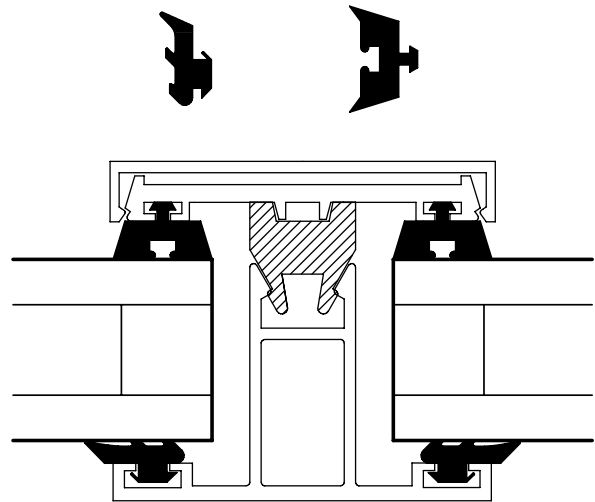

Retained Gaskets

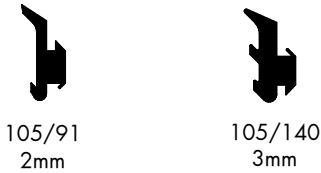

Wedge Gaskets

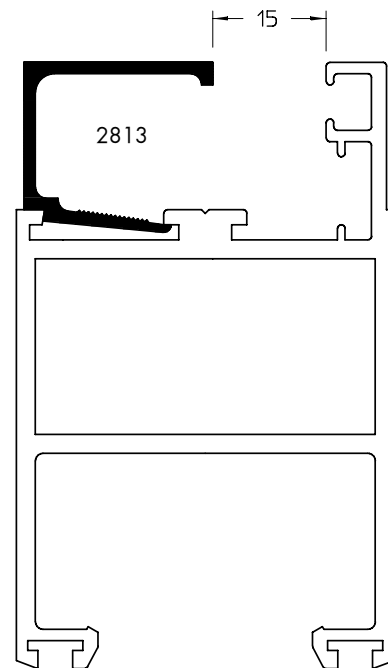
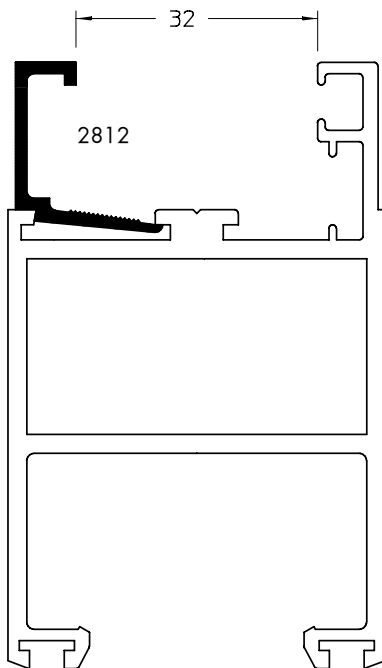
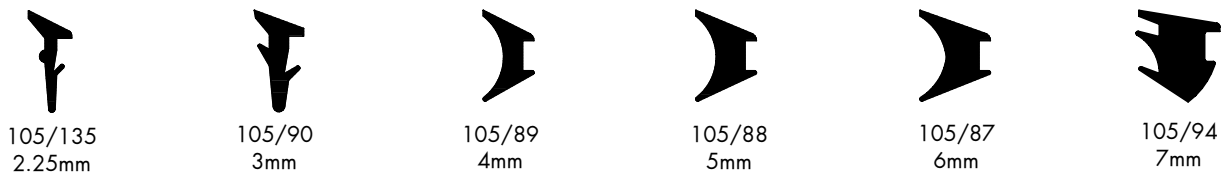

Installation

Framing

The outer frame is installed in exactly the same way as instructed in the 202 Ground Floor Treatments Manual, ie. plumb, square, level and secure.

CENTRE PIVOT

The printed instructions provided with every Dorma door closer must be followed meticulously when hanging the door leaf. If the Dorma instructions and the following points are not observed, Glostal/Dorma will not accept responsibility for failure or cost of replacement. Door leaves are prepared for end load only application in the factory. Particular attention must be given to accurate and secure assembly of closer spindle into closer arm. Special consideration must be given to floor pivot before hanging door leaf. Accuracy of positioning is essential.

If fitting Anti Finger Trap doors, then the jamb liner 2823 must be fitted to the hanging jamb before the door is hung. Fit groove trim 105/75 taking care not to stretch, then trim off flush with the ends of the liner. Fit 202/442 location blocks as shown below (reverse block for 32mm framing) and hold in place with silicone. Offer jamb liner up to jamb and drill through fixing holes into the back of the jamb pocket 4.2mm dia. Seal jamb liner to jamb including cut ends, and fix into place using No 10 x 2" pan head self tap screws.

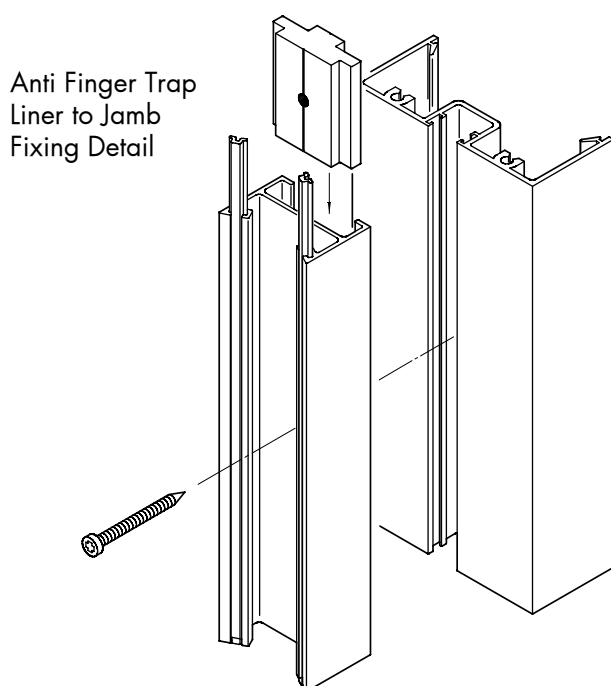

Before proceeding with door hanging, ensure that all door frame accessories are secure. Doors with 202/202 closer arm only, place thrust bearing on pivot with part No facing down. If the closer doesn't have a hold open facility, fully close both regulating valves by turning them clockwise. Use 14mm spanner to rotate spindle to 90° open position, taking care not to damage the machined faces of the closer spindle (Closers without hold open will tend to return very slowly to the closed position, therefore continue immediately with the next operation).

Remove end cap if fitted, then with the door slightly tilted in the 90° position as shown, lift the bottom shoe onto the bottom pivot point ensuring that the bearing fully engages. Tilt the top of the door up onto the closer spindle ensuring that the spindle locates into the top arm. Fit clamping block using two socket cap head screws provided ensuring that screws are tightened evenly and firmly.

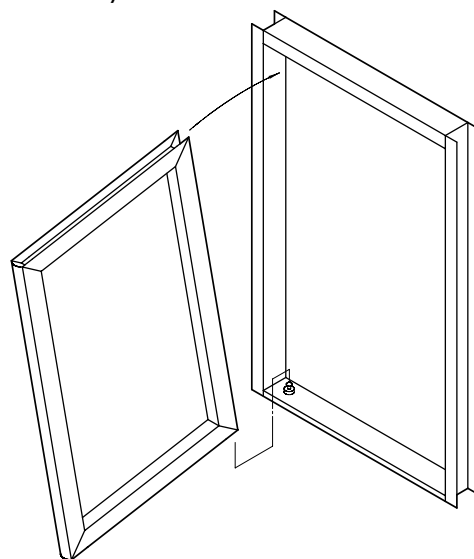

For adjustment of door alignment, slacken socket cap head screw in top of closer arm. Head of door may be moved towards hang jamb or vice versa by turning the adjustment screw in the closer arm located at closer spindle end (std doors) or at lock stile end (Anti Finger). After adjustment ensure that adjustment screw bears firmly against end of closer arm, and secure socket cap screw in top of closer arm. The bottom of the door can be adjusted by removing the grill and unscrewing the bottom pivot, then sliding the bottom pivot sideways. Retighten pivot and adjust grill length to suit. After final adjustment, clip in end cap.

Installation

Framing

CENTRE PIVOT (cont)

Neutral position is regulated by two hex head bolts at the top of the closer arm, which should be locked tightly into position. If necessary, one bolt may be omitted to obtain maximum adjustment in which case the remaining screw is securely tightened to hold the arm against the opposite flange.

For adjustment of closing speed start with latch valves open (anti clockwise). Adjust latch valve (furthest from spindle) by opening door 20° and allowing it to close.

(clockwise = slower, anti clockwise = faster).

Adjust sweep valve (nearest to spindle) by opening 90° and allowing it to close.

(clockwise = slower, anti clockwise = faster).

If the door closer fails to operate correctly it is possible that the closer arm has been incorrectly assembled to the closer spindle. Check security of closer arm clamping piece and register of closer spindle with closer arm. If there is any doubt, remove door and repeat assembly procedure.

As indicated in the Specification – Size Limitations, door closers are available in different spring strengths. Site conditions can dictate the strength required i.e. if door opens too easily after valve adjustment, fit stronger spring unit.

Closer arm
202/202

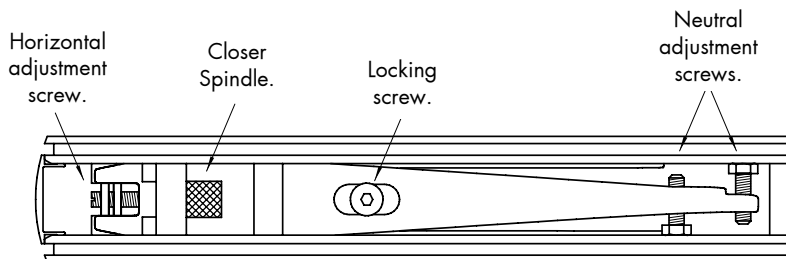

Closer arm
202/204

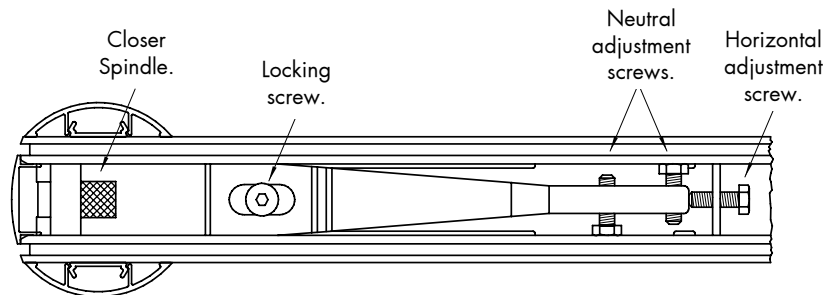

Head
Closer

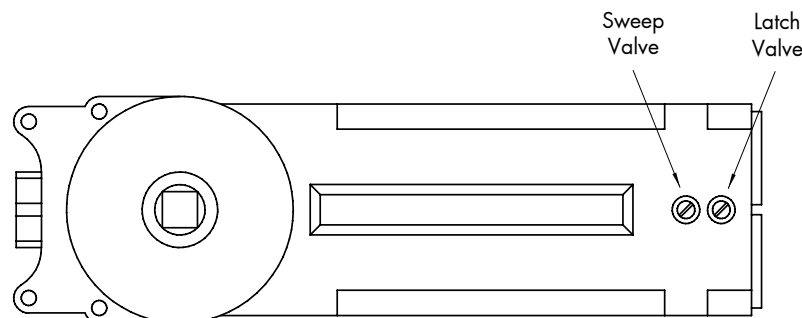

REBATE DOORS

Pivot hinge door leaves are assembled in the workshop for "lift on" fitting on site. Note that the frame weather bar on open out doors must be fitted after door installation as the door cannot be hung with the weather bar fitted unless the door can be opened 180°.

After installation of the outer frame, and threshold has been clipped into the sub cill, fix in the jamb and then the head rebate adaptors (2820 or 2821) with No. 8 3/8" pan head self tapping screws 50mm from the ends and at centres of 400mm (note that head rebate adaptors are not required for rebate doors with head closers). Fit bulb seal, starting at the head and run continuously round to butt joint at the head, taking care at all times not to stretch.

Lower door leaf onto hinges and check for operation and alignment. The door alignment can be adjusted in two ways, by rotation of the hinge bush or rotation of the hinge pin or a combination of both the hinge bush and pin. Neutral position is as shown with the pin indicator and the bush locating nib facing away from the door. Initial adjustment can be obtained by inserting a 5mm Allen key into the end of the hinge pin and rotating in the desired direction. If further adjustment is required then the hinge bush can be rotated by removing from the hinge body and rotating 90° and reinserting into the hinge. Again final adjustment can be achieved by rotating the hinge pin. Once final adjustment has been made, insert the grub screw supplied with the hinge into the back of the door leaf hinge half and tighten in place in order to maintain correct door alignment.

For rebate doors with head closer, after the door leaf has been hung open door leaf to 60° and position the closer arm over the slide guide and locate (if required remove the guide screw in the arm, align then refit the guide screw). Check for action and adjust closing speed if required.

For adjustment of closing speed start with latch valves open (anti clockwise). Adjust latch valve (furthest from spindle) by opening door 20° and allowing it to close.

(clockwise = slower, anti clockwise = faster).

Adjust sweep valve (nearest to spindle) by opening 90° and allowing it to close.

(clockwise = slower, anti clockwise = faster).

If the door closer fails to operate correctly it is possible that the closer arm has been incorrectly assembled to the closer spindle. Check security of closer arm clamping piece and register of closer spindle with closer arm.

As indicated in the Specification – Size Limitations, door closers are available in different spring strengths. Site conditions can dictate the strength required i.e. if door opens too easily after valve adjustment, fit stronger spring unit.

